



Performances in Stockyard Technologies

SCHADE
AUMUNDGROUP

CONTENT

4	Longitudinal Stockyards Stacker
6	Bridge-Type Scraper Reclaimer
8	Portal Scraper Reclaimer
10	Multiple Purpose Portal Bridge Reclaimer
11	Combined Stacker / Scraper Reclaimer
12	Semi-Portal Scraper Reclaimer
13	Cantilever Scraper Reclaimer
14	Circular Stockyards
15	Circular Storage with Stacker and Cantilever Reclaimer
16	Circular Storage with Stacker and Bridge-Type Scraper Reclaimer
18	Buffer Storages of Longitudinal Shape
19	Buffer Storages of Circular Shape
20	Blending Beds of Longitudinal Shape
21	Blending Bed of Circular Shape
22	Integrated systems
24	After Sales Service and Retrofits
26	AUMUND Group

SCHADE Lagertechnik GmbH

SCHADE ranks among the world-leading suppliers of bulk material stockyards and blending bed technology for all major industries. As a member of the AUMUND Group with subsidiaries and affiliates in England, France, Poland, Switzerland, Brazil, India, China and the USA, SCHADE enjoys the benefits of a global network combined with a large product range.

Expertise. Since the foundation in 1879, SCHADE became a recognised leader in the field of stockyard equipment. Throughout the years, SCHADE's efforts have been concentrated on developing, sustaining and enhancing technological achievements. As pioneers in the stacker / reclaimer market, SCHADE has a long and distinguished reputation for innovative engineering and superior quality.

Backed by decades of experience, with more than 600 references throughout the world, SCHADE provides stockyard equipment of customised design and leading edge stacker / reclaimer technology. SCHADE's expertise is best demonstrated by the outstanding service life of stockyard equipment worldwide operating under severe conditions.

Excellence in conception and the ability to perceive the best-suited technical solutions for the individual project and the customers' needs are distinct characteristics of SCHADE engineers. The highly motivated team with its profound process technology knowledge in all industries is made up of skilled mechanical and electrical engineers committed to making each contract a successful performance.

Project specific design and engineering combined with solid construction, extremely low wear, easy and cost-effective operation guarantee the performance expected by operators and investors alike.

Global Competence. The strategic alliance with AUMUND is the tool providing immediate access to the global distribution and After Sales Service network of a strong Group, a large portfolio and development of new concepts. The Group's global resources, providing established engineering expertise and craftsmanship, domestic market knowledge, local procurement, manufacture and project coordination, enhance SCHADE's quality service from the early planning and layout stages through to the final engineering, manufacture, installation and start-up as the competent partner for all stockyard applications.

Our Philosophy. To meet the challenge of combining traditional values of more than 50 years in business with an innovative approach to meet today's expectations of customers on all five continents.

Close customer relation, excellent service, superior product quality and the objective to remain in the forefront of stacker / reclaimer development are an expression of our commitment to support innovations, identify needs and provide cost-effective and tailor-made solutions of leading edge technology, while preserving our principal goal to serve the interests of our customers from the early project phase through years of trouble-free operation.



AUMUND Headquarters, central workshop and logistic center in Rheinberg, Germany

SCHADE excellence in storing, blending and reclaiming all kinds of bulk materials

In all major industries

Metallurgy & Mining Industry

- Coal, Coking Coal
- Limestone
- Iron Ore
- Bauxite

Cement Industry

- Limestone, Clay, Marl, Alluvium
- Coal
- Petcoke
- Gypsum
- Slag
- Additives

Power Industry

- Coal
- Lignite
- FGD-Gypsum
- Limestone
- Biomass
- Wood Pellets

Chemical Industry

- Fertiliser
- Potash
- Phosphates
- Salt
- Sulphur

Ports & Terminals

- All kinds of bulk materials

With an extensive range of products and services

Products

- Stockyards and Blending Systems
- Stackers
- Tripper Cars
- Bridge-Type Scraper Reclaimer
- Portal and Semi-Portal Scraper Reclaimer
- Cantilever Reclaimer
- Combined Stacker / Reclaimer
- Circular Storages with Bridge-Type Reclaimer
- Circular Storages with Cantilever Reclaimer
- Integrated Systems of Materials Handling and Storing

Services

- Planning
- Consulting
- Engineering
- Field Assembly
- Supervisor Services
- Commissioning
- After Sales Service
- Provision of Spare Parts
- Refurbishments
- Plant Upgrading
- Training

Specialisation

- Equipment designed to suit bulk materials with abrasive properties, high humidity, frozen or compacted

As well as the Pulp & Paper, Agricultural and other Industries



Fig. 1 Slewing/Luffing/Stacker for 2,750 t/h Coal

Longitudinal Stockyards

Depending on the stacking method defined by the type of stockyard, buffer or blending bed, stacking in open stockyards of longitudinal shape is performed with stackers equipped with a travelling and luffing or luffing and slewing mechanism. Feeding of the stacker itself is carried out by a belt conveyor with tripper car.



Stacker

SCHADE stackers are equipped with different counterweight arrangements and the luffing mechanism of the stacker is driven either by a hydraulic drive unit (fig. 1) or a winch (fig. 2). The PLC of the stacker is programmed to control the preset stacking method.

The Chevron and Cone Shell stacking methods require a travelling and luffing stacker (fig. 3), while the Strata stacking method needs a luffing and slewing stacker.

The Strata stacking method is a SCHADE development to allow homogenisation of coal of various types and origins. With the Strata stacking method, the stockpile is built up in inclined layers. The stacker builds the first layer travelling along the storage area with its boom at a low elevation. The stacker then moves towards the stockyard centre in pre-set steps while gradually lifting the boom. The result are superimposed inclined layers, matching the angle of repose of the bulk material and



Fig. 2 Slewing/Luffing Stacker for 1,000 t/h Coal



Fig. 3 Luffing Stacker for 2,000 t/h Limestone



Fig. 4 Stacker with by-pass system

providing a good blending degree as the scraper reclaimer cuts into each of the many layers. Covered stockyards in A-frame buildings require a tripper car (fig. 5) installed in a structure suspended from the building roof. The travel of the tripper car is PLC controlled and programmed to build either a Cone Shell or a Chevron stockpile, depending on the type of reclaimer, i.e. bridge-type, portal or cantilever and the desired rate of homogenisation.

If various bulk materials have to be stacked into two or more compartments within a storage building, the SCHADE product range offers a shuttle conveyor with reverse travel ensuring distribution of the material with the desired stacking method.



Fig. 5 Travelling tripper carriage



Bridge Scraper Reclaimer, 50 m span, 1,100 t/h, Coal

Bridge-Type Scraper Reclaimer

The maximum blending effect is no doubt achieved with the bridge-type scraper reclaimer combined with the relevant stacking method. SCHADE's first bridge-type scraper reclaimer was installed in 1975 to homogenize and reclaim 350 t/h abrasive limestone. The scraper chain on this machine had a lifetime of 5 years with 24-hour continuous operation. A special design is a 50 m span bridge-type reclaimer for 1,125 t/h coal installed in a German power plant. Apart from the fact that the scraper chain of this reclaimer had a life-span of 15 years, this bridge-type reclaimer has the particularity of serving two parallel blending beds. With its bogies of special design allowing 90° rotation, the reclaimer can be moved between the piles on rails arranged at right angles at the end of the stockyard without the use of a transfer carriage. Further examples are a 56 m span bridge-type reclaimer for homogenizing

limestone with a reclaim capacity of 1,200 t/h or a blending bed with a 2,000 t/h reclaim capacity in a coal mine in South Africa. Recent applications reach up to 60 m rail span and reclaim capacities of more than 2,200 t/h.

Material discharge onto the collecting conveyor is made either over a concrete ramp arranged alongside the whole length of the blending bed or an inclined drag trough. The inclined drag trough, forming an integrated part of the scraper bridge, located at the scraper chain's discharge end, travels with the machine while loading the reclaimed material onto the belt conveyor.

As with all SCHADE reclaimers, the scraper chain is designed and manufactured to SCHADE standards, going beyond the technical characteristics of present



Bridge Scraper Reclaimer, 26.4 m span, 250 t/h, Limestone



Bridge Scraper Reclaimer, 27.5 m span, 300 t/h, Gypsum



Bridge Scraper Reclaimer, 56 m span, 1.200 t/h, Limestone



Bridge Scraper Reclaimer, 35 m span, 500 t/h, Iron Ore

chain standards and achieving outstanding operating hours. SCHADE scraper chains are also fitted with automatic tensioning ensuring equal take-up of both chain strands.

In addition to the SCHADE scraper chain, SCHADE bridge-type scraper reclaimers feature a full facing harrow, i.e. the harrow covers the total cross-section of the stockpile. This large harrow, compared with the commonly used small-sized harrows which only cover a small cross-section of the stockpile, has the distinctive benefit of ensuring perfect homogenisation and a constant and homogeneous material flow onto the reclaiming belt conveyor. Whereas small harrows need a long stroke to cover the total cross section, the SCHADE harrow only needs one short stroke, i.e. a short travel distance, hence guaranteeing substantially reduced wear.

Portal Scraper Reclaimer

Larger stockyards with a span exceeding 30 m are operated with a portal scraper reclaimer. As early as 1978, SCHADE engineers designed and built a portal scraper reclaimer for an open cast coal mine in South Africa with a span of 50.5 m to reclaim 2,125 t/h coal, which at that time was the worldwide largest portal scraper reclaimer ever built. This outstanding performance was soon followed by a portal scraper reclaimer to reclaim 1,000 t/h limestone in an USA cement plant and a further portal scraper reclaimer with a span of 50 m for a cement plant in Canada.

Developments during the following years resulted in ever larger machines, such as two portal scraper reclaimers installed at a coal mine in Australia to reclaim 3,100 t/h coal with a span of 52 m and a portal scraper reclaimer of innovative design commissioned in 2000 in a power plant in Germany.

This special-design reclaimer allows 2,400 t/h lignite to be reclaimed with just one scraper boom: A world record. Today, SCHADE engineers are building portal scraper reclaimers for stockyards of 63 m with a reclaim capacity of 4,000 t/h and machines with a span of more than 70 m are soon to come.

As a standard, SCHADE portal scraper reclaimers for large span stockpiles, whether for indoor or outdoor operation, are fitted with a boom guide to withstand horizontal forces and avoid unstable movements of the free end of the scraper boom. The boom guide was first introduced and patented by SCHADE. The portal structure, as a further standard, is designed and built as a torsion-free welded frame.

For operation in A-frame buildings, scraping is performed by two scraper booms forming one unit. The hinged link of particular design connecting both booms in the centre ensures that the discharging end of the additional boom is always in a higher position than the top of the main scraper boom. This typical SCHADE design guarantees perfect discharge conditions while eliminating the risk of boom collision.



Portal Scraper Reclaimer, 32 m span, 400 t/h, FGD-Gypsum



Portal Scraper Reclaimer, 49 m span, 550 t/h, additives



Portal Scraper Reclaimer with twin booms,
52 m span, 3,100 t/h, Coal



Portal Scraper Reclaimer, 33 m span, 600 t/h, Slag



Portal Bridge Reclaimer, 50 m span, 600 t/h, Coal



Portal Bridge Reclaimer, 50 m span, 1,225 m³/h for combined storage and blending of various coal qualities

Multiple Purpose Portal Bridge Reclaimer

An outstandingly versatile design, developed by SCHADE, is the portal bridge reclaimer which, contrary to the conventional bridge-type reclaimer, has the distinctive advantage of reclaiming and blending several stockpiles of various bulk materials arranged in line. This multiple purpose blending bed system is served by just one single reclaimer, a major asset when discussing investment costs and simple operating conditions. The multi-purpose portal bridge reclaimer combines the benefits of the bridge-type and the portal scraper reclaimer.

Travelling on two rails (1) alongside the stock, just as the conventional bridge reclaimer, this machine features a portal structure (3) reaching high enough to clear the pile and a horizontal scraper boom (4). The horizontal scraper boom carries a roller-mounted sledge (5) moving back and forth driven by a rope winch (6). Being connected to the lower end of the harrow (7), the sledge drags the same along the horizontal scraper boom. The upper end of the harrow is mounted on rollers fitted to the top of the triangular jib (8). The same rollers guide the harrow cables and control the cable tension through a counterweight (9) supported by both trolleys (2). The jib's inclination matches the bulk material's natural angle of repose. The back and forth movement of the sledge drags the harrow like a wiper across the pile slope. The material trickling down is captured by the chain (10) of the horizontal scraper boom to be transferred in a steady flow to the reclaiming conveyor arranged alongside the stockpile.

The high blending effect is achieved by the constant movement of the harrow across the entire section of the stockpile. To change from one pile to the other, the scraper boom is lifted above the piles with its sledge and scraper chain, hence allowing it to travel along

the stockpiles. A further asset is the ability to lift the scraper boom into an inclined position, thus allowing it to attack the pile side like a normal portal reclaimer with inclined scraper boom. This additional feature of the portal bridge reclaimer has the benefit of ensuring not only homogenisation but also making sure it can reclaim frozen stockpiles, pile areas representing a fire hazard or reclaim from compartments.

Example demonstrating the possibility of servicing several bulk material stockpiles with only one portal bridge scraper reclaimer as alternative for the bridge-type scraper reclaimer which is operating between two piles only.

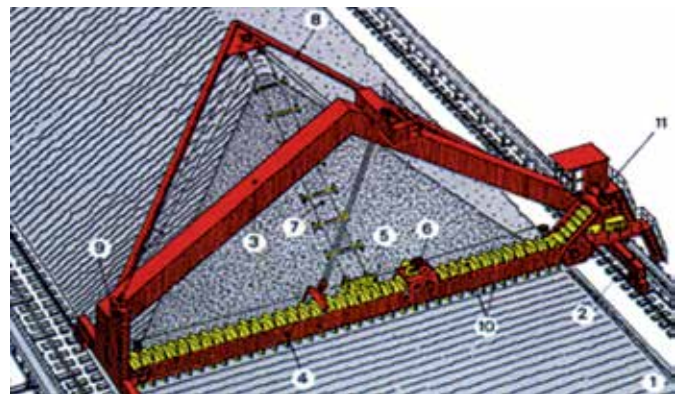

Portal Bridge Reclaimer components

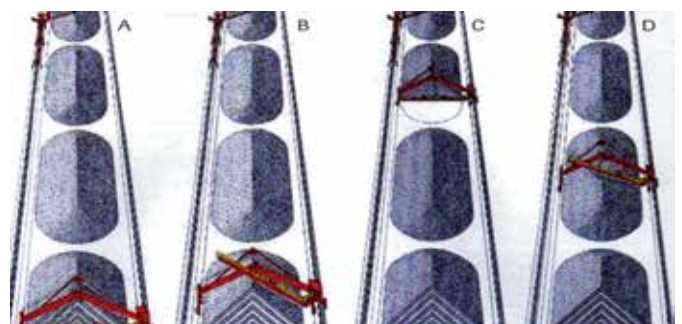



Combined Stacker Reclaimer, 46 m span, stacking 600t/h, reclaiming 300t/h, Coal

Combined Stacker / Scraper Reclaimer



Combined Stacker Reclaimer, 47 m span, stacking 1,500 t/h, reclaiming 900 t/h, Coking Coal

The combined stacker / scraper reclaimer introduced in 1973 for installation in a coking plant in Germany was developed and patented by SCHADE. As with many applications, reclaiming and stockpiling do not need to be carried out simultaneously; both functions can be combined in one single machine forming a compact unit. The system comprises a portal structure travelling on rails. The portal structure accommodates the scraper boom as well as the stacking unit; a design that minimises the overall structure weight. For rectangular stockyards requiring simultaneous stacking and reclaiming, separate machines are required.



Semi-Portal Scraper Reclaimer, 21 m span, 150 t/h, additives

Semi-Portal Scraper Reclaimer

For indoor operation, the best ratio between the building section and the stockpile section is, in most cases, achieved with a semi-portal scraper reclaimer. The height of the retaining wall inside the building is defined to provide full use of the available storage area. Semi-portal scraper reclaimers are the ideal solution for stockyards with limited space or stockyards divided into compartments.

All SCHADE portal scraper reclaimers are equipped with scraper chains manufactured to SCHADE standards, going beyond the technical characteristics of present chain standards. The SCHADE chain with a proven track record of wear resistance achieves outstanding operating hours. Keeping in mind low maintenance and operating costs, the scraper chain is fitted with automatic chain tensioning ensuring equal take-up of both chain strands.



Semi-Portal Scraper Reclaimer, 14 m span, 80 t/h, FGD-Gypsum



Direct discharge on belt conveyor



Cantilever Scraper Reclaimer designed for frozen Coal

Cantilever Scraper Reclaimer



Cantilever Scraper Reclaimer, boom length 18 m, 200t/h, additives



Discharge via impact idler table

The cantilever scraper reclaimer travels on a track arranged along one side of the stockpile and features a boom with double-strand chain and scraper blades. If used in combination with the Strata stacking method, a SCHADE invention, a certain degree of homogenisation of the stored material can be obtained. Even nowadays, the cantilever scraper reclaimer remains the most economical solution for small open-air stockyards up to 30 m span and has the distinctive advantage of being a flexible, light-weight machine.

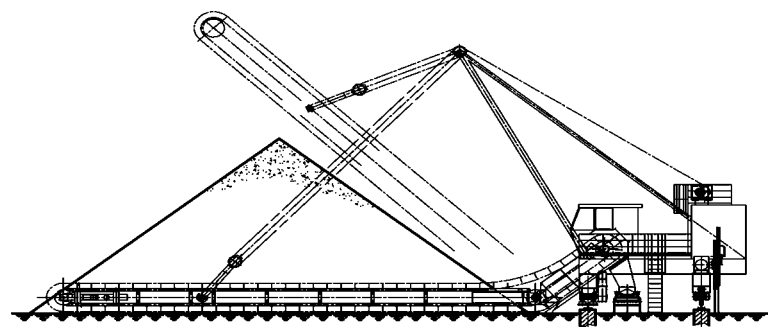

Cantilever Scraper Reclaimer with drag trough



Circular Stacker Cantilever Scraper Reclaimer, dia 120 m, stacking 4,000, reclaiming 2,000 t/h, Coal

Circular Stockyards

An achievement born out of the need for systems requiring less space for large storage quantities is the circular stacker / reclaimer, a prominent SCHADE domain. Depending on the application and the desired results, the circular stacker / reclaimer is either built with a cantilever reclaimer, a portal or a bridge-type reclaimer. While the cantilever scraper reclaimer is used for buffer storage, the circular stacker with bridge-type reclaimer is meant for storage and homogenisation.

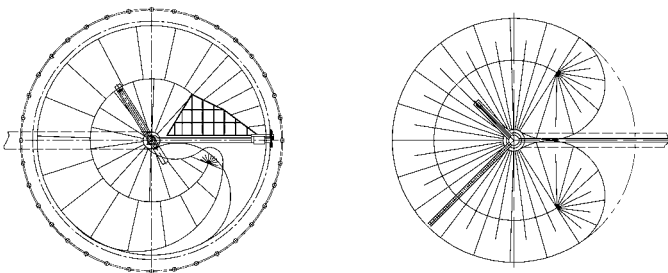

Cantilever Scraper Reclaimer, dia 120 m, stacking 2,500, reclaiming 250 t/h, Salt



Circular Stacker / Cantilever Scraper Reclaimer, dia 70 m, stacking 1,000 t/h, reclaiming 100 t/h, Slag



Circular Stacker / Cantilever Scraper Reclaimer, dia 61 m, stacking 1,700 t/h, reclaiming 2,500 t/h, Iron Ore concentrate



Circular Stacker / Semiportal Scraper Reclaimer, dia 120 m, stacking 3,000 t/h, reclaiming 1,500 t/h, Coal

Circular Storage with Stacker and Cantilever Reclaimer

Feeding of the stockyard is generally made with a slewing stacker receiving the material from a fixed belt conveyor. The slewing stacker deposits the material in the Cone Shell method. Whenever a pile has reached the preset height, the stacker advances one step, turning around its centre. The stockpile is built up in a simple automatic manner. Reclaiming is made from the inner slope with the cantilever scraper reclaimer mainly comprising the scraper boom supporting the double-strand scraper chain and the wear-proof shovels. The scraper boom advances in a circular movement scraping the inner slope of the pile. Whenever it has described the preset slewing range, the boom is lowered by a preset step determining the cutting depth. The reclaimed material is guided into the central discharge chute leading to the reclaiming conveyor.

The cantilever stacker / reclaimer allows for simultaneous stacking and reclaiming and both functions operate totally independently which guarantees a high degree of flexibility. All stacking and reclaiming steps are PLC controlled for fully automatic operation.

Stacker / reclaimer for open circular stockyards were first installed by SCHADE in the late sixties for the chemical industry, in the late seventies for limestone storage in cement plants in India, followed in the early eighties by woodchip storage in the USA.

With stringent environmental regulations and the increasing demand for protecting the stored material, enclosed storages became more and more popular.

The first stacker / reclaimer in a covered circular stockyard was designed and built by SCHADE in 1988 for stacking, storing and reclaiming 95,000 m³ coal in a storage of 97 m diameter. The SCHADE giants include 10 circular stockyards operating in a harbour in Taiwan. The storage buildings of these units commissioned between 1997 and 2002 have a diameter of 120 m and the equipment reaches a stacking capacity of 4,000 t/h and a reclaim capacity of 2,000 t/h. Each unit allows storage of 180,000 t. Depending on the application, circular storages are also built with portal or semi-portal scraper reclaimers.

Circular Storage with Stacker and Bridge-Type Scraper Reclaimer

If homogenisation of the stored bulk material is required, a bridge-type scraper reclaimer replaces the cantilever scraper reclaimer.

Circular stockpiles with bridge-type scraper reclaimer for homogenisation require a stockpile built up as a blending bed. To achieve this, a slewing and luffing stacker is needed to pile the material according to the Chevcon method. The slewing and luffing stacker located inside the storage building receives the material from a belt conveyor supported by a large anti-friction bearing on the central structure. The slewing / luffing stacker is supported on the welded tube of the centre column.

The bridge-type reclaimer, collecting the material from the front of the pile, incorporates a heavy radial bridge as a carrying structure connected to the centre column and the head girder

with its bogies travelling on the circular track around the stockpile. The harrow mounted onto the bridge covers the pile's cross section and moves slowly to and fro across the face of the stockpile.

Below the bridge and in parallel with the base and the face of the stockpile, the scraper chain conveys the material radial to the central hopper located below the centre column.

All movements of the equipment are programmed in compliance with the specific needs of the plant, PLC controlled and designed for fully automatic operation, whether operating on open stockpiles or inside roofed structures.



Circular Stacker / Bridge Scraper Reclaimer, rail dia 104 m, stacking 1,200 t/h, reclaiming 1,200 t/h, Coal



Circular Bridge Stacker / Bridge Scraper Reclaimer, rail dia 78 m, stacking 1,000 t/h, reclaiming 300 t/h, Limestone



Circular Stacker / Bridge Scraper Reclaimer, rail dia 120 m, stacking 2,500 t/h, reclaiming 1,600 t/h, Coal

Typical Applications of SCHADE Equipment

Buffer Storages of Longitudinal Shape

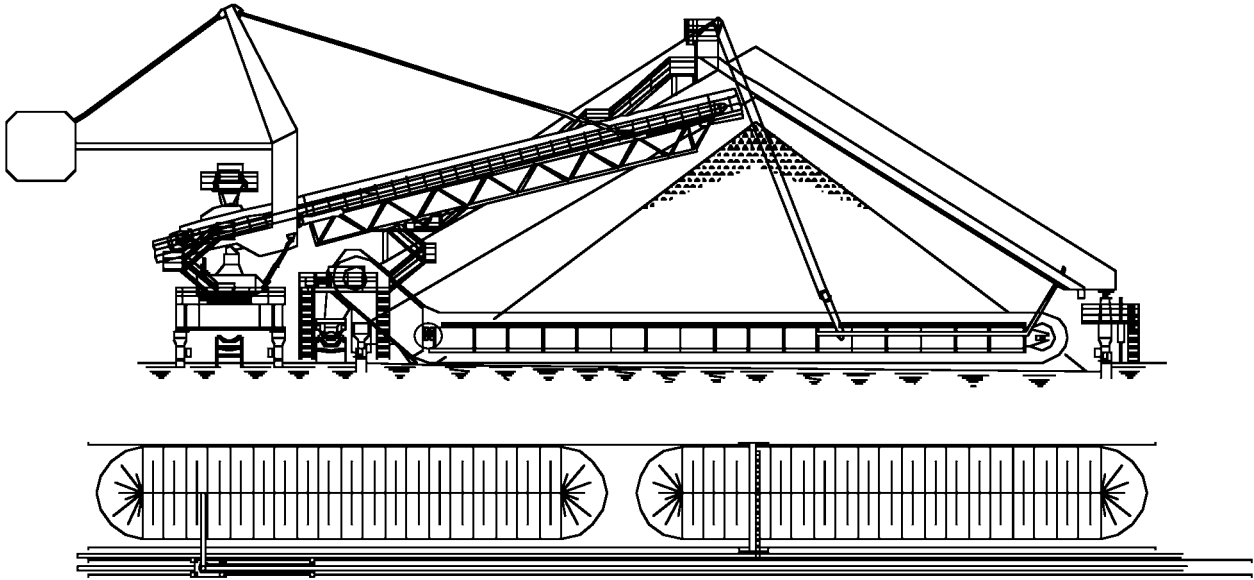

Outdoor operation with stacker and scraper reclaimer

- Stockpile built up by a travelling and luffing / slewing stacker
- Reclaim made from the slope side either with a cantilever scraper reclaimer for pile widths up to 30 m or a portal scraper reclaimer for pile widths exceeding 30 m
- Operating along the whole length of the stockpile or preselected sections of the stockpile
- Automatic operation
- Quick travelling between different working locations

Outdoor operation with combined stacker / reclaimer

- For applications where stacking and reclaiming do not need to be carried out simultaneously
- Stacking and reclaiming performed with one machine only
- Less space required
- Reduced capital expenditure

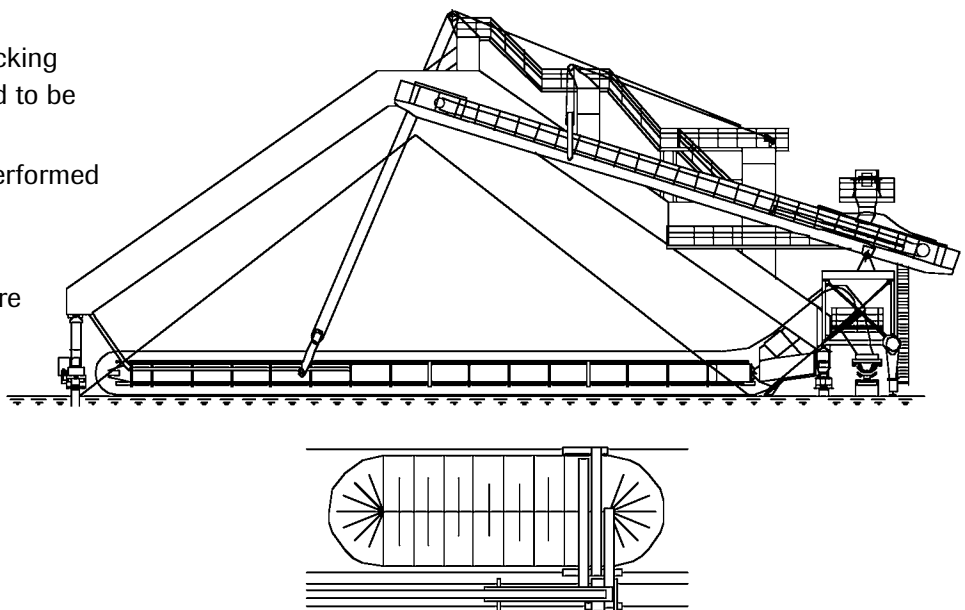

Operation in enclosed buildings with tripper car and portal or semi-portal scraper reclaimer

- Stockpile built up by a tripper car
- Free-sloping or comparted by walls
- Reclaim made from the slope side with a portal or semi-portal scraper reclaimer
- Automatic operation
- Operating along the whole length of the stockpile or compartments
- Quick travelling between different working locations
- Reduced building height with portal scraper reclaimer due to special arrangement with 2 booms

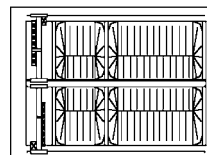
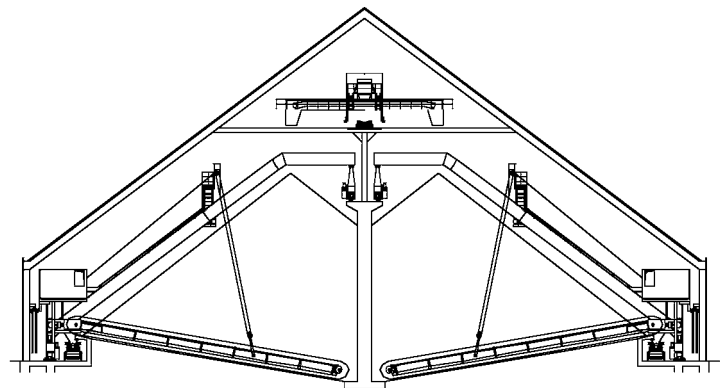
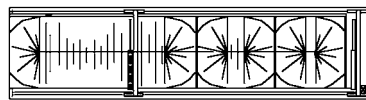
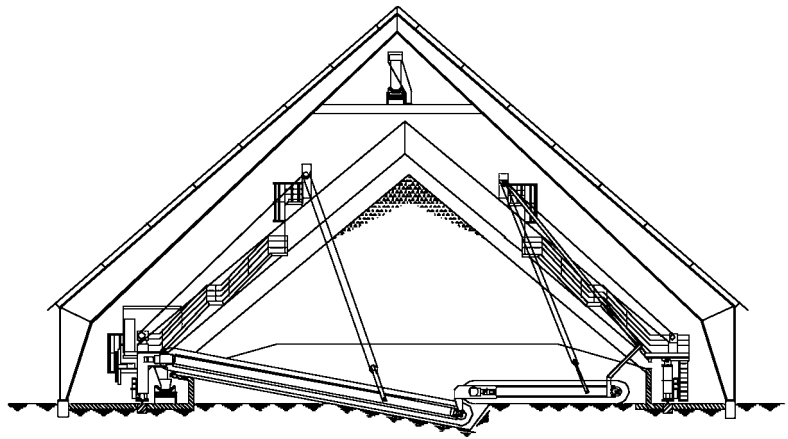

Buffer Storage of Circular Shape

Indoor operation with stacker and cantilever scraper reclaimer

- Less space required than with storages of longitudinal shape
- Large storage capacities on small surface
- Stockpile built up by the slewing stacker
- Reclaim made from the inner slope with the cantilever scraper reclaimer
- Automatic operation

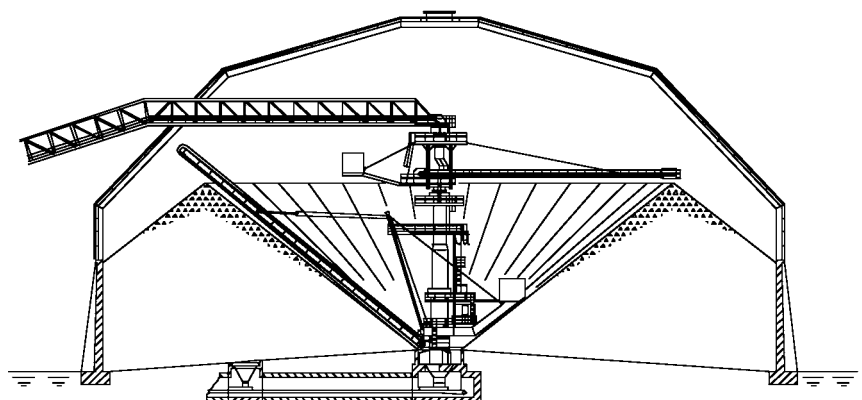

Typical Applications of SCHADE Equipment

Blending Beds of Longitudinal Shape

Operation with stacker or tripper car and bridge-type scraper reclaimer

- Stockpile built up by a travelling and luffing stacker or tripper car in the Chevron method
- Reclaim made from the front of the pile with bridge-type scraper reclaimer
- Perfect homogenisation and blending of segregated material
- Automatic operation
- Simultaneous stacking and reclaiming with two piles and bridge-type reclaimer with two harrows

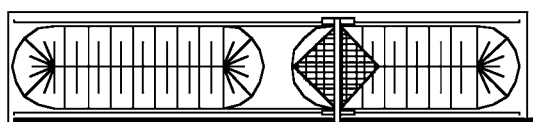
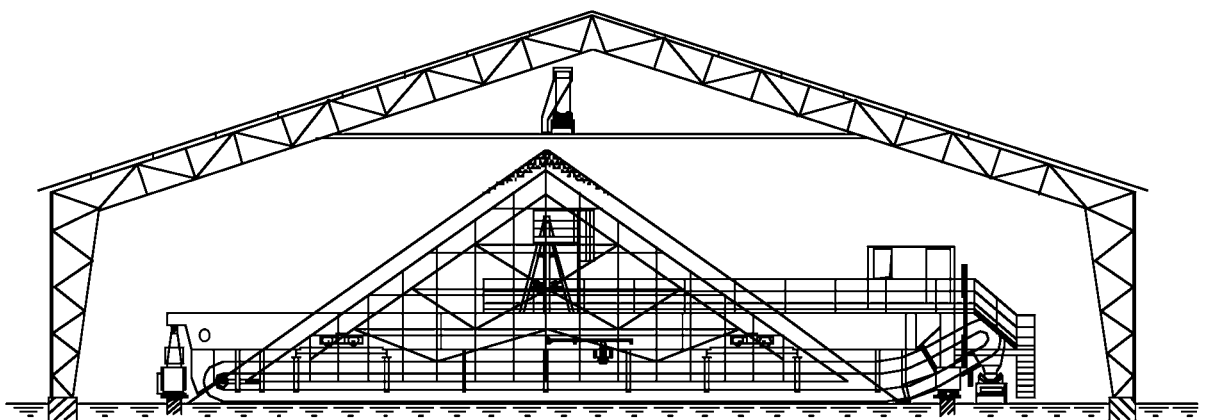
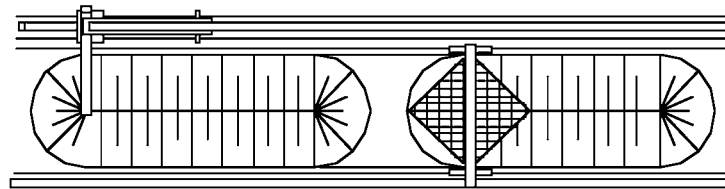
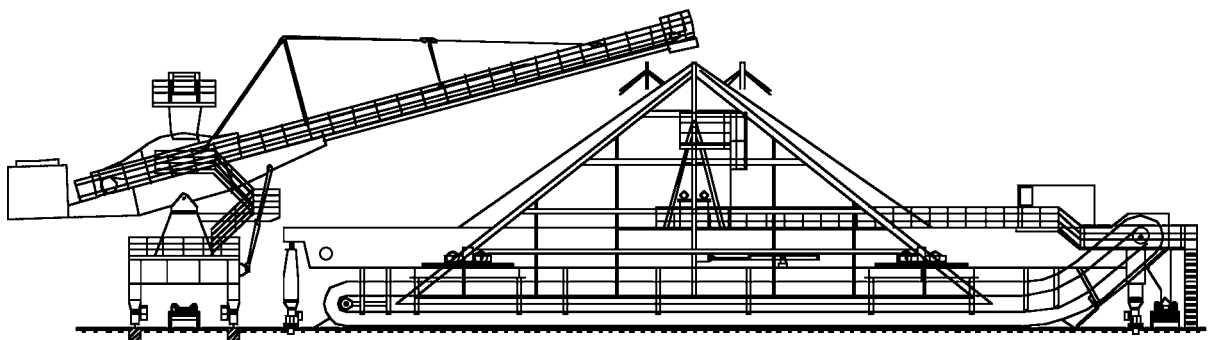

Blending Beds of Circular Shape

Operation with stacker or tripper car and bridge-type scraper reclaimer

- One pile built up continuously in the Chevron method (Chevcon)
- With a slewing and luffing stacker
- Bridge-type scraper reclaimer with one harrow
- 360° rotation and endless pile
- Excellent blending
- In enclosed buildings or outdoor operation

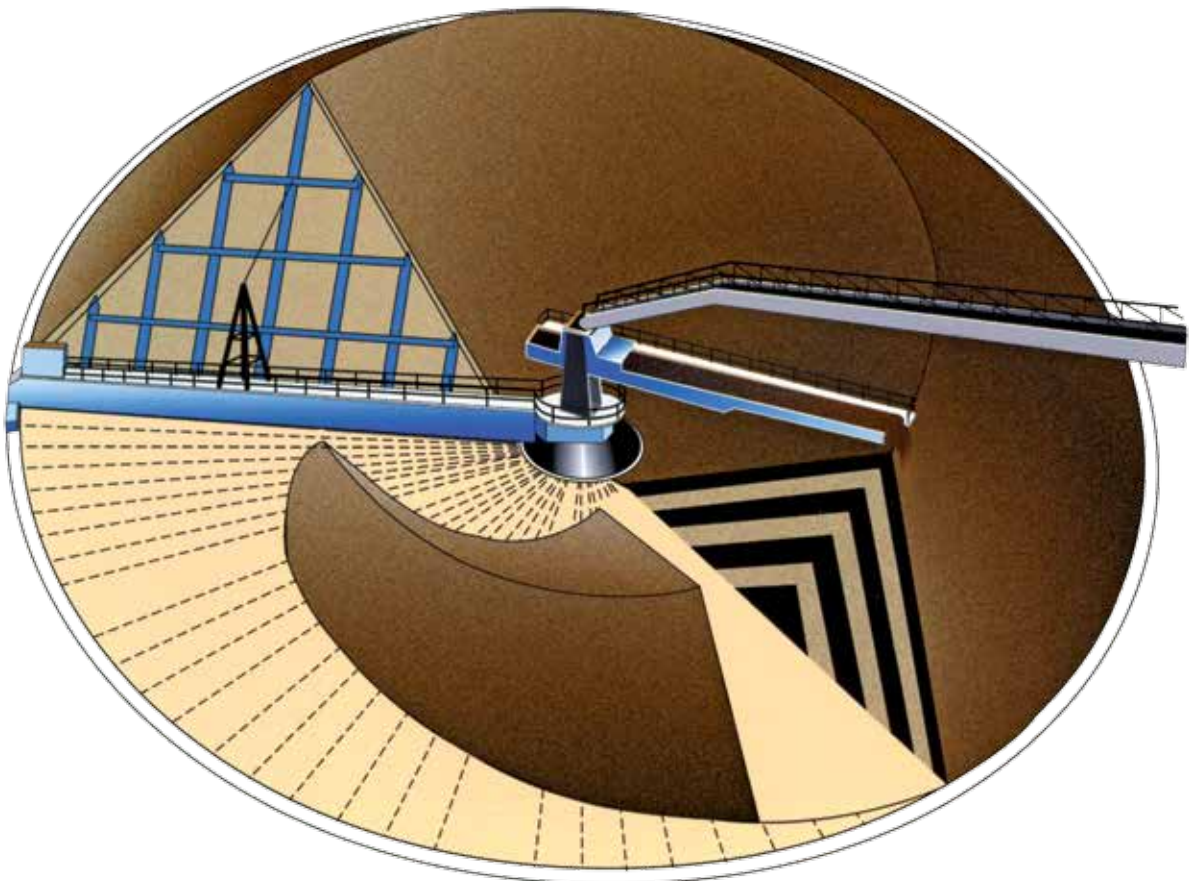
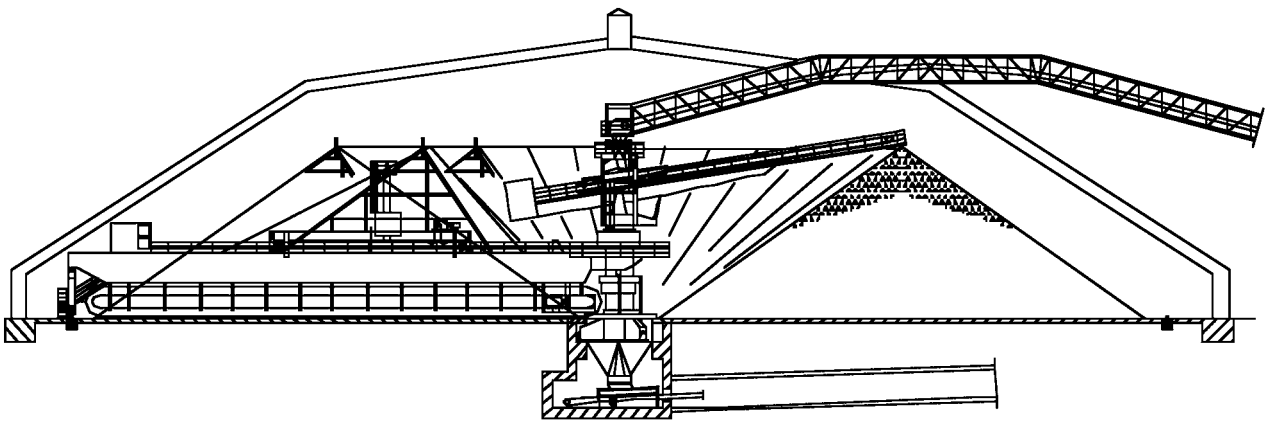

Integrated Systems

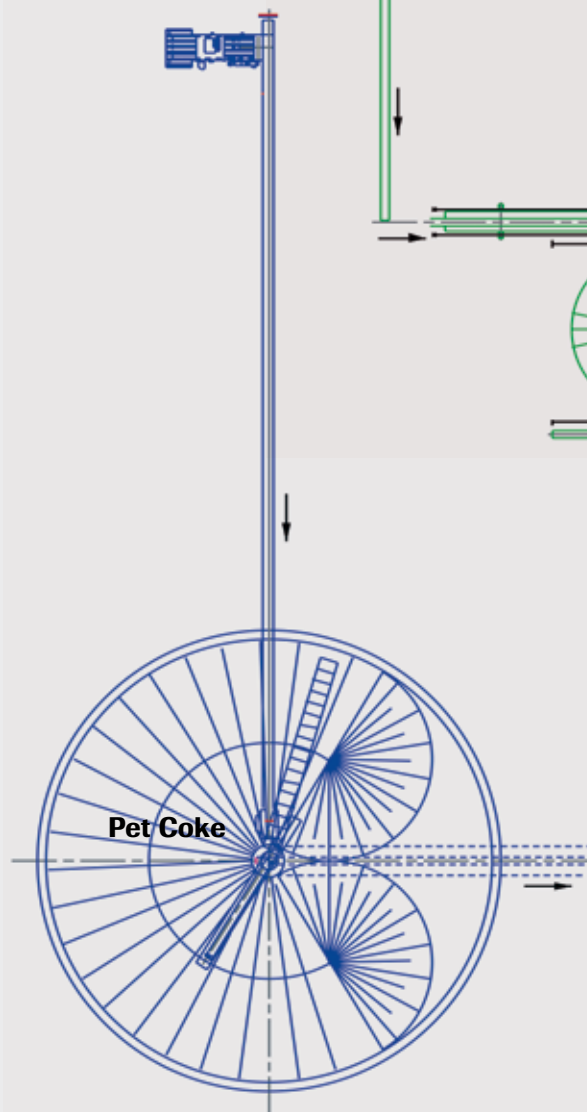
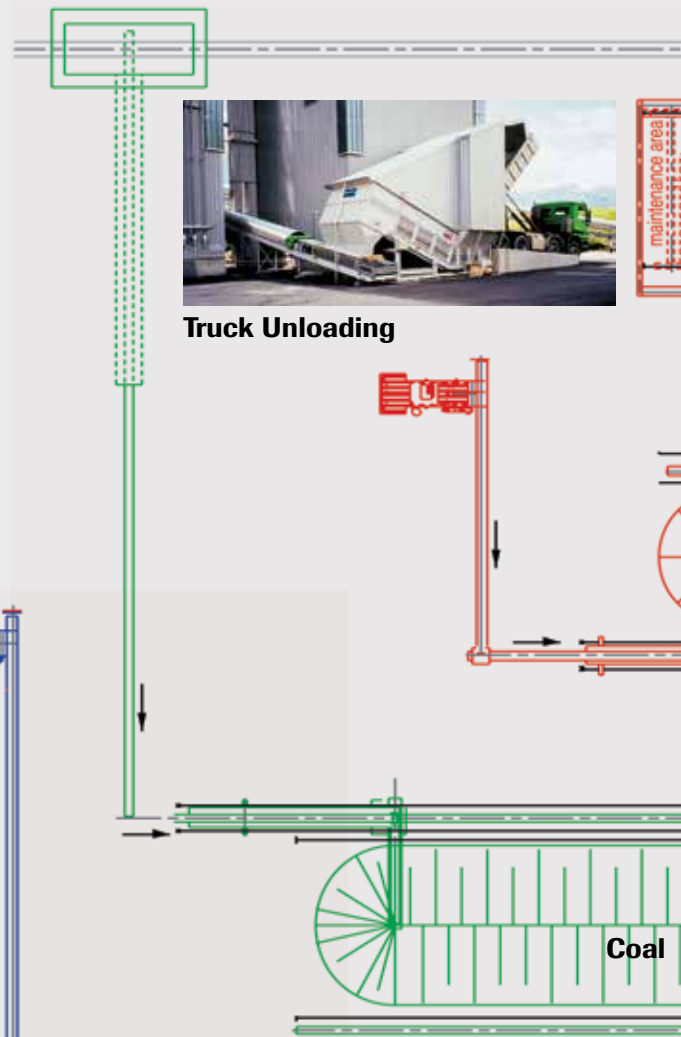

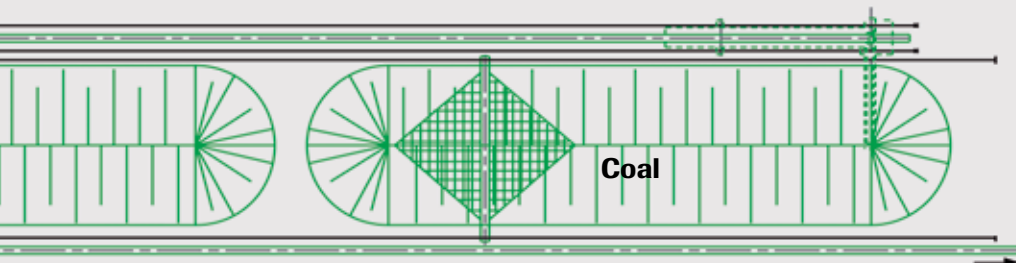
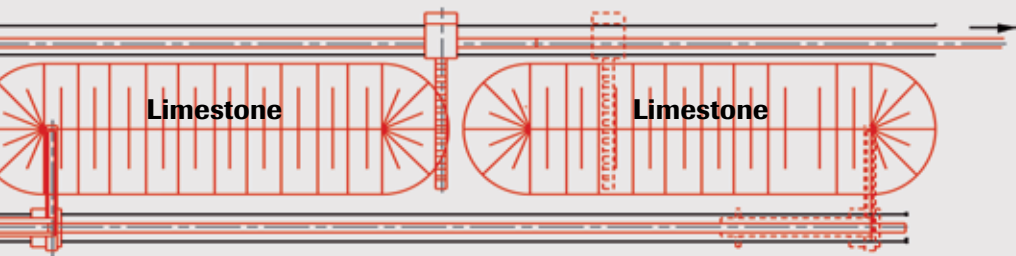
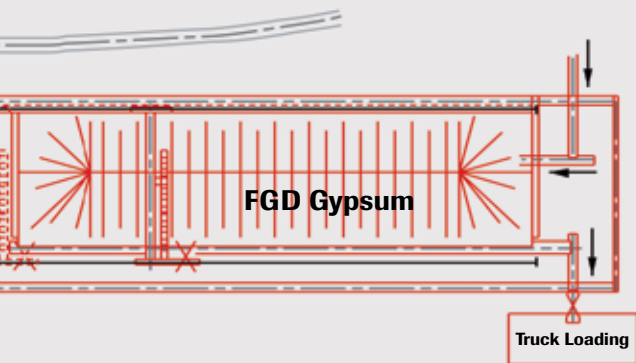

After Sales Service and Retrofits

Service to our customers is of prime importance, even after successful completion of planning, design, manufacture and delivery.

Field Services

The high degree of specialisation of our field service engineers is a major asset to our service. Supervisors with expert knowledge of all SCHADE products are available at short notice.

- Supervisor Services
- Field Assembly
- Test runs and commissioning
- Technical assistance
- Training of operating staff

Spare Parts

A comprehensive range of genuine spare parts is available for our entire product range. Our service staff assists in choosing the relevant spare parts and issues quotes at short notice.

Conversions and Retrofits

Specialised engineers provide tailor-made solutions for modernisations, refurbishments or retrofits with the prime target being to increase the capacity or to improve the degree of availability of existing installations with low capital cost. Conversions are based on thorough investigation including advice on structural integrity and are designed to optimise the existing plant section by improving or replacing major equipment components, keeping in mind a value approach that guarantees a high technical standard at reasonable cost.



Retrofit situation during capacity increase



Erection, Retrofit & Commissioning

Our qualified specialists guarantee the highest standard of installation and commissioning.

The SCHADE staff is always trained to the cutting edge of technology.

This allows for great longevity of the installation for many years.



Erection of the portal by chain



Main boom with shovel and chain



Installation of a shovel



SCHADE
AUMUNDGROUP



SAMSON
AUMUNDGROUP





AUMUND Group Spanning the Globe

The AUMUND Group offers efficient solutions for conveying and storage of bulk materials. A particular strength is the technologically mature and extremely reliable machinery for handling all kinds of bulk materials, even hot, abrasive or sticky. More than 18,000 installations worldwide substantiate the excellent reputation and good market position of the Group. The companies of the AUMUND Group are active in more than 140 countries with 15 locations all over the world and a global network of almost 100 representatives.

- AUMUND** Holding B.V. / The Netherlands
- AUMUND** Fördertechnik GmbH / Germany
- AUMUND** Rep. Office St. Petersburg / Russia
- AUMUND** S.A.R.L. / France
- AUMUND** Machinery Trading (Beijing) Co. Ltd. / China
- AUMUND** Asia (H.K.) Ltd. / Hong Kong SAR
- AUMUND** Corporation / USA
- AUMUND** Ltda. / Brazil
- AUMUND** Engineering Private Ltd. / India
- AUMUND** Branch Office Dubai / U.A.E.
- AUMUND** Group Field Service GmbH / Germany
- AUMUND** Logistic GmbH / Germany
- SCHADE** Lagertechnik GmbH / Germany
- SCHADE** Rep. Office Moscow / Russia
- SAMSON** Materials Handling Ltd. / UK

The AUMUND Group operates Service Centres and Warehousing for spare parts in Germany, the USA, Brazil, Hong Kong and Saudi Arabia. Almost 60 dedicated Supervisors tend to clients' needs across the globe and a specialized PREMÁS® Team provides Preventative Maintenance and Service support including inspection and consulting.



SCHADE Headquarters Gelsenkirchen, Germany

SCHADE
AUMUNDGROUP

SCHADE Lagertechnik GmbH

sales@schade-lagertechnik.com · www.schade-lagertechnik.com