

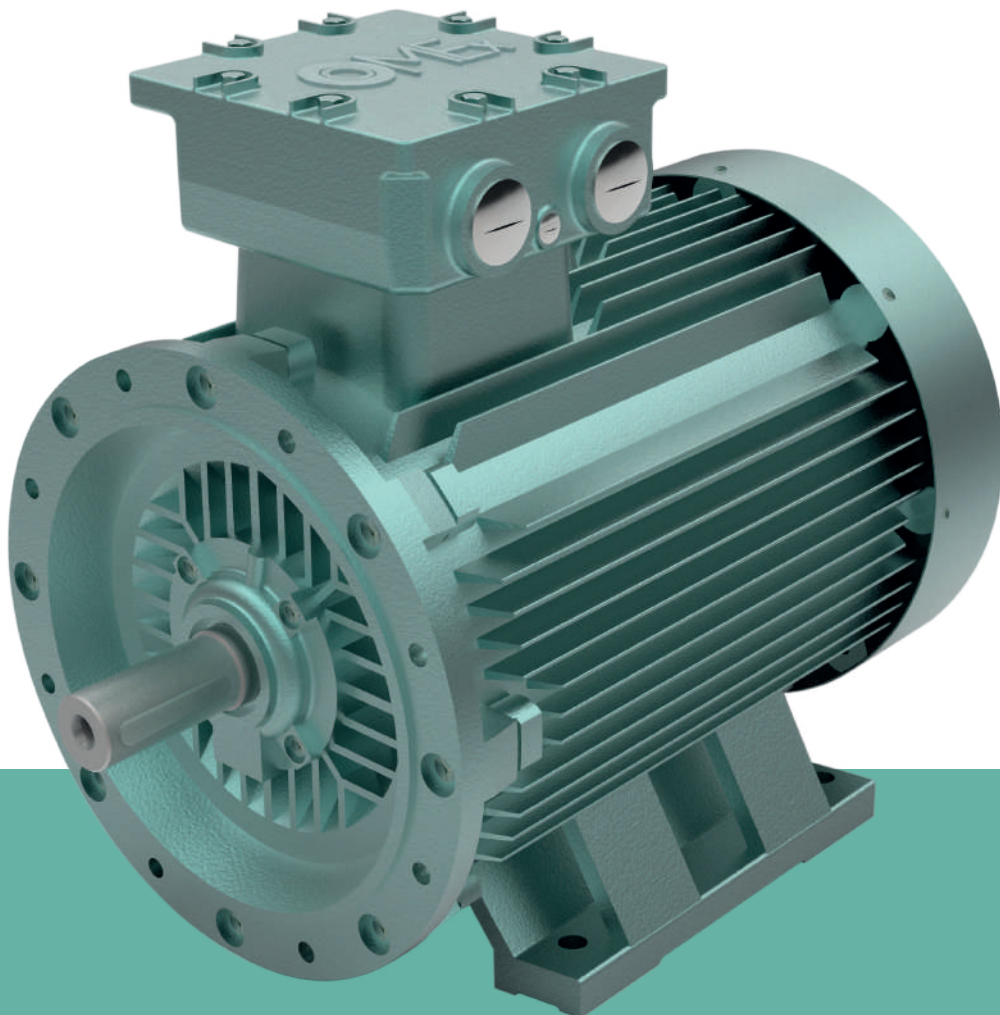

FLAME-PROOF SERIES
THREE PHASE ELECTRIC MOTOR LOW VOLTAGE

www.omemotors.com





FLAME-PROOF SERIES
THREE PHASE ELECTRIC MOTOR LOW VOLTAGE

www.omemotors.com

OMEX series of three phase Explosion-Proof motor is an axial ventilated, totally enclosed fan cooled, squirrel-caged motor.

OMEX motor stands out for its high efficiency, higher torque, higher overload capacity, lower noise, less vibration, larger temperature margin, better performance, easy to install and repair, longer lifespan and other advantages.

It has a rigid explosion-proof body, it is safe and reliable and esthetically beautiful.

The level of technology of the products is of the highest European standard.

The power levels and mounting dimension of these electric motors comply with IEC standards, corresponding to the German standard DIN42673.

OMEX series of Explosion-proof Asynchronous motors (frame sizes 63-355) are designed and manufactured according to IEC60079-0 2007.

Motor Identification Symbol:

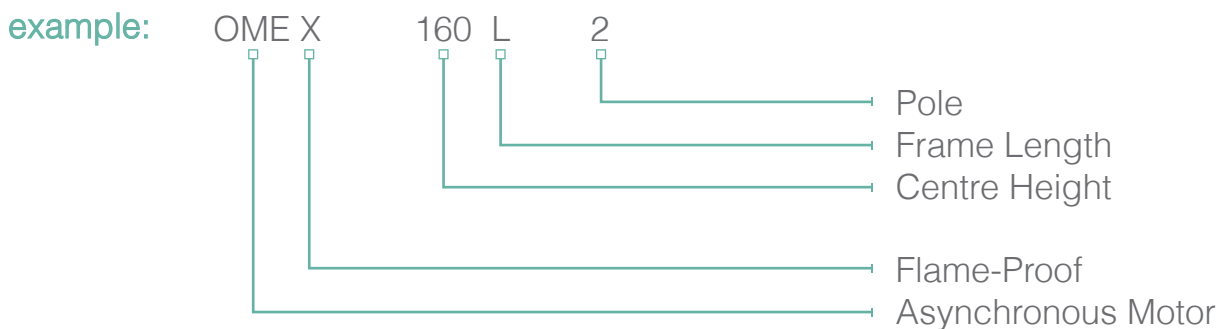

Omex motors are used in:

- chemical industries
- petrochemical industries
- petroleum platforms
- oil pipelines
- gas pipelines
- pharmaceutical industries
- graphic industries
- thermal power stations
- on ships
- manufacturing industries
- in-shore and off-shore platforms

Omex main features:

- Frame size from 80 to 355
- Cast iron casing
- Power from 0.75 to 315 kW
- Three-phase
- 1 speed
- Group IIB
- ATEX category
- Temperature class T4
- Protection IP55
- SKF ball bearings

They are also used by system and equipment manufactures for:

- waste collection and treatment
- cereale, rice, sugar processing
- etc...



II 2G Ex db IIB T4 Gb
II 2D Ex tb IIIC (125°) Db

Standards and specifications

OMEX Explosion-proof motors conform to the following standards and specifications.

Table 1

Title	INTERNATIONAL IEC	EU CENELEC
Electrical rotating machines/rated operation and characteristic data	IEC 60034-1	EN 60034-1
Methods for determining losses and efficiency of rotating electrical machines	IEC 60034-2	EN 60034-2
Types of protection for rotating electrical machines	IEC 60034-5	EN 60034-2
Cooling methods for rotating electrical machines	IEC 60034-6	EN 60034-6
Construction types for rotating electrical machines	IEC 60034-7	EN 60034-7
Terminal markings and direction of rotation for electrical machines	IEC 60034-8	EN 60034-8
Noise emission, limit values	IEC 60034-9	EN 60034-9
Start-up behaviour of squirrel-cage motors at 50 Hz up to 660V	IEC 60034-12	EN 60034-12
Vibration levels of rotating electrical machines	IEC 60034-14	EN 60034-14
Protection level provided by enclosures for electrical equipment against mechanical impact (Code IK)	IEC 60081-1 IEC 60068-2-75	EN 50102
Fixing dimensions and outputs for IM 83	IEC 60072	EN 50347
Fixing dimensions and outputs for IM B5, IM B14	IEC 60072	EN 50347
Cylindrical shaft ends for electrical machines	IEC 60072	EN 60072
Electrical equipment for hazardous areas General provisions	IEC 60079-0	EN 60079-0
Electrical equipment for hazardous areas Flame-proof enclosure "d"	IEC 60079-1	EN 60079-1
Electrical equipment for hazardous areas Increased safety "e"	IEC 60079-7	EN 60079-7
Electrical equipment for use in areas with presence of combustible dust – General provisions	IEC 61241-0	EN 61241-0
Electrical equipment for use in areas with presence of combustible dust – Protection method "tD"	IEC 61241-1	EN 61241-1

ATEX Protection Types

The use of electrical equipment in potentially explosive atmospheres is quite common nowadays.

Such equipment has to be manufactured in a way so that there is no risk of explosion.

An explosion occurs when the following three conditions are present:

- Presence of a potentially explosive atmosphere;
- Possibility of transmission of the explosion;
- Existence of an ignition source

The recognized types of protection eliminate one of these conditions and thus make an explosion impossible.

In practice, four types of protection are applicable to electric motors:

- Pressurized apparatus (symbol Ex p);
- Flameproof enclosure (symbol Ex d);
- Increased safety (symbol Ex e);
- Non sparking protection (symbol Ex n);

Flameproof motors have an additional type of protection (symbol Ex de) which is a combination of:

- Flameproof enclosure “d” for motor frame;
- Increased safety “e” for terminal box.

Fig. 1 – Specific marking for protection against explosions – Directive 94/9/EC

Dangerous areas and zones

Dangerous areas include any area in which explosive atmospheres may occur under specific conditions.

An explosive atmosphere is a mixture of air and combustible gases, vapours, fumes or dust under atmospheric conditions where combustion expands itself (explosion) after ignition.

The user shall classify the hazardous areas as indicated in the European directive 1999/92/EC under his own responsibility.

International standards IEC 61241-10 provide instructions on how to classify the hazardous areas in relation to the chemical nature, to the physical characteristics and to the amount of substances used and based on the frequency and period of time in which an explosive mix may develop.

Zones susceptible to gas

When the hazard is due to the presence of gas, vapours or mixture of flammable substances, the European directive 1999/92/EC classifies in three zones defined as follows:

Zone 0 - Areas which are susceptible to an explosive atmosphere constantly or for long periods of time. Power equipment with double level of protection must be installed in this area.

Zone 1 - Areas where an explosive atmosphere is likely to develop during normal conditions.

Flameproof electric motors or motors with added protection means can be installed in this zone (for the latter, restrictions by the standards apply).

Zone 2 - Areas rarely susceptible to an explosive atmosphere and for a short period of time.

Flameproof electric motors or motors with added protection can be installed in this zone, as well as non-sparking motors.

Zones susceptible to combustible dust
When the hazard is due to the presence of combustible dust, the European directive 1999/92/EC classifies three zones defined as follows:

Zone 20 - Areas which are susceptible to an explosive atmosphere constantly or for long periods of time.

Power apparatus cannot be installed in this zone.

Zone 21 - Areas where an explosive atmosphere is likely to develop during normal conditions.

Electric motors certified in compliance with the ATEX directive with IP6X protection rating can be installed in this zone.

Zone 22 - Areas rarely susceptible to an explosive atmosphere, and only for a short period of time. In the presence of conductive dust, electric motors certified in compliance with the ATEX directive with protection rating IP6X can be installed in this zone, whereas in the presence of non conductive dust, motors with protection rating IP5X and a declaration of conformity issued by the manufacturer can be installed.

Dangerous areas classified into zones:

Table 2

Usage area in the presence of GAS	Usage area in the presence of COMBUSTIBLE DUSTS	Hazardous level of the operational ZONE
Zone 0	Zone 20	Explosive atmosphere ALWAYS PRESENT
Zone 1	Zone 21	PROBABLE explosive atmosphere
Zone 2	Zone 22	Explosive atmosphere UNLIKELY

Apparatus classification

The ATEX 94/9/EC European Directive classifies equipment into three categories, with different protection levels, related to the protection guaranteed.

Equipment of higher categories can also be installed in the place of those of lower categories.

Equipment categories:

Table 3

PROTECTION LEVEL guaranteed by the equipment Category	MINE	SURFACE	
	Category	GAS Category	COMBUSTIBLE DUST Category
Very high	M1	1G	1D
High	M2	2G	2D
Normal	not provided for	3G	3D

Enclosure groups

The standards classify electrical equipment into two groups.

Group I: Electric equipment to be installed in mines or tunnels susceptible to firedamp and coal dust.

Group II: electric apparatus to be installed in surface plants susceptible to other explosive atmospheres.

The enclosures for equipment intended for use on the surface, providing “d” protection (flameproof), are divided into three sub-groups, in relation to the inflammable substances for which they are suitable: Group IIA, Group IIB, Group IIC.

A motor that belongs to a certain enclosure group is also suitable for lower enclosure groups: a motor in group IIB is also suitable for group IIA; a motor in group IIC is also suitable for group IIA and IIB.

Temperature classes (for gas atmospheres)

Electrical equipment are classified into 6 classes according to the maximum surface temperatures (See Table 4).

The maximum surface temperature is the highest temperature which can be attained by any part of the electrical device in service under the conditions described in the standard and which could ignite the surrounding atmosphere.

For electric motors this is:

- The temperature of the outside surface of the enclosure for “d” and “p” protection modes;
- The temperature of any internal or external point for protection type "e" or "n".

Ignition temperature of the environment relative to limit:

Table 4

temperature [°C]	Temperature class	Maximum surface temperature of electrical equipment including 40°C ambient
Over 450	T1	450
From 300 to 450	T2	300
From 200 to 300	T3	200
From 135 to 200	T4	135
From 100 to 135	T5	100
From 85 to 100	T6	85

Combustion temperatures of gases, vapours and groups

Combustible gases and vapours are divided into classes according to their ignition temperature and into groups according to their explosive capacity.

Markings on motors and other electrical equipment with the symbols used to indicate the protection mode, the enclosure group, and the temperature class, specify the zone in which such equipment can be installed.

Temperature for atmospheres with combustible dusts

The flash point of the dust must be taken into account in providing protection against flammable dust, where this is both in cloud form and in layers (see Table 5).

The surface temperature of the enclosure indicated on the motor nameplate must be less than the reference ignition temperature.

The reference temperature is the lowest between the two values calculated as follows:

TS1 = - T_{cl} (T_{cl} – ignition temperature of the cloud of dust)

TS2 = - T_{5mm} – 75K (T_{5mm} – ignition temperature of a 5mm layer of dust)

Examples of flash points for combustible dusts:

Table 5

	Cloud [°C]	Layer [°C]
Wheat	420	200
Barley	450	205
Corn	400	250
Sugar	350	220
Lignite	450	200
Sulphur	190	220

Choice of safety-electric motor

The relationship between hazardous zones and the categories of equipment to be used is defined in Directive 1999/92/EC.

The specific construction standards for the protection modes (e.g. Ex d) also define the motor category that can be obtained by applying the standards (e.g. 2G).

Equipment of a higher category can be installed in place of equipment of a lower category.

Choosing the protection mode for zones in which gas is present:

Table 6

Explosive atmosphere	Danger Zone	Protection guaranteed by Equipment	Equipment Category	Protection Mode
ALWAYS PRESENT	0	Very High	1G	IEC EN 60079-26
PROBABLE	1	High	2G	Ex d
IMPROBABLE	2	Normal	3G	Ex nA

Choice of protection mode for areas where combustible dust is present:

Table 7

Explosive atmosphere	Danger Zone	Protection guaranteed by Equipment	Equipment Category	Protection Mode
ALWAYS PRESENT	20	Very High	1D	Currently not provided
PROBABLE	21	High	2D	Ex tD – A21 – IP6x
IMPROBABLE	22 Non-Conductive Dust	Normal	3D	Ex tD – A22 – IP5x

Certification and approved laboratories

The motors offered in this catalogue comply with the ATEX Directive 94/9/EC which states that two different certificates of conformity are to be issued:

- EC Type examination certificate
- Product quality assurance notification.

Certification:

Flameproof motors must be approved by a notified body appointed by the European Commission according to the methods defined by the same ATEX directive.

The motors are classified based on the hazardous atmosphere of the place of installation.

The type of motor protection must be chosen on the basis of the area of installation. The level of risk of the zone is determined by the atmosphere involved.

The user is responsible for determining the type of protection, enclosure group, and maximum surface temperature of the motor to be installed.

The user must also correctly install, connect to the mains, use and service the motor. Certificates of conformity to CENELEC standards are valid in all member countries in the European Union and member countries of CENELEC.

The nominal characteristics of motors relate to a maximum ambient temperature of 40°C.

Range of motors in the ATEX series

The motors offered in this catalogue comply with standards concerning equipment and protective systems intended for use in potentially explosive atmospheres, in compliance with European Directive 94/9/EC, otherwise known as the ATEX directive. The ATEX directive states that two different certificates of conformity are to be issued.

One is the “EC-Type examination certificate” for the homologation of the prototype and the other is for the “Production Quality Assurance Notification”.

Main characteristics

- Flameproof motors comply with the Standards IEC EN 60079-0, 60079-1, 60079-7 for atmospheres where gas is present and IEC EN 61241-0, 61241-1 for areas where combustible dust is present.
- F insulation class.
- Noise level according to EN 60034-1
- Terminal Box:
 - Available in the flameproof
 - Located on the top as standard
 - Can be rotated in four positions.
- Motor frame and terminal box enclosure from 80 up to 355 are separated to avoid the transmission of explosions.
- Winding cables are connected to the terminal box through the terminal blocks or by flameproof bushings.
- Mechanical components are painted with protective paints:
 - stainless steel nameplate;
 - anti-corrosion screws.
- Cast iron frame, terminal box and endshields are highly resistant to impact.
- The conformity certificates also cover alternatives, such as:
 - altitude up to 1000 m
 - modification of the rated voltage and rated frequency
 - power supply from an inverter
 - motor protection through temperature detectors

Main options

Electrical variants

- Non-standard voltages and frequencies (maximum voltage 690V)
- Motors for tropical climates
- Motors for low temperatures (-55°)
- Motors for high temperature (+55°)
- Motors insulated to class H
- Motors with thermistor PTC or PT100 sensor
- Motors with anti-condensation heaters
- Motors with Klixon.

Mechanical variants

- Special flanges and shafts
- Double ended shafts
- Cable gland fitted to terminal box
- Terminal box with metric or IPE cable entries
- Grade A or B balancing
- Motors with a rain canopy or sun shield, water-shedding disc.
- High protection against corrosion for tropical climates or applications in marine environments:
 - external mechanical components finished with epoxy paint;
 - protection of the internal parts (winding and rotor) with protective paint;
 - stainless steel screws.
 - roller bearings

Accessories

- Motors suitable for frequency inverter drive with insulated bearings too.

Mounting arrangements

The most commonly used mounting arrangements are shown in the table 8. Other mounting arrangements are available on request.

Standard motors ordered in basic mounting arrangements (universal mounting arrangements) IM B3, IM B5 or IM B14 can also be operated in the following different mounting positions:

- IM B3 in IM B6, IM B7, IM B8, IM V5 or IM V6,
- IM B5 in IM V1 or IM V3,
- IM B14 in IM V18 or IM V19

According to the safety standard for electrical machines, foreign objects must be prevented from falling into the fan cover.

Motors for vertical arrangement with shaft end down are fitted with a protection canopy over the fan cover.

Installation, mechanical enclosure and cooling

Standard installation

The motors can be installed outdoors and in moist and chemically aggressive environment (industrial climate) at ambient temperatures from -20°C to 40°C.

Mechanical protection (IP)

The mechanical protection systems for electric motors are classified with the IP code followed by two numbers and, in some applications, by a letter.

IP (International Protection):

This indicated the level of protection against accidental contacts of foreign bodies and against water.

0 – 6 (1st digit):

Degree of protection against external solid bodies.

0 – 8 (1nd digit):

Degree of protection against the penetration of external liquid bodies.

The additional letter provides information relating to material protection (H-M-S-W).

Cooling

Motors are air-cooled by means of external surface ventilation (IC 411). Standard motors have radial fan allowing reversible rotation. Reference standards are : IEC 60034-6.

Shaft ends, balancing, vibrations, noise levels, coupling and belt drives

Shaft ends

The shaft ends are cylindrical and comply with IEC 60072. The shaft ends of all motors are equipped with a tapped hole to enable the fitting of pulleys and couplings. The keys are always supplied along with the motors. On request, special shaft ends or a second reserve shaft end can be provided.

Balancing, and vibration

The motors are dynamically balanced with half keys in accordance with vibration grade °A° (former N) normal balance IEC 60034-14. The low-vibration version °B° (former R) (reduced) can be supplied where high demands are made on quiet running.

Coupling drive

When aligning a motor to be coupled directly to the machine, care must be taken so that the balls of the bearings do not jam. Elastic couplings can be used with all motors. To ensure that it functions without vibrations and to avoid excessive stress on the bearings, the machine to be coupled must be exactly aligned in the case of elastic coupling. Maximum accuracy must be applied to the coupling of 2-pole motors.

Belt drive

Side rails are used for motors for easy tensioning and readjustment at the belts. Permissible radial forces have to be taken into consideration (See Table 10). Pulleys and couplings must only be fitted and removed using specific tools.

Standard operating conditions

Output

The rated outputs and operating characteristics given in the performance data refer according to IEC 60034-1 to:

- continuous duty (S1)
- frequency of 50Hz
- voltage 230V - 400V and 400V - 690V
- maximum ambient temperature of 40°C
- maximum height of installation of 1000m above sea level.

Motors can also operate in ambient temperatures from 40°C up to 60°C and at altitudes of more than 1000m up to 3000 m above sea level. In these cases the rated output given in the tables must be reduced in accordance with figure 2 or a larger motor has to be chosen. The rated data does not need to be changed if at altitudes in excess of 1000 m above sea level the ambient temperature is reduced according to the table.

Figure 2

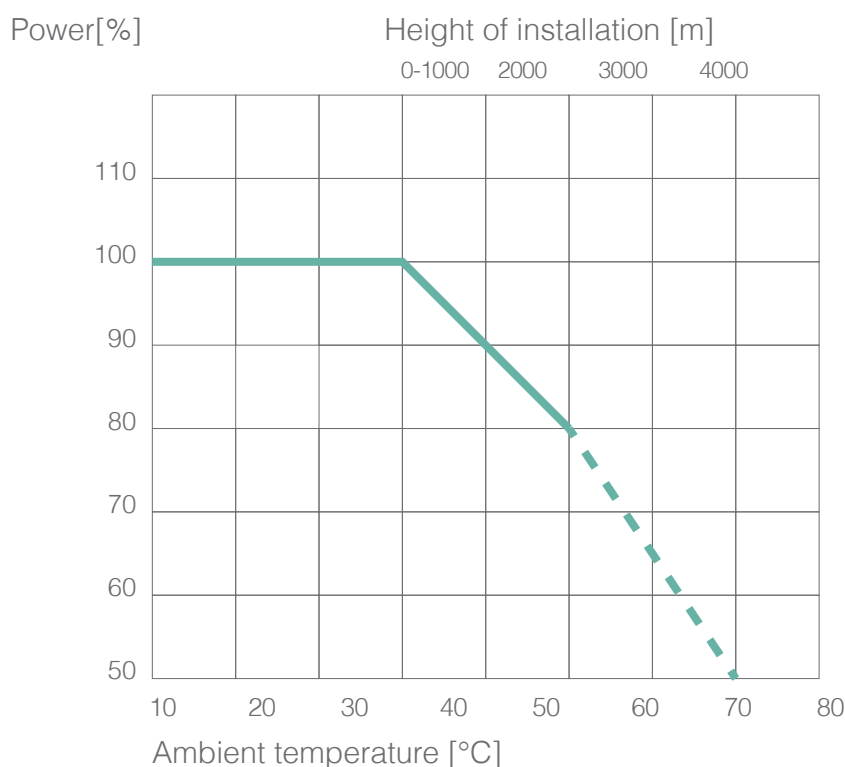

Table 8

Altitude of installation [m]	Maximum ambient temperature [°]
0 to 1000	40
1000 to 2000	30
2000 to 3000	19

Voltage

The motors can run with a voltage fluctuation of $\pm 5\%$ in normal operational areas.

Torque

The motors are fitted with squirrel-cage rotors suitable for direct-on-line starting.

The resulting starting and maximum torques, expressed as a multiple of the rated torques are given in the performance data. A deviation in the voltage from the rated approximate function of the square of the voltages.

Rated current

The rated currents are indicated for a rated voltage of 400V in the table of performance data.

For other voltages the rated currents are inversely proportional to the voltages:

Speed

The rated speeds shown in the performance data are valid for 50Hz and the rated speed equals synchronous speed less slip.

The following speeds result from the number of poles and the supply frequencies of 50 and 60 Hz:

Table 9

Pole number	Asynchronous speed at	
	50Hz [rpm]	60Hz [rpm]
2	3000	3600
4	1500	1800
6	1000	1200
8	750	900

Direct of rotation

The motors can be operated in both directions of rotation. The direction of rotation can be reversed by interchanging any two phases.

Note regarding electro-magnetic compatibility

Low voltage induction motors, if installed correctly and connected to the power supply, respect all immunity and emission limits as set out in the regulations relating to electro-magnetic compatibility (EMC “Generic Standard” for industrial environments).

In the case of power supply by means of electronic impulse devices (such as inverters, soft starters. Etc), all verifications and any modification necessary to ensure that emission and immunity limits as stated within the regulations are respected are the responsibility of the installer.

Tolerances

According to IEC 60034-1 the electrical data stated in the tables are subject to the following tolerances:

Table 10

Efficiency: Pn ≤ 50kW Pn > 50kW	-15% (1-) -10% (1-)
Power factor	- (1-cos) (minimum 0.02-maximum 0.07)
Split at rated load operating temperature	±30% for motors with Pn < 1kW
	±20% for motors with Pn ≥ 1kW
Initial starting current	±20% of guaranteed value
Initial starting torque	15% ... +25% of the guaranteed value (+25% only express demand)
Maximum torque	-10% of the torque guaranteed value, with the specification that after applying this tolerance, the torque should remain equal or higher than 1.6 or 1.5 t

Insulation and temperature rise

Insulation

The components of the insulation system were selected to ensure good protection against chemically aggressive gases, vapours, oil and air humidity.

All materials used for insulating the winding and winding ends correspond to insulating classes F or H according to IEC 60085:

- Enamel-insulated copper wires with temperature index 180°C or 200°C;
- Insulating sheet on polyester base (class F);
- Impregnation with class F or H varnishes.

Limit temperature for insulating material according IEC 60085

Table 11

Insulation class	Limit temperature[°C]
B	130
F	155
H	180

Temperature rise limit for rotating machines according IEC 60034-1

Table 12

Insulation class	Max temperature rise [K]
B	80
F	105
H	125

Connection diagram

Star and delta connection motors are as follows:

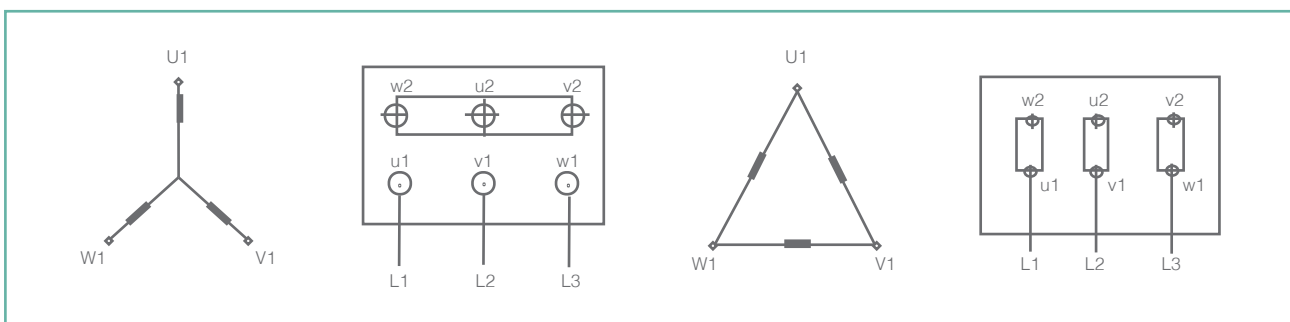

Protection devices

In order to protect the winding of a three-phase induction motor against thermal overloads, (resulting for example for overloading or operation in two phases), one of the following devices can be provided:

- **PTC temperature sensor** motors of the sizes 80-355 have 3 sensors connected in series embedded in stator windings. Once the operating temperature is attained, this device quickly change the resistance; it must be connected to a suitable releasing device (supplied only on request)

- **PT 100 (RTD) thermometric resistors** for motor sizes 80-355. The resistance value of this device varies according to the windings temperature. They are particularly suitable for a continuous survey of the windings temperature. PTC and PT 100 also ensure reliable protection for operating modes other than continuous operation, e.g. short-time operation, switching operation, longtime start-up, such as reduced cooling air flow rates and high ambient temperatures.

Motors for operation with frequency converter are always supplied with PTC thermistor temperature detectors.

Frequency converter driven motors

Motors with enclosures of protection type "d", "de" are designed for variable speed drives.

When using a squirrel cage "Ex d" motor with a frequency converter the following points must be taken into account in addition to the general

Voltage provided by frequency converter is not completely sinusoidal. It will cause a change in distribution losses of motor with an increase of their direct effect on the winding temperature. Also, the motor ventilation is reduced at sub-nominal speed. For this reason, when choosing a motor for an adjustable driven system special attention should be given to a correct dimensioning of the motor according to the data, curve $M = t$ (Hz) - shown in fig. 3.

For any frequency range, the required operating torque must have a lower value than the feature's mentioned before. The converter must be provided with an entry filter to correct the voltage wave shape, improving the operation of the motor by lowering losses and noise. The converter must ensure a variation of the voltage, as follow:

- for 5 ÷ 50Hz range (U / f) = constant
- for 50 ÷ 100Hz range, U = constant

The maximum distance between the motor and converter and the power supply cable that are mentioned in Table 17. Only symmetrical and screened power supply cables will be used and the connections to earth terminals shall be properly made in order to avoid voltage through motor shaft and current flow through the bearings.

The insulation system of motor supplied by frequency converter is subject to higher dielectric stress than in the case of supplying with sinusoidal voltage and current. The type motors supplied by frequency converter in this catalogue have the level of insulation designed for a voltage of 700 V, even if the values of the supply nominal voltage are generally lower. Testing the insulation will be performed at a voltage 2000 V.

Diagram 1

Main Body Structure Diagram

1. Bearing outer cover
2. End shield
3. Bearing Inner cover
4. Terminal Box
5. Stator
6. Rotor
7. Frame Base
8. Bearing
9. Fan Cover
10. Fan
11. Earthling Terminals

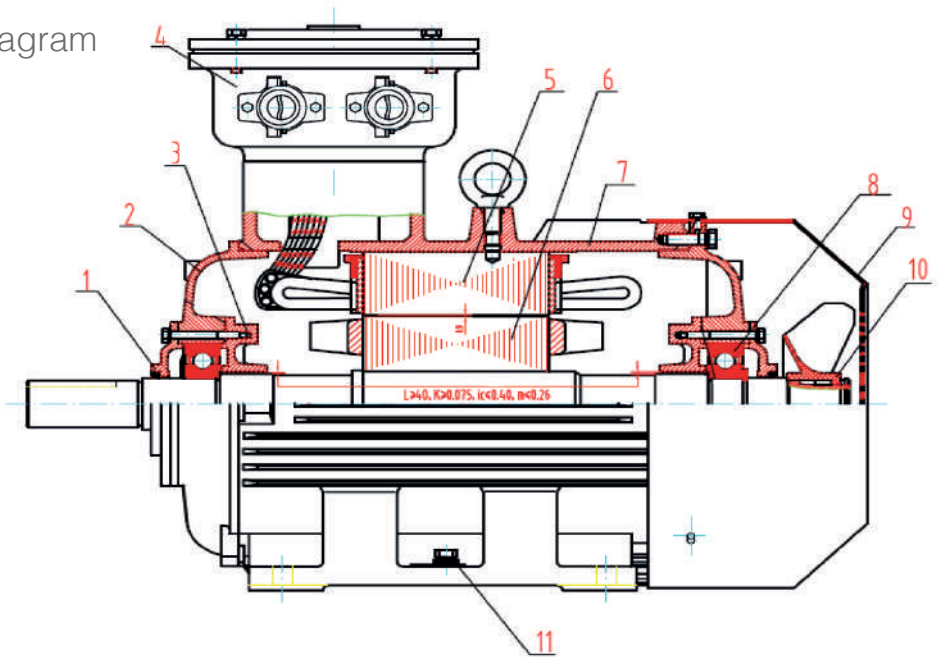
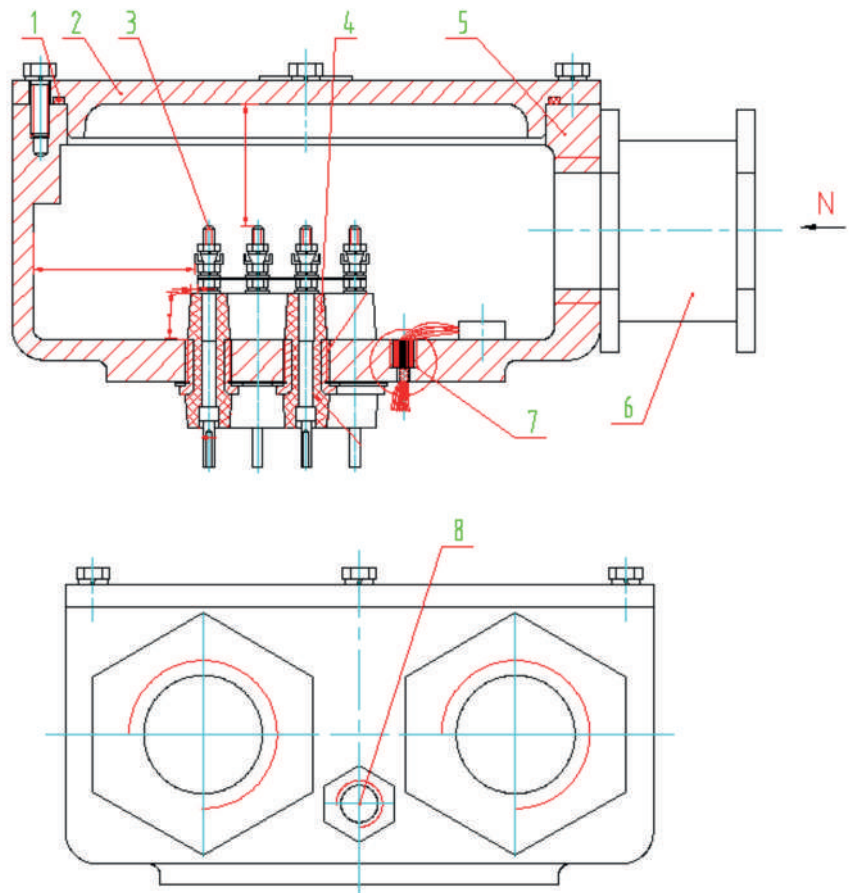

Diagram 2

Terminal Box Structure Diagram

1. O-ring
2. Cover
3. Terminal Block
4. Block Blush
5. Box seat
6. Connector
7. Thermistor lead hole
8. Connector



This series motor with output power 3KW and below using Y connection(380V), other output power using Δ connection (380V), Y connection (660V). Voltage with 660/1140V, if 660V using Δ connection, if 1140V using Y connection.

Terminal box inlets and specification are shown in Table 13

Table 13

Terminal Box Specs	Frame size	Inlets No	Max. External diameter of the connecting cable.	Available Range
Small M5	80~90	Single	25	Normal
M5	100~112	Single	30	Normal
M6	132~180	Single	35	Normal
M8	200~225	Single	42	Normal
M10	250~280	Single	50	Normal
M10	250~280	Double	42	Special
M16	315~355	Single	64	Normal
M16	315~355	Double	50	Special

Cable entry for three phase motor's power supply.

Table 14

Type	Standard IEC 423	
80 - 132	M32*1,5	can be provided on client's request
160 - 180	M40*1,5	can be provided on client's request
200 - 225	M50*1,5	can be provided on client's request
250 - 280	M63*1,5	can be provided on client's request
315 - 355	M75*1,5	can be provided on client's request
for heater or PTC	M20*1,5	

Bearing

Electric motor has special ball bearing which can efficiently reduce the vibration and noise level when running. The models are shown on Table 3. The temperature in the ball bearings does not have to exceed 95°C.

Table 15

Frame size	Pole	DE	N-DE
80	ALL	6204-2RZ	6204-2RZ
90	ALL	6205-2RZ	6205-2RZ
100	ALL	6206-2RZ	6206-2RZ
112	ALL	6206-2RZ	6206-2RZ
132	ALL	6208-2RZ	6208-2RZ
160	2	6209/V2	6209/V2
	4 ~8	6309/V2	6209/V2
180	2	6211/V2	6211/V2
	4 ~8	6311/V2	6211/V2
200	2	6212/V2	6212/V2
	4 ~8	6312/V2	6212/V2
225	2	6312/V2	6312/V2
	4 ~8	6313/V2	6312/V2
250	2	6313/V2	6313/V2
	4 ~8	6314/V2	6313/V2
280	2	6314/C3	6314/C3
	4 ~8	6317/C3	6314/C3
315	2	6316/V2	6316/V2
	4 ~10	NU319	NU319
355	2	6319/Z2	6319/Z2
	4 ~10	NU322	6322/Z2

Technical data

Table 16

Frame size	r/min synchronous speed				
	3000	3000	1000	750	600
	kW Output Power				
80A	0.75	0.75	0.37	0.18	
80B	1.1	1.1	0.55	0.25	
90S	1.5	1.5	0.75	0.37	
90L	2.2	2.2	1.1	0.55	
100L	3	3	1.5	0.75	
				1.1	
112M	4	4	2.2	1.5	
132S	5.5	5.5	3	2.2	
	7.5	7.5			
132M	—	—	4	3	
			5.5		
160M	11	11	7.5	4	
	15	15		5.5	
160L	18.5	18.5	11	7.5	
180M	22	22	—	—	
180L	—	—	15	11	
200L	30	30	18.5	15	
	37	37	22		
225S	—	—	—	18.5	

225M	45	45	30	22	
250M	55	55	37	30	
280S	75	75	45	37	
280M	90	90	55	45	
315S	110	110	75	55	45
315M	132	132	90	75	55
315A	160	160	110	90	75
315B	200	200	132	110	90
355S	(185)(200)	(185)(200)	160	132	(90)
355M	(220) 250	(220) 250	(185) 200	160	110 132
355L	(280) 315	(280) 315	(220) 250	(185) 200	160 (185)

Remark:

- 1) () is non-recommended type
- 2) Numbers after S.M.L means different output power with same frame size, same synchronous speed

Table 17
IE1 - 2 Poles

Type	Rated Output (Kw)	100% Load		A Rated current			Rated Speed (rpm)	Ts/Tn	Tmax/Tn	Is/In
		Efficiency %	Power Factor cos	230 V	400 V	690 V				
3000 (r/min)										
OMEX-80A2	0,75	72,10	0,83	3,15	1,81	1,05	2850	2,3	2,3	6,8
OMEX-80B2	1,1	75,00	0,83	4,44	2,55	1,48	2840	2,3	2,3	7,3
OMEX-90S2	1,5	77,20	0,84	5,81	3,34	1,94	2850	2,3	2,3	7,6
OMEX-90L2	2,2	79,70	0,85	8,15	4,69	2,72	2850	2,3	2,3	7,8
OMEX-100L2	3	81,50	0,88	10,50	6,04	3,50	2880	2,3	2,3	8,1
OMEX-112M2	4	83,10	0,88	13,73	7,90	4,58	2890	2,3	2,3	8,3
OMEX-132SA2	5,5	84,70	0,88	18,52	10,65	6,17	2900	2,2	2,3	8
OMEX-132SB2	7,5	86,00	0,88	24,88	14,30	8,29	2900	2,2	2,3	7,8
OMEX-160MA2	11	87,60	0,88	35,82	20,60	11,94	2930	2,2	2,3	7,9
OMEX-160MB2	15	88,70	0,89	47,70	27,43	15,90	2930	2,2	2,3	8
OMEX-160L2	18,5	89,30	0,89	58,43	33,60	19,48	2930	2,2	2,3	8,1
OMEX-180M2	22	89,90	0,90	68,26	39,25	22,75	2940	2,2	2,3	8,2
OMEX-200LA2	30	90,70	0,90	92,26	53,05	30,75	2950	2	2,3	7,5
OMEX-200LB2	37	91,20	0,90	113,16	65,07	37,72	2950	2	2,3	7,5
OMEX-225M2	45	91,70	0,90	136,88	78,70	45,63	2970	2,2	2,3	7,6
OMEX-250M2	55	92,10	0,90	166,57	95,78	55,52	2970	2,2	2,3	7,6
OMEX-280S2	75	92,70	0,91	223,18	128,33	74,39	2975	2	2,3	6,9
OMEX-280M2	90	93,00	0,91	266,96	153,50	88,99	2975	2	2,3	7
OMEX-315S2	110	93,30	0,91	325,23	187,01	108,41	2980	2	2,2	7,1
OMEX-315M2	132	93,50	0,90	393,77	226,42	131,26	2980	2	2,2	7,1
OMEX-315LA2	160	93,80	0,91	470,54	270,56	156,85	2980	2	2,2	7,1
OMEX-315LB2	200	94,00	0,92	580,55	333,82	193,52	2980	2	2,2	7,1
OMEX-355MB2	250	94,00	0,92	725,69	417,27	241,90	2985	2	2,2	7,1
OMEX-355LB2	315	94,00	0,92	914,36	525,76	304,79	2985	2	2,2	7,1

IE1 - 4 Poles

Type	Rated Output (Kw)	100% Load		A Rated current			Rated Speed (rpm)	Ts/Tn	Tmax/Tn	Is/In
		Efficiency %	Power Factor cos	230 V	400 V	690 V				
1500 (r/min)										
OMEX-80B4	0,75	72,10	0,77	3,39	1,95	1,13	1390	2,3	2,3	6,5
OMEX-90S4	1,1	75,00	0,77	4,78	2,75	1,59	1390	2,3	2,3	6,6
OMEX-90L4	1,5	77,20	0,79	6,17	3,55	2,06	1390	2,3	2,3	6,9
OMEX-100LA4	2,2	79,70	0,81	8,55	4,92	2,85	1420	2,3	2,3	7,5
OMEX-100LB4	3	81,50	0,82	11,27	6,48	3,76	1420	2,3	2,3	7,6
OMEX-112M4	4	83,10	0,82	14,74	8,47	4,91	1430	2,3	2,3	7,7
OMEX-132S4	5,5	84,70	0,84	19,41	11,16	6,47	1450	2	2,3	7,5
OMEX-132M4	7,5	86,00	0,85	25,76	14,81	8,59	1450	2	2,3	7,4
OMEX-160M4	11	87,60	0,85	37,08	21,32	12,36	1460	2,2	2,3	7,5
OMEX-160L4	15	88,70	0,85	49,94	28,72	16,65	1460	2,2	2,3	7,5
OMEX-180M4	18,5	89,30	0,85	61,18	35,18	20,39	1470	2,2	2,3	7,7
OMEX-180L4	22	89,90	0,85	72,27	41,56	24,09	1470	2,2	2,3	7,8
OMEX-200L4	30	90,70	0,86	96,55	55,51	32,18	1470	2,2	2,3	7,2
OMEX-225S4	37	91,20	0,87	117,06	67,31	39,02	1480	2,2	2,3	7,3
OMEX-225M4	45	91,70	0,87	141,60	81,42	47,20	1480	2,2	2,3	7,4
OMEX-250M4	55	92,10	0,87	172,31	99,08	57,44	1480	2,2	2,3	7,4
OMEX-280S4	75	92,70	0,87	233,45	134,23	77,82	1480	2,2	2,3	6,7
OMEX-280M4	90	93,00	0,87	279,23	160,56	93,08	1480	2,2	2,3	6,9
OMEX-315S4	110	93,30	0,88	336,32	193,38	112,11	1485	2,2	2,2	6,9
OMEX-315M4	132	93,50	0,88	402,72	231,56	134,24	1485	2,2	2,2	6,9
OMEX-315LA4	160	93,80	0,89	481,12	276,64	160,37	1485	2,2	2,2	6,9
OMEX-315LB4	200	94,00	0,89	600,12	345,07	200,04	1485	2,2	2,2	6,9
OMEX-355MB4	250	94,00	0,90	741,81	426,54	247,27	1490	2,2	2,2	6,9
OMEX-355LB4	315	94,00	0,90	934,68	537,44	311,56	1490	2,2	2,2	6,9

IE1 - 6 Poles

Type	Rated Output (Kw)	100% Load		A Rated current			Rated Speed (rpm)	Ts/Tn	Tmax/Tn	Is/In
		Efficiency %	Power Factor cos	230 V	400 V	690 V				
1000 (r/min)										
OMEX-90S6	0,75	70,00	0,72	3,74	2,15	1,25	910	2,1	2,1	5,8
OMEX-90L6	1,1	72,90	0,73	5,19	2,98	1,73	910	2,1	2,1	5,9
OMEX-100L6	1,5	75,20	0,76	6,59	3,79	2,20	930	2,1	2,1	6
OMEX-112M6	2,2	77,70	0,76	9,35	5,38	3,12	940	2,1	2,1	6
OMEX-132S6	3	79,70	0,77	12,27	7,06	4,09	970	2,1	2,1	6,2
OMEX-132MA6	4	81,40	0,74	16,67	9,59	5,56	970	2	2,1	6,8
OMEX-132MB6	5,5	83,10	0,75	22,15	12,74	7,38	970	2	2,1	7,1
OMEX-160M6	7,5	84,70	0,79	28,14	16,18	9,38	970	2,1	2,1	6,7
OMEX-160L6	11	86,40	0,79	40,46	23,26	13,49	970	2,1	2,1	6,9
OMEX-180L6	15	87,70	0,81	53,01	30,48	17,67	980	2	2,1	7,2
OMEX-200LA6	18,5	88,60	0,83	63,15	36,31	21,05	980	2,1	2,1	7,2
OMEX-200LB6	22	89,20	0,83	74,59	42,89	24,86	980	2,1	2,1	7,3
OMEX-225M6	30	90,20	0,86	97,08	55,82	32,36	980	2	2,1	7,1
OMEX-250M6	37	90,80	0,86	118,94	68,39	39,65	980	2,1	2,1	7,1
OMEX-280S6	45	91,40	0,86	143,71	82,63	47,90	980	2,1	2	7,2
OMEX-280M6	55	91,90	0,86	174,69	100,45	58,23	990	2,1	2	7,2
OMEX-315S6	75	92,60	0,86	236,42	135,94	78,81	990	2	2	6,7
OMEX-315M6	90	92,90	0,86	282,78	162,60	94,26	990	2	2	6,7
OMEX-315LA6	110	93,30	0,86	344,14	197,88	114,71	990	2	2	6,7
OMEX-315LB6	132	93,50	0,86	412,09	236,95	137,36	990	2	2	6,7
OMEX-355S6	160	93,80	0,87	492,18	283,00	164,06	995	2	2	6,7
OMEX-355MB6	200	94,00	0,88	606,94	348,99	202,31	995	2	2	6,7
OMEX-355L6	250	94,00	0,88	758,67	436,24	252,89	995	2	2	6,7

IE1 - 8 Poles

Type	Rated Output (Kw)	100% Load		A Rated current			Rated Speed (rpm)	Ts/Tn	Tmax/Tn	Is/In
		Efficiency %	Power Factor cos	230 V	400 V	690 V				
750 (r/min)										
OMEX-100LA8	0,75	71	0,68	3,90	2,24	1,30	690	1,8	2	4
OMEX-100LB8	1,1	73	0,69	5,48	3,15	1,83	690	1,8	2	5
OMEX-112M8	1,5	75	0,69	7,28	4,18	2,43	690	1,8	2	5
OMEX-132S8	2,2	78	0,73	9,70	5,58	3,23	710	1,8	2	6
OMEX-132M8	3	79	0,73	13,06	7,51	4,35	710	1,8	2	6
OMEX-160MA8	4	81	0,73	16,98	9,76	5,66	720	1,9	2	6
OMEX-160MB8	5,5	83	0,75	22,18	12,75	7,39	720	1,9	2	6
OMEX-160L8	7,5	85,5	0,76	28,97	16,66	9,66	720	1,9	2	6
OMEX-180L8	11	87,5	0,76	41,52	23,88	13,84	720	2	2	6,5
OMEX-200L8	15	88	0,76	56,30	32,37	18,77	730	2	2	6,6
OMEX-225S8	18,5	90	0,78	66,15	38,04	22,05	740	1,9	2	6,6
OMEX-225M8	22	90,5	0,78	78,24	44,99	26,08	740	1,9	2	6,6
OMEX-250M8	30	91	0,79	104,76	60,23	34,92	740	1,9	2	6,5
OMEX-280S8	37	91,5	0,79	128,49	73,88	42,83	740	1,9	2	6,6
OMEX-280M8	45	92	0,79	155,43	89,37	51,81	740	1,9	2	6,6
OMEX-315S8	55	92,8	0,81	183,68	105,61	61,23	740	1,8	2	6,6
OMEX-315M8	75	93	0,81	249,93	143,71	83,31	740	1,8	2	6,2
OMEX-315LA8	90	93,8	0,82	293,73	168,90	97,91	740	1,8	2	6,4
OMEX-315LB8	110	94	0,82	358,24	205,99	119,41	740	1,8	2	6,4
OMEX-355S8	132	93,7	0,82	431,27	247,98	143,76	740	1,8	2	6,4
OMEX-355M8	160	94,2	0,82	519,97	298,98	173,32	740	1,8	2	6,4
OMEX-355LB8	200	94,5	0,83	640,09	368,05	213,36	740	1,8	2	6,4

Table 18
IE2 - 2 Poles

Type	Rated Output (Kw)	100% Load		A Rated current			Rated Speed (rpm)	Ts/Tn	Tmax/Tn	Is/In
		Efficiency %	Power Factor cos	230 V	400 V	690 V				
3000 (r/min)										
OMEX-80A2	0,75	77,5	0,83	2,93	1,68	0,98	2850	2,3	2,3	6,8
OMEX-80B2	1,1	82,8	0,83	4,02	2,31	1,34	2840	2,3	2,3	7,3
OMEX-90S2	1,5	84,1	0,84	5,33	3,06	1,78	2850	2,3	2,3	7,6
OMEX-90L2	2,2	85,6	0,85	7,59	4,36	2,53	2850	2,3	2,3	7,8
OMEX-100L2	3	86,7	0,87	9,98	5,74	3,33	2880	2,3	2,3	8,1
OMEX-112M2	4	87,6	0,88	13,03	7,49	4,34	2890	2,3	2,3	8,3
OMEX-132SA2	5,5	88,6	0,88	17,71	10,18	5,90	2900	2,2	2,3	8
OMEX-132SB2	7,5	89,5	0,89	23,64	13,59	7,88	2900	2,2	2,3	7,8
OMEX-160MA2	11	90,5	0,89	34,28	19,71	11,43	2930	2,2	2,3	7,9
OMEX-160MB2	15	91,3	0,89	46,34	26,65	15,45	2930	2,2	2,3	8
OMEX-160L2	18,5	91,8	0,89	56,84	32,68	18,95	2930	2,2	2,3	8,1
OMEX-180M2	22	92,2	0,89	67,30	38,70	22,43	2940	2,2	2,3	8,2
OMEX-200LA2	30	92,9	0,89	91,08	52,37	30,36	2950	2	2,3	7,5
OMEX-200LB2	37	93,3	0,89	111,85	64,32	37,28	2950	2	2,3	7,5
OMEX-225M2	45	93,7	0,89	135,46	77,89	45,15	2970	2,2	2,3	7,6
OMEX-250M2	55	94	0,89	165,03	94,89	55,01	2970	2,2	2,3	7,6
OMEX-280S2	75	94,6	0,89	223,62	128,58	74,54	2975	2	2,3	6,9
OMEX-280M2	90	95	0,89	267,21	153,65	89,07	2975	2	2,3	7
OMEX-315S2	110	95	0,9	322,96	185,70	107,65	2980	2	2,2	7,1
OMEX-315M2	132	95,4	0,9	385,93	221,91	128,64	2980	2	2,2	7,1
OMEX-315LA2	160	95,4	0,91	462,65	266,02	154,22	2980	2	2,2	7,1
OMEX-315LB2	200	95,4	0,91	578,32	332,53	192,77	2980	2	2,2	7,1
OMEX-355MB2	250	95,8	0,91	719,88	413,93	239,96	2985	2	2,2	7,1
OMEX-355LB2	315	95,8	0,91	907,04	521,55	302,35	2985	2	2,2	7,1

IE2 - 4 Poles

Type	Rated Output (Kw)	100% Load		A Rated current			Rated Speed (rpm)	Ts/Tn	Tmax/Tn	Is/In
		Efficiency %	Power Factor cos	230 V	400 V	690 V				
1500 (r/min)										
OMEX-80A4	0,75	82,3	0,75	3,05	1,75	1,02	1390	2,3	2,3	6,5
OMEX-80B4	1,1	83,8	0,75	4,39	2,53	1,46	1390	2,3	2,3	6,6
OMEX-90S4	1,5	85	0,75	5,91	3,40	1,97	1390	2,3	2,3	6,9
OMEX-90L4	2,2	86,4	0,81	7,89	4,54	2,63	1420	2,3	2,3	7,5
OMEX-100L4	3	87,4	0,82	10,51	6,04	3,50	1420	2,3	2,3	7,6
OMEX-112M4	4	88,3	0,82	13,87	7,97	4,62	1430	2,3	2,3	7,7
OMEX-132SA4	5,5	89,2	0,82	18,88	10,85	6,29	1450	2	2,3	7,5
OMEX-132SB4	7,5	90,1	0,83	25,18	14,48	8,39	1450	2	2,3	7,4
OMEX-160MA4	11	91	0,85	35,70	20,53	11,90	1460	2,2	2,3	7,5
OMEX-160MB4	15	91,8	0,86	47,70	27,42	15,90	1460	2,2	2,3	7,5
OMEX-160L4	18,5	92,2	0,86	58,57	33,68	19,52	1470	2,2	2,3	7,7
OMEX-180M4	22	92,6	0,86	69,35	39,88	23,12	1470	2,2	2,3	7,8
OMEX-200LA4	30	93,2	0,86	93,96	54,03	31,32	1470	2,2	2,3	7,2
OMEX-200LB4	37	93,6	0,86	115,39	66,35	38,46	1480	2,2	2,3	7,3
OMEX-225M4	45	93,9	0,86	139,89	80,43	46,63	1480	2,2	2,3	7,4
OMEX-250M4	55	94,2	0,86	170,43	98,00	56,81	1480	2,2	2,3	7,4
OMEX-280S4	75	94,7	0,88	225,92	129,90	75,31	1480	2,2	2,3	6,7
OMEX-280M4	90	95	0,88	270,25	155,39	90,08	1480	2,2	2,3	6,9
OMEX-315S4	110	95,4	0,88	328,92	189,13	109,64	1485	2,2	2,2	6,9
OMEX-315M4	132	95,4	0,88	394,70	226,95	131,57	1485	2,2	2,2	6,9
OMEX-315LA4	160	95,4	0,89	473,05	272,00	157,68	1485	2,2	2,2	6,9
OMEX-315LB4	200	95,4	0,89	591,31	340,00	197,10	1485	2,2	2,2	6,9
OMEX-355MB4	250	95,8	0,9	727,87	418,53	242,62	1490	2,2	2,2	6,9
OMEX-355LB4	315	95,8	0,9	917,12	527,34	305,71	1490	2,2	2,2	6,9

IE2 - 6 Poles

Type	Rated Output (Kw)	100% Load		A Rated current			Rated Speed (rpm)	Ts/Tn	Tmax/Tn	Is/In
		Efficiency %	Power Factor cos	230 V	400 V	690 V				
1000 (r/min)										
OMEX-90S6	0,75	77,7	0,72	3,37	1,94	1,12	910	2,1	2,1	5,8
OMEX-90L6	1,1	79,9	0,73	4,73	2,72	1,58	910	2,1	2,1	5,9
OMEX-100L6	1,5	81,5	0,74	6,24	3,59	2,08	930	2,1	2,1	6
OMEX-112M6	2,2	83,4	0,74	8,95	5,15	2,98	940	2,1	2,1	6
OMEX-132S6	3	84,9	0,74	11,99	6,89	4,00	970	2,1	2,1	6,2
OMEX-132MA6	4	86,1	0,74	15,76	9,06	5,25	970	2	2,1	6,8
OMEX-132MB6	5,5	87,4	0,75	21,06	12,11	7,02	970	2	2,1	7,1
OMEX-160M6	7,5	89	0,78	27,12	15,59	9,04	970	2,1	2,1	6,7
OMEX-160L6	11	90	0,79	38,84	22,33	12,95	970	2,1	2,1	6,9
OMEX-180L6	15	91	0,81	51,08	29,37	17,03	980	2	2,1	7,2
OMEX-200LA6	18,5	91,5	0,81	62,66	36,03	20,89	980	2,1	2,1	7,2
OMEX-200LB6	22	92	0,82	73,21	42,09	24,40	980	2,1	2,1	7,3
OMEX-225M6	30	92,5	0,81	100,51	57,79	33,50	980	2	2,1	7,1
OMEX-250M6	37	93	0,84	118,90	68,36	39,63	980	2,1	2,1	7,1
OMEX-280S6	45	93,5	0,86	140,48	80,78	46,83	980	2,1	2	7,2
OMEX-280M6	55	93,8	0,86	171,15	98,41	57,05	990	2,1	2	7,2
OMEX-315S6	75	94,2	0,85	235,13	135,20	78,38	990	2	2	6,7
OMEX-315M6	90	94,5	0,84	284,61	163,65	94,87	990	2	2	6,7
OMEX-315LA6	110	95	0,85	341,96	196,63	113,99	990	2	2	6,7
OMEX-315LB6	132	95	0,86	405,58	233,21	135,19	990	2	2	6,7
OMEX-355S6	160	95	0,87	485,96	279,43	161,99	995	2	2	6,7
OMEX-355MA6	185	95	0,87	561,89	323,09	187,30	995	2	2	6,7
OMEX-355MB6	200	95	0,87	607,45	349,28	202,48	995	2	2	6,7
OMEX-355L6	250	95	0,87	759,31	436,61	253,10	995	2	2	6,7

Noise

The measured sound power level tested during empty load running of the electric motor should not exceed the values in table 6 and 7 with a tolerance of +3dB(A)

Table 19 (0.12-37KW)

kW Output	r/min synchronous speed			
	3000	1500	1000	750
	dB(A) Sound power			
0.75	67		57	59
1.1		61		
1.5	72		61	61
2.2		64	65	64
3	76		69	
4	77	65		68
5.5	80	71		
7.5			73	
11	86	75		70
15				73
18.5		76	76	
22	88			
30	90	79		75
37		81	78	76

Table 20

(45-315kw)

kW	r/min synchronous speed				
	3000	1500	1000	750	600
	dB(A) Sound power				
45	92	81	80	76	82
55	93	83		82	
75	94	86	85	90	
90					
110	96	93	92	90	
132					
160	98	94	92	—	
(185)					
200	100	95	—	—	
(220)					
250					
(280)					
315					

Vibration

The vibration intensity of RMS tested during the vacuum test should be in conformity with the table below:

Table 21

Mm Centre Height	56 ≤ H ≤ 132			132 < H ≤ 280			225 < H ≤ 400		
	µm Displacement	mm/s Speed	m/s ² accelerated speed	µm Displacement	mm/s Speed	m/s ² accelerated speed	µm Displacement	mm/s Speed	m/s ² accelerated speed
Free mount	25	1.6	2.5	35	2.2	3.5	45	2.8	4.4
Rigid mount	21	1.3	2.0	29	1.8	2.8	37	2.3	3.6

1. Values in the table are A level
2. Interface frequency for Displacement/speed is 10Hz, and 250 Hz for Speed/accelerated speed

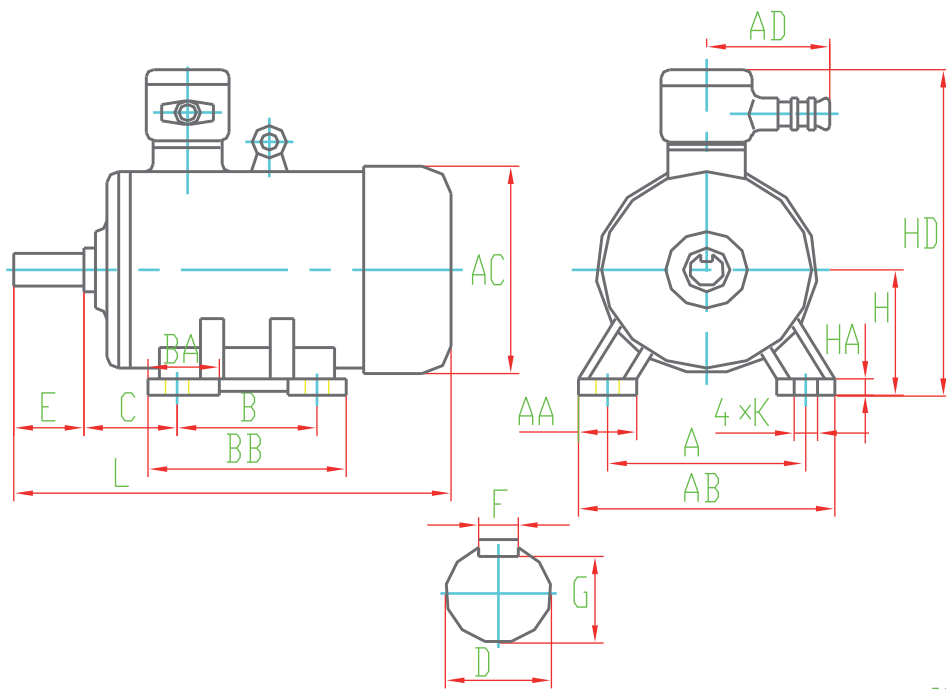

IMB3

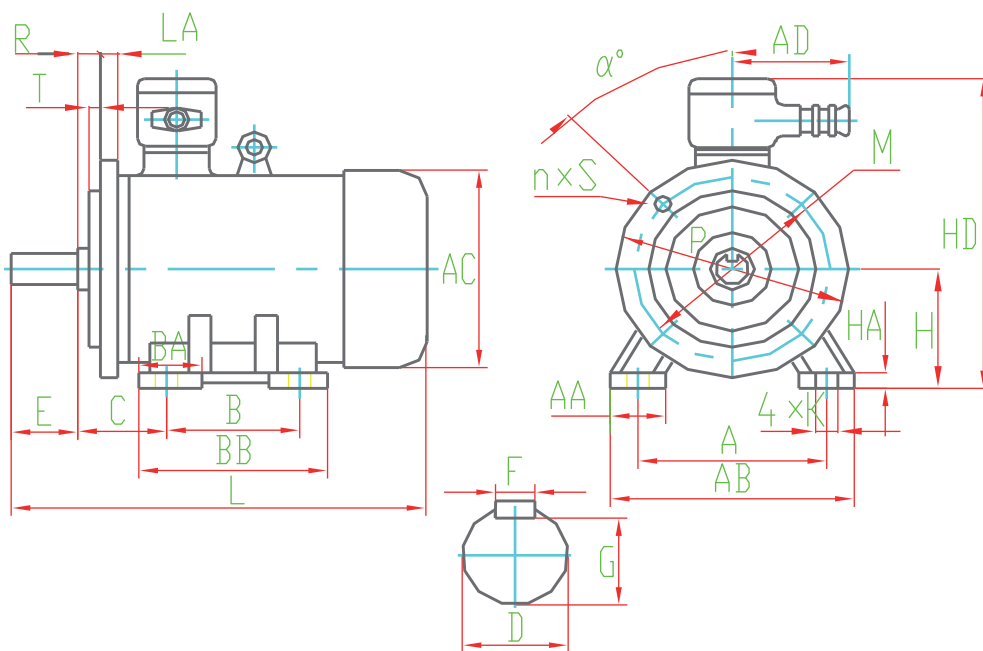

IMB35

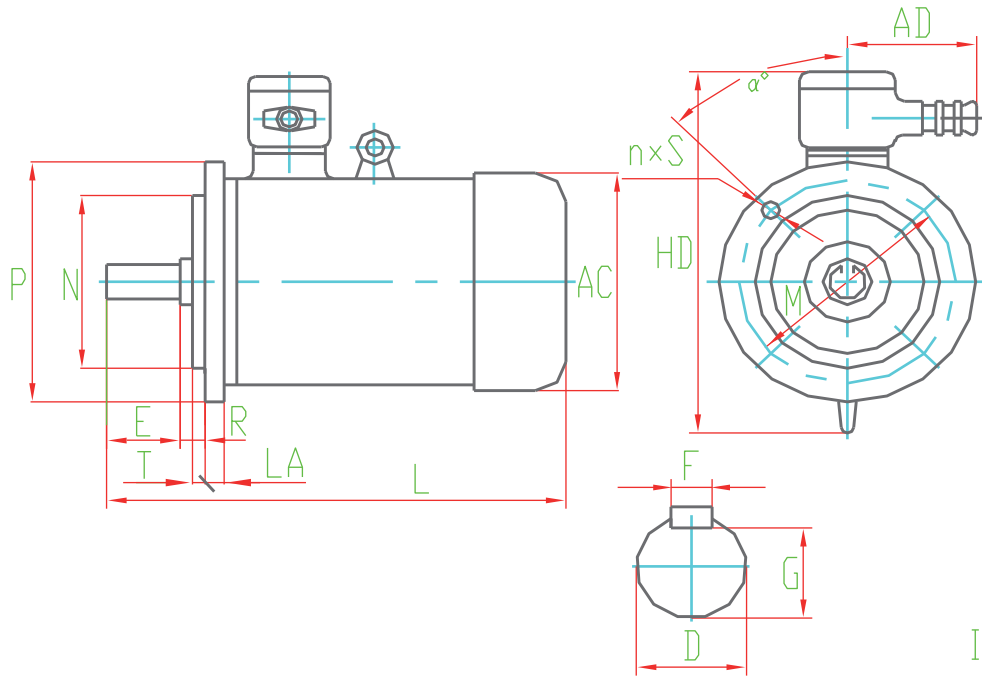

IMB5

Table 22

Frame size	Mounting dimension												
	A	B	C	C		E		F		G		H	K
				2P	4P and above	2P	4P and above	2P	4P and above	2P	4P and above		
63	100	80	40	11		23		4		8,5		63	7
71	112	90	45	14		30		5		11		71	10
80	125	100	50	19		40		6		15,5		80	10
90S			56	24		50		8		20		90	10
90L												10	
100L	160	140	63	28		60				24		100	12
112M	190	140	70	28		60		8		24		112	12
132S	216	140	89	38		60		10		33		132	12
132M	216	178	89	38		60		10		33		132	12
160M	254	210	108	42		110		12		37		160	15
160L	254	254	108	42		110		12		37		160	15
180M	279	241	121	48		110		14		42,5		180	15
180L	279	279	121	48		110		14		42,5		180	15
200L	318	305	133	55		110		16		49		200	19
225S	356	286	149	55	60	110	140	16	18	49	53	225	19
225M	356	311	149	55	60	110	140	16	18	49	53	225	19
250M	406	349	168	60	65	140	140	18	18	53	58	250	24
280S	457	368	190	65	75	140	140	18	20	58	67,5	280	24
280M	457	419	190	65	75	140	140	18	20	58	67,5	280	24
315S	508	406	216	65	80	140	170	18	22	58	71	315	28
315M	508	457	216	65	80	140	170	18	22	58	71	315	28
315L	508	508	216	65	80	140	170	18	22	58	71	315	28
355S	610	500	254	75	95	140	170	20	25	67,5	86	355	28
355M	610	560	254	75	95	140	170	20	25	67,5	86	355	28
355L	610	630	254	75	95	140	170	20	25	67,5	86	355	28

Mounting dimension																
	Flange dimension							AA	AB	AC	AD	BB	HA	HD	L	
	M	N	P	R	a	T	nXs								2P	4P and above
	115	95	140	0	45	3	4x10	25	130	150	165	110	8	230	245	245
	130	110	160	0	45	3,5	4x12	28	140	155		114	8	250	275	275
	165	130	200	0	45	4	4x14,5	34	165	165	180	130	10	320	330	330
								36	180	180		130	14	350	360	360
								36				155	14		385	385
	215	180	250	0	45	4	4x14,5	40	200	215	200	175	14	385	450	450
	215	180	250	0	45	4	4x14,5	50	240	215	200	185	16	390	450	450
	265	230	300	0	45	4	4x14,5	60	280	270	225	200	17	430	535	535
	265	230	300	0	45	4	4x14,5	60	280	270	225	238	17	430	570	570
	300	250	350	0	45	5	4x18,5	75	325	325	225	270	20	485	680	680
	300	250	350	0	45	5	4x18,5	75	325	325	225	315	20	485	730	730
	300	250	350	0	45	5	4x18,5	80	349	360	225	310	22	520	765	765
	300	250	350	0	45	5	4x18,5	80	349	360	225	345	22	520	785	785
	350	300	400	0	45	5	4x18,5	85	390	400	250	375	25	600	840	840
	400	350	450	0	23	5	4x18,5	90	435	450	250	370	28	640	830	865
	400	350	450	0	22.5	5	4x18,5	90	435	450	250	383	28	640	865	895
	500	450	550	0	22.5	5	4x18,5	95	480	500	300	425	30	720	965	965
	500	450	550	0	22.5	5	4x18,5	100	540	535	300	450	35	780	1050	1050
	500	450	550	0	22.5	5	4x18,5	100	540	535	300	490	35	780	1120	1120
	600	550	660	0	22.5	6	4x24	132	580	630	370	540	40	910	1280	1310
	600	550	660	0	22.5	6	4x24	132	580	630	370	590	40	910	1310	1350
	600	550	660	0	22.5	6	4x24	132	580	630	370	640	40	910	1450	1480
	740	680	800	0	22.5	6	4x24	140	740	750	370	710	40	990	1530	1590
	740	680	800	0	22.5	6	4x24	140	740	750	370	770	42	990	1610	1670
	740	680	800	0	22.5	6	4x24	140	740	750	370	840	42	990	1710	1770

Purchase guide

Information in this catalogue may change in accordance to technical development, please check the published date.

If there are special requirements such as special voltage, frequency, IP protection, direction of rotation, double shaft end, noise limits and others, a technical agreement must be signed before manufacturing begins.

Electric motor type, Pole, output, voltage, frequency, insulation level, structure and mounting method, explosion-proof markings must be stated out clearly.

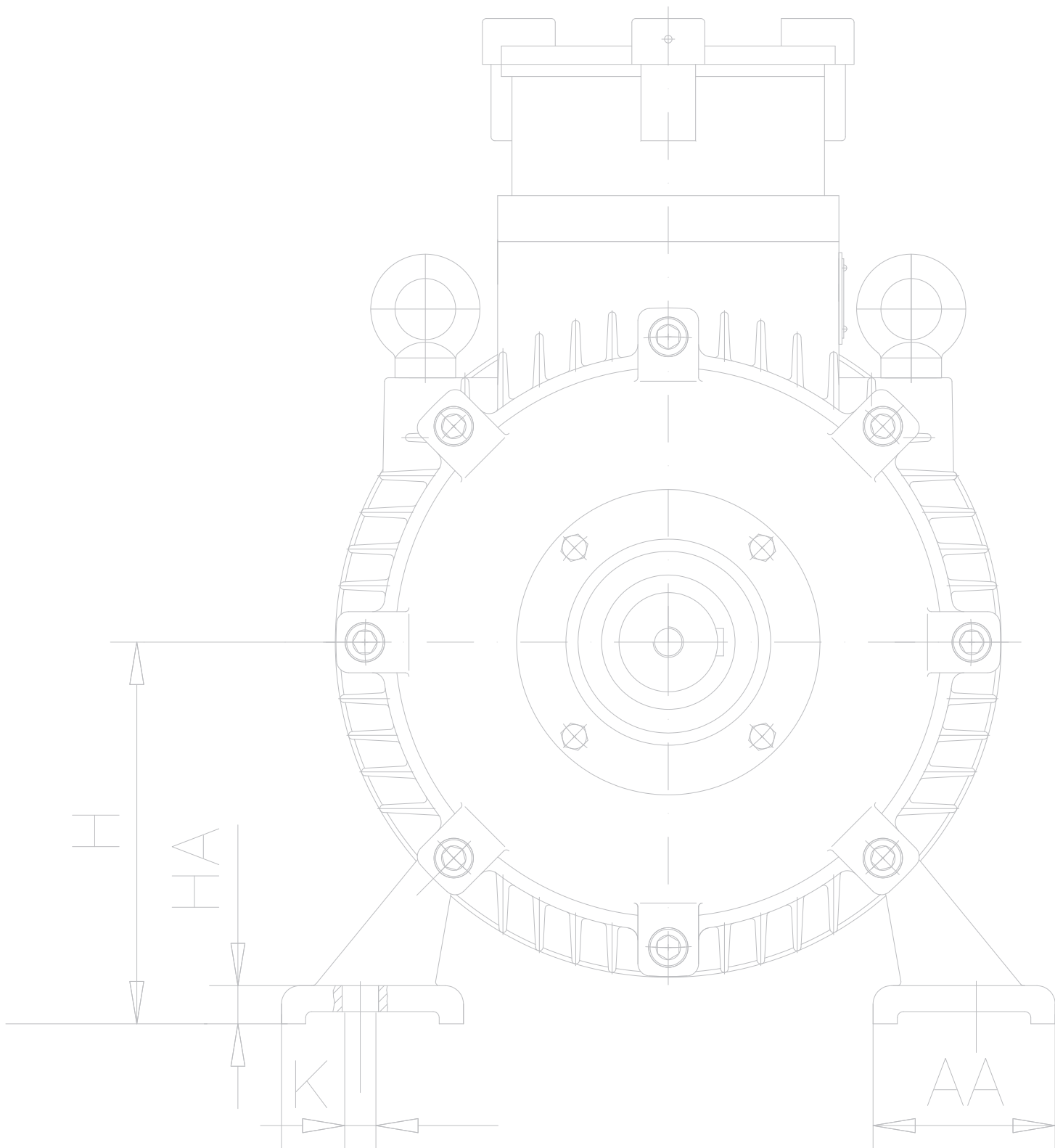

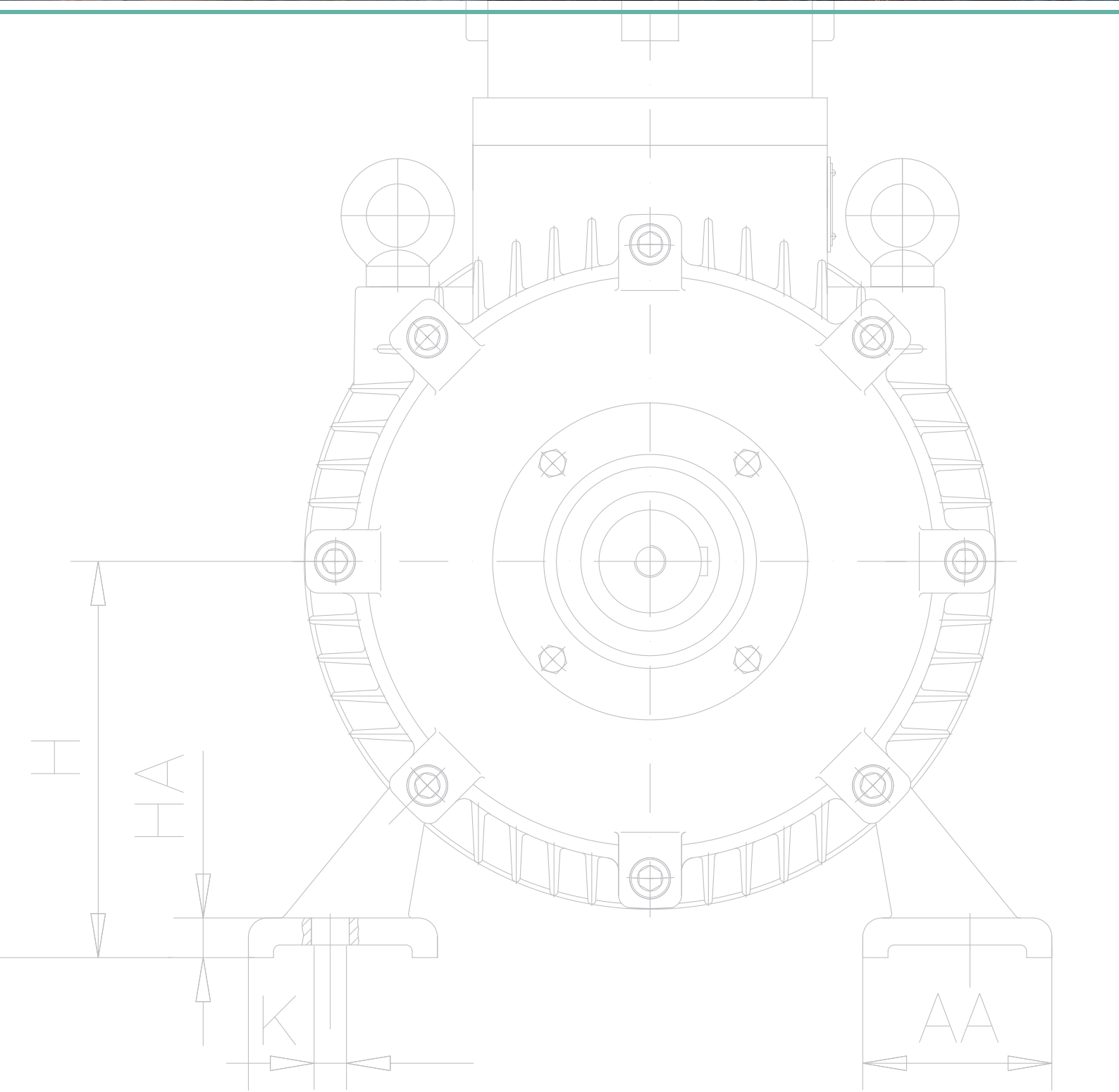

OME Electric Motors S.r.l.
Via Niccolò Tartaglia n.6/b - 25064 Gussago (BS) - Italy

☎ +39 030 317063 +39 030 3737072

📠 +39 030 2411395

✉ info@omemotors.com

🌐 www.omemotors.com