



T MACHINERY

CZECH REPUBLIC

T Machinery a.s. is one of the important production/engineering companies in the area of mining technology and at the same time the only producer in the Czech Republic which is able to design, produce, deliver and put into operation the whole mining complex. Historically, the company picked up the threads of traditional production in this area that have existed in the South Moravia for more than 80 years. The mine Tomáš was established for mechanized lignite mining for power needs of the concern company "BAŤA" in the 1930's.

T Machinery a. s. fulfils two basic strategic targets:

- Production innovation in the area of mining machinery
- Maximization of success of the produced technologies, particularly in foreign markets

The company production program:

Production of the company is directed at excavating mining complexes in coal, underground mines that consist of the following technology:

Development and production of MB series shearers, armored face conveyors with different height of E-profile, power roof supports in order to secure mining space including their control and other under-face devices. T Machiner, a.s. provides a comprehensive service and training activity, production of spare parts, all electrical accessories and regulation of automated mining.

Corporate culture of the company is based upon professionalism, expertness and team work of top specialists. These pre-conditions form a significant development potential and dynamics of the company. No success would be possible without professional knowledge and experience of our employees. Top quality and loyal employees are considered to be the main source of success for T Machinery, a.s.

Export activities of the company T Machinery, a.s. are currently directed at complete deliveries of mining machinery and they are important potential of further development of the company. The company's largest export share is in Ukrainian and Russian markets, but it also sells machines and machinery e.g. to Vietnam. Company activities involve complex of services, designing, engineering and servicing. Important competitive advantage of the company is its ability to realize complex projects with provision of individual demands and requirements of customers. Experience of T Machinery, a.s. is at appropriate level for almost all mining options.

T Machinery's, a.s. team of experts still intensively **develops** new machines that comply with world's criteria. In order to maximize increase in efficiency and minimize physical work to eliminate the negative influence of human factor on operation, which always brings higher safety during performance of all mining activities. The company's main interest is to continue in 80 year long tradition of quality mining machinery production in the South Moravia.

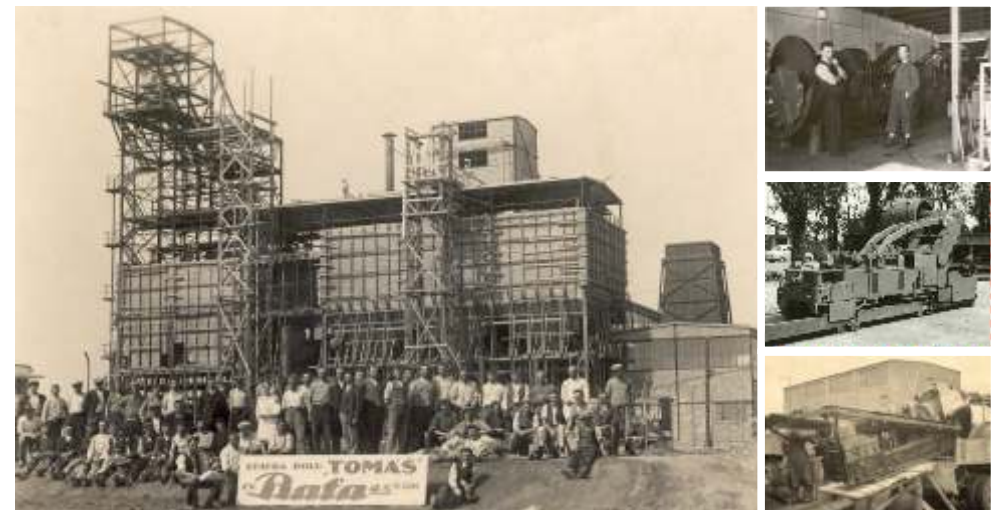
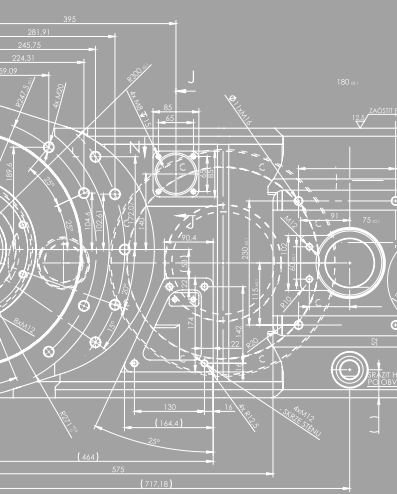

Batovka 1285
696 02 Ratíškovice
Česká republika

+420 518 391 511 [CS]
+420 518 391 607 [RU]
+420 518 391 526 [EN]
+420 518 391 590 [DE]
export@tmachinery.cz

WWW.TMACHINERY.CZ



CONTENT

About us	1
Content	2
Shearers	3
MB 12 (MB 612E, MB 712E, MB 812E)	4
MB 12 compact (MB 320E, MB 450E)	5
MB 13 (MB 444P)	6
MB 13 (MB 510P)	7
MB 14 (MB 280E)	8
MB 14 (MB 410E)	9
MB 14 (MB 410E/ZK) 1/2	10
MB 14 (MB 410E/ZK) 2/2	11
MB 14 (MB 470E)	12
MB 14 (MB 630E)	13
MB 14 (MB 750E)	14
MB 14 Ei (MB 430Ei)	15
MB 14 Ei (MB 720Ei)	16
MB 15 (MB 850E, 1200ESG)	17
MB 900CM	18
MB 16 (MB 330 MONO) 1/2	19
MB 16 (MB 330 MONO) 2/2	20
MB 260 LM 1/2	21
MB 260 LM 2/2	22
TM Vizualization 1/2	23
TM Vizualization 2/2	24
Powered roof supports	25
MVPO 800	26
MVPO 2800	27
MVPO 3200	28
MVPO 3200X	29
MVPO 4200	30
MVPO 5600	31
Armored face conveyors	32
HD 190	33
HD 228 1/2	34
HD 228 2/2	35
HD 260	36
HD 284	37
HD 228/732U	38
Possibility of connections	39
Switching power systems	40
APK9U 1/2	41
APK9U 2/2	42
MFK 400.SNO 1/2	43
MFK 400.SNO 2/2	44
TPK9S.XXX 1/2	45
TPK9S.XXX 2/2	46
UNDER FACE DEVICES	47
Stage loader 1/2	48
Stage loader 2/2	49
Others	50
TM KUU	51
TM KUO	52
Coal crusher 1/2	53
Coal crusher 2/2	54
Anchorage of the face conveyors	55
Belt transport in underground mines	56
Mine trailer locomotive BIZON	60
Mobile power station	61
Testing room 1/2	62
Testing room 2/2	63

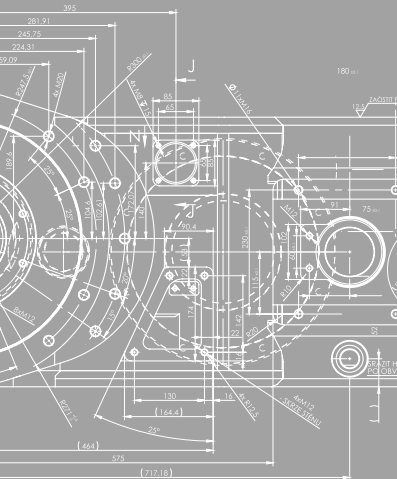

Batovka 1285
696 02 Ratíškovice
Česká republika

+420 518 391 511 [CS]
+420 518 391 607 [RU]
+420 518 391 526 [EN]
+420 518 391 590 [DE]
export@tmachinery.cz

WWW.TMACHINERY.CZ



T MACHINERY
CZECH REPUBLIC



T Machinery a.s. produces shearers for bi-directional and unidirectional mining of deposits of coal and some other minerals in the form of seams. Shearers are primarily designed for coal mining, but also for mining of salt, oil-bearing shale and other minerals. The shearers are manufactured in accordance with the requirements of Directive 2014/34/EU (ATEX) and in accordance with the equivalent directives of the Russian Federation and Ukraine.

The shearers, according to our own, 50 years proven design, are produced in several series, according to the thickness mined. Each shearer is designed to meet specific customer requirements. MB series shearers resist the toughest mining and geological conditions, with an ever-efficient mining performance, which has proven and continues to prove in the mines in Russia and Ukraine.



SHEARERS

T Machinery a.s ensures the highest quality and durability of these highly variable mining machines by production in our own production plant in the Czech Republic.

Where other engineering companies have abandoned the development of shearers intended for small thicknesses, T Machinery company has developed a new line of MB machines for the toughest conditions. New portal version of shearers can achieve mining outputs of up to three thousand tons per day in a seam thickness of only 0.8-1 m. This means that T Machinery changes the economically uninteresting deposits to mineable and profitable deposits.

The shearers are equipped with powerful drives and picking organs, powered by world-class electric motors. The power supply and control of the feed rate of the shearer, depending on the strength and the momentary conditions of the mined seam, are solved by the frequency converter with the transformer, also developed and manufactured by T Machinery. Upon request of the customer, the shearers can be fitted with elements to increase of abrasion resistance.

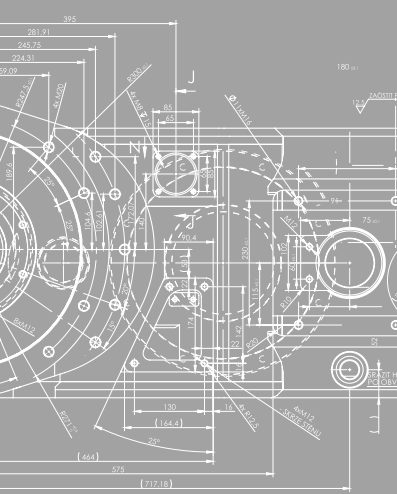

Batovka 1285
696 02 Ratíškovice
Česká republika

+420 518 391 511 [CS]
+420 518 391 607 [RU]
+420 518 391 526 [EN]
+420 518 391 590 [DE]
export@tmachinery.cz

WWW.TMACHINERY.CZ



T MACHINERY
CZECH REPUBLIC

SHEARERS

MB 12 SERIES

Seam thickness: 1.8 - 5.2 m
Performance: 29 - 40 t/min
Total output: 612 - 812 kW
Operating voltage: 1140/660 V

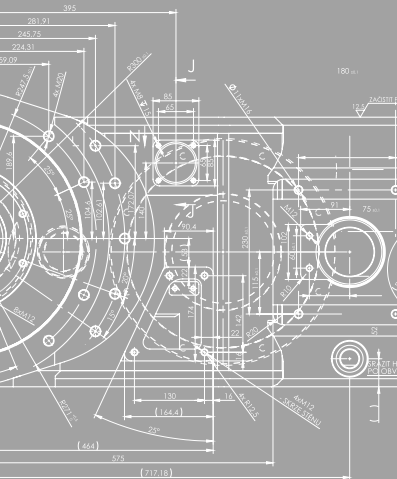

Technical parameters	MB 612E	MB 712E	MB 812E
Length	11 200	11 200	12 000 mm
Drum diameter	1 600 - 2 000	1 600 - 2 250	1 800 - 2 500 mm
Seam thickness	1.8 - 4.0	2.5 - 4.5	2.5 - 5.2 m
Performance*	29	37	40 t/min.
The height of shearer from the floor**	1 146	2 032	2 032 mm
Drum RPM	33 - 47	33 - 40	30 - 35 r/min.
Drum width	630 - 800	630 - 800	630 - 800 mm
Face gradient-lingitudinal	± 35	± 35	± 35 °
Face gradient-laterall	± 20	± 20	± 20 °
Drum cutting under the conveyor	200 - 300	150 - 250	330 mm
Haulage speed	0 - 15	0 - 15	0 - 13 m/min.
Haulage pull	2 x 330	2 x 400	2 x 400 kN
Total output of motors	612	712	812 kW
Cutting motor power	2 x 250	2 x 300	2 x 350 kW
Haulage motor power	2 x 45	2 x 45	2 x 45 kW
Hydraulic motor power	1 x 22	1 x 22	1 x 22 kW
Lumpbreaker motor power	-	-	-
Operating voltage	1 140/660	1 140/660	1 140/660 V
Weight	41	47.5	50 t

*the coal strength max. 360 kN/m **depending on the conveyor

Batovka 1285
696 02 Ratíškovice
Česká republika

+420 518 391 511 [CS]
+420 518 391 607 [RU]
+420 518 391 526 [EN]
+420 518 391 590 [DE]
export@tmachinery.cz

WWW.TMACHINERY.CZ



T MACHINERY
CZECH REPUBLIC

SHEARERS

MB 12 COMPACT SERIES

Seam thickness: 1.0 - 2.5 m
Performance: 10 - 17 t/min
Total output: 320 - 450 kW
Operating voltage: 1140/660 V

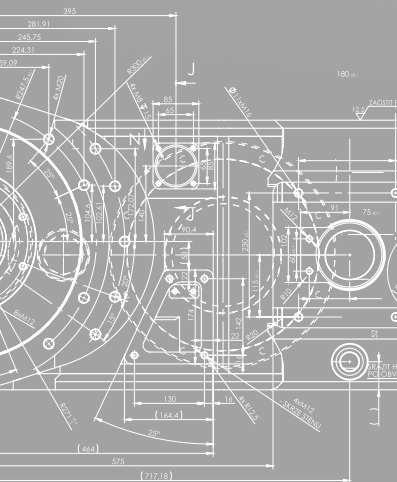

Technical parameters	MB 320E	MB 450E
Length	7 767	7 800 mm
Drum diameter	950 - 1 250	1 000 - 1 500 mm
Seam thickness	1 - 2.3	1.0 - 2.6 m
Performance*	10	14 - 17 t/min.
The height of shearer from the floor**	801	801 mm
Drum RPM	46 - 57	45 - 58 r/min.
Drum width	630 - 800	630 - 800 mm
Face gradient-lingitudinal	± 35	± 35 °
Face gradient-laterall	± 25	± 25 °
Drum cutting under the conveyor	150 - 250	150 - 250 mm
Haulage speed	0 - 11.5	0 - 11.5 m/min.
Haulage pull	2 x 220	2 x 200 kN
Total output of motors	321.5	451.5 kW
Cutting motor power	2 x 135	2 x 200 kW
Haulage motor power	2 x 22	2 x 22 kW
Hydraulic motor power	1 x 7.5	1 x 7.5 kW
Lumpbreaker motor power	-	-
Operating voltage	660 (500) / 1 140 (1 000) V	
Weight	18	19 t

*the coal strength max. 360 kN/m **depending on the conveyor

Batovka 1285
696 02 Ratíškovice
Česká republika

+420 518 391 511 [CS]
+420 518 391 607 [RU]
+420 518 391 526 [EN]
+420 518 391 590 [DE]
export@tmachinery.cz

WWW.TMACHINERY.CZ



T MACHINERY
CZECH REPUBLIC

SHEARER MB 13 SERIES

Seam thickness: 0.88 - 1.3 m
Performance: 6 - 7 t/min
Total output: 444 - 510 kW
Operating voltage: 1140/660 V

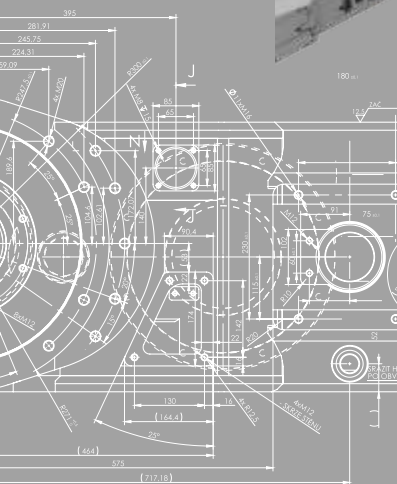
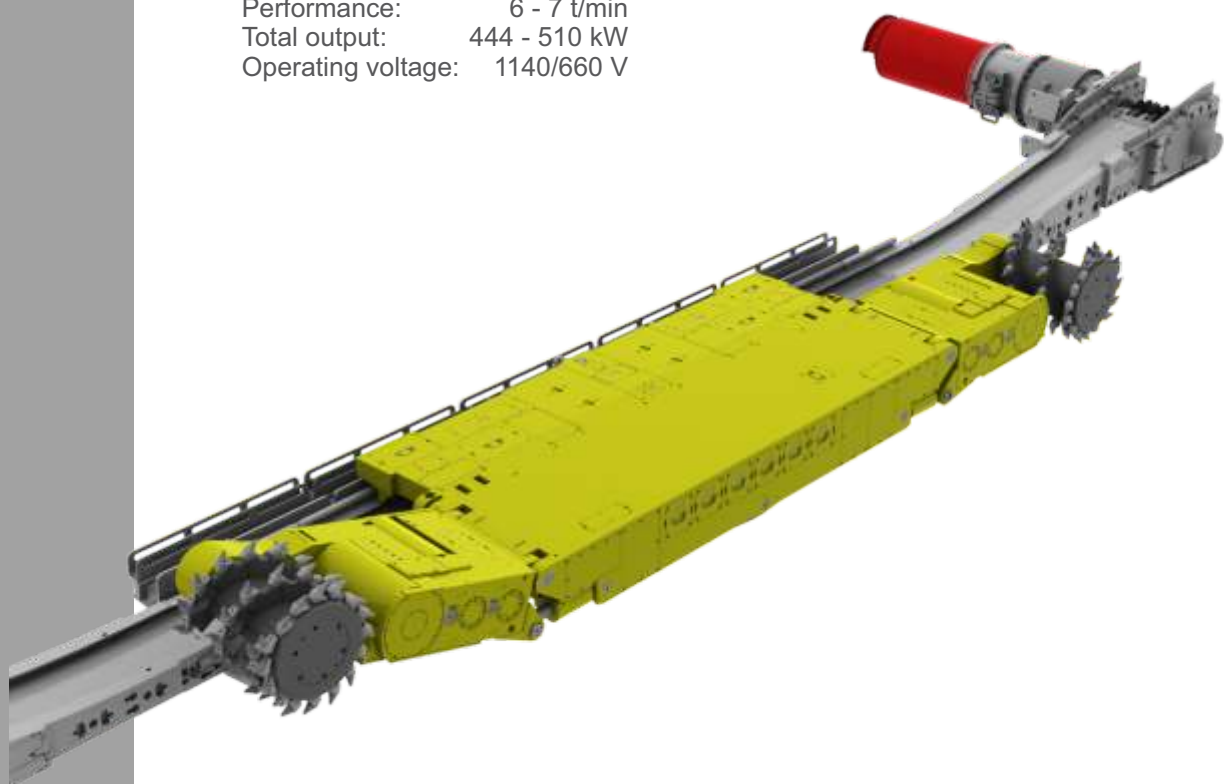

Technical parameters	MB 444P
Length	8 265 mm
Drum diameter	700 - 900 mm
Seam thickness	0.88 - 1.3 m
Performance*	6 - 7 t/min.
The height of shearer from the floor**	620 mm
Drum RPM	78 r/min.
Drum width	800 mm
Face gradient-lingitudinal	± 35 °
Face gradient-laterall	± 20 °
Drum cutting under the conveyor	150 mm
Haulage speed	0 - 11.5 m/min.
Haulage pull	2 x 200 kN
Total output of motors	444 kW
Cutting motor power	2 x 200 kW
Haulage motor power	2 x 22 kW
Hydraulic motor power	- kW
Lumpbreaker motor power	-
Operating voltage	1 140/660 V
Weight	22 t

Batovka 1285
696 02 Ratíškovice
Česká republika

+420 518 391 511 [CS]
+420 518 391 607 [RU]
+420 518 391 526 [EN]
+420 518 391 590 [DE]
export@tmachinery.cz

WWW.TMACHINERY.CZ

*the coal strength max. 360 kN/m **depending on the conveyor



T MACHINERY
CZECH REPUBLIC

SHEARER MB 13 SERIES

Seam thickness: 0.88 - 1.3 m
Performance: 6 - 7 t/min
Total output: 444 - 510 kW
Operating voltage: 1140/660 V

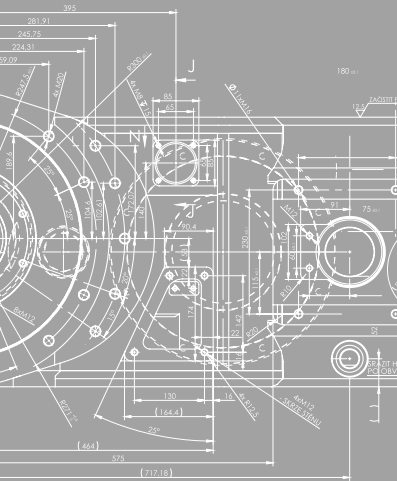

Technical parameters	MB 510P
Length	8 390 mm
Drum diameter	700 - 900 mm
Seam thickness	0.8 - 1.3 m
Performance*	8 t/min.
The height of shearer from the floor**	620 mm
Drum RPM	84 r/min.
Drum width	800 mm
Face gradient-lingitudinal	$\pm 35^\circ$
Face gradient-laterall	$\pm 20^\circ$
Drum cutting under the conveyor	150 mm
Haulage speed	0 - 11,5 m/min.
Haulage pull	2 x 300 kN
Total output of motors	507.5 kW
Cutting motor power	2 x 220 kW
Haulage motor power	2 x 32 kW
Hydraulic motor power	7.5 kW
Lumpbreaker motor power	-
Operating voltage	1 140/660 V
Weight	24 t

*the coal strength max. 360 kN/m **depending on the conveyor

Batovka 1285
696 02 Ratíškovice
Česká republika

+420 518 391 511 [CS]
+420 518 391 607 [RU]
+420 518 391 526 [EN]
+420 518 391 590 [DE]
export@tmachinery.cz

WWW.TMACHINERY.CZ



T MACHINERY
CZECH REPUBLIC

SHEARER

MB 14 SERIES

Seam thickness: 0.8 - 3.0 m
Performance: 5 - 32 t/min
Total output: 280 - 630 kW
Operating voltage: 1140/660 V

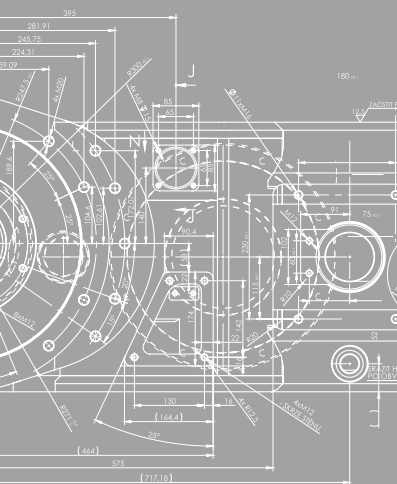

Technical parameters	MB 280E
Length	7 270 mm
Drum diameter	750 - 900 mm
Seam thickness	0.8 - 1.6 m
Performance*	5 - 6 t/min.
The height of shearer from the floor**	680 mm
Drum RPM	78 r/min.
Drum width	800 mm
Face gradient-lingitudinal	± 35 °
Face gradient-laterall	± 20 °
Drum cutting under the conveyor	150 mm
Haulage speed	0 - 11,5 m/min.
Haulage pull	2 x 160 kN
Total output of motors	279.5 kW
Cutting motor power	2 x 125 kW
Haulage motor power	2 x 16 kW
Hydraulic motor power	7.5 kW
Lumpbreaker motor power	-
Operating voltage	1 140/660 V
Weight	14 t

Batovka 1285
696 02 Ratíškovice
Česká republika

+420 518 391 511 [CS]
+420 518 391 607 [RU]
+420 518 391 526 [EN]
+420 518 391 590 [DE]
export@tmachinery.cz

WWW.TMACHINERY.CZ

*the coal strength max. 360 kN/m **depending on the conveyor



T MACHINERY
CZECH REPUBLIC

SHEARER MB 14 SERIES

Seam thickness: 0.8 - 3.0 m
Performance: 5 - 32 t/min
Total output: 80 - 630 kW
Operating voltage: 1140/660 V

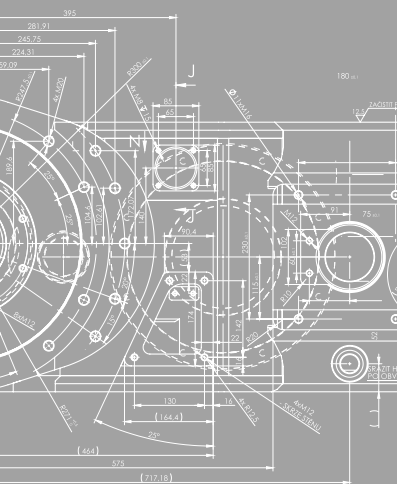

Technical parameters	MB 410E
Length	8 220 mm
Drum diameter	800 - 1 000 mm
Seam thickness	0.9 - 1.8 m
Performance*	6 - 9 t/min.
The height of shearer from the floor**	717 mm
Drum RPM	63 r/min.
Drum width	800 mm
Face gradient-lingitudinal	± 35 °
Face gradient-laterall	± 20 °
Drum cutting under the conveyor	150 mm
Haulage speed	0 - 12 m/min.
Haulage pull	2 x 220 kN
Total output of motors	411.5 kW
Cutting motor power	2 x 180 kW
Haulage motor power	2 x 22 kW
Hydraulic motor power	7.5 kW
Lumpbreaker motor power	-
Operating voltage	1 140/660 V
Weight	18 t

Batovka 1285
696 02 Ratíškovice
Česká republika

+420 518 391 511 [CS]
+420 518 391 607 [RU]
+420 518 391 526 [EN]
+420 518 391 590 [DE]
export@tmachinery.cz

WWW.TMACHINERY.CZ

*the coal strength max. 360 kN/m **depending on the conveyor



T MACHINERY
CZECH REPUBLIC

SHEARER MB 14 SERIES

Seam thickness: 0.8 - 3.0 m
Performance: 5 - 32 t/min
Total output: 280 - 630 kW
Operating voltage: 1140/660 V

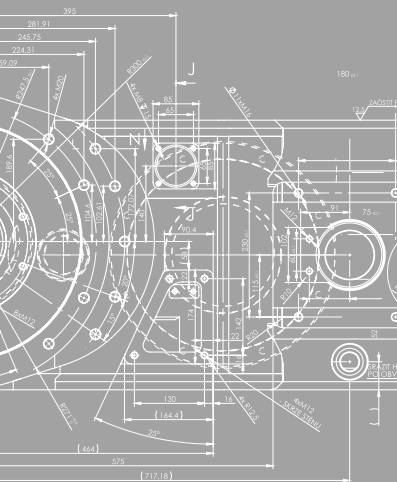
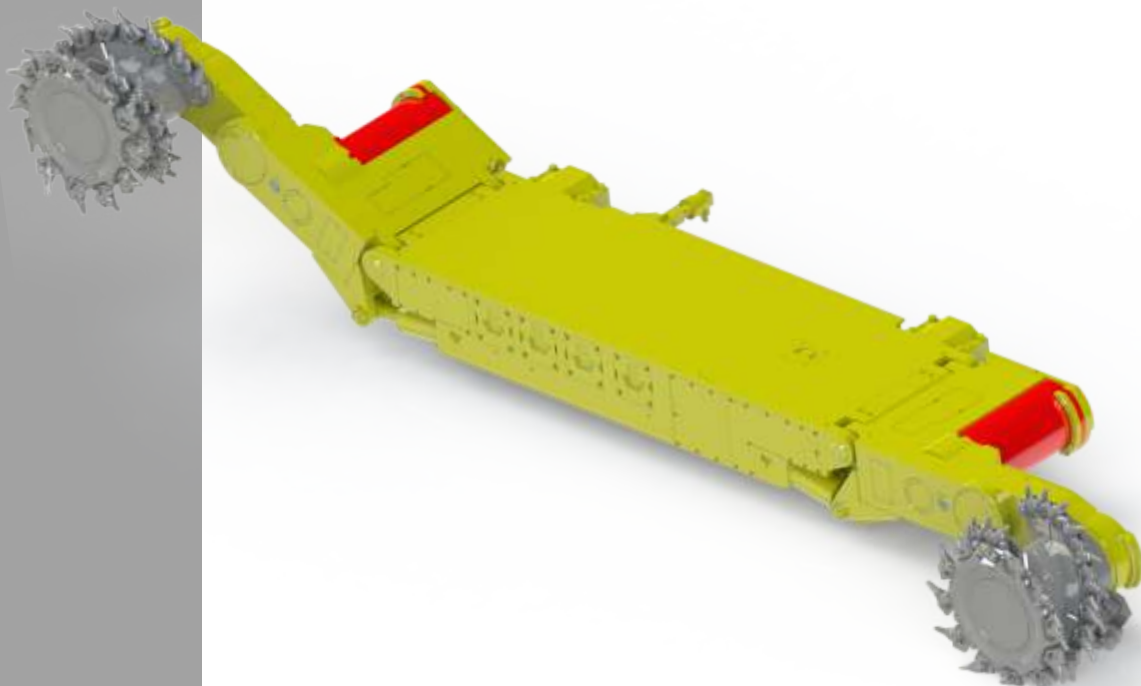

Technical parameters	MB 410E/ZK
Length	7 181 mm
Drum diameter	800 - 1 000 mm
Seam thickness	0.9 - 1.6 m
Performance*	6 - 9 t/min.
The height of shearer from the floor**	717 mm
Drum RPM	63 r/min.
Drum width	800 mm
Face gradient-lingitudinal	$\pm 35^\circ$
Face gradient-laterall	$\pm 20^\circ$
Drum cutting under the conveyor	150 mm
Haulage speed	0 - 12 m/min.
Haulage pull	2 x 220 kN
Total output of motors	411.5 kW
Cutting motor power	2 x 180 kW
Haulage motor power	2 x 22 kW
Hydraulic motor power	7.5 kW
Lumpbreaker motor power	-
Operating voltage	1 140/660 V
Weight	16.5 t

*the coal strength max. 360 kN/m **depending on the conveyor

Batovka 1285
696 02 Ratíškovice
Česká republika

+420 518 391 511 [CS]
+420 518 391 607 [RU]
+420 518 391 526 [EN]
+420 518 391 590 [DE]
export@tmachinery.cz

WWW.TMACHINERY.CZ



T MACHINERY
CZECH REPUBLIC

SHEARER MB 14 SERIES

Seam thickness: 0.8 - 3.0 m
Performance: 5 - 32 t/min
Total output: 280 - 630 kW
Operating voltage: 1140/660 V

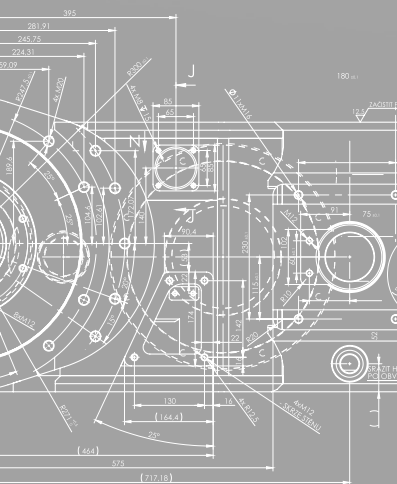

Technical parameters	MB 470E
Length	8 830 mm
Drum diameter	1 000 - 1 500 mm
Seam thickness	1.0 - 2.6 m
Performance*	15 - 18 t/min.
The height of shearer from the floor**	775 mm
Drum RPM	45 - 58 r/min.
Drum width	630 - 800 mm
Face gradient-lingitudinal	± 35 °
Face gradient-laterall	± 20 °
Drum cutting under the conveyor	150 mm
Haulage speed	0 - 12 m/min.
Haulage pull	2 x 250 kN
Total output of motors	467.5 kW
Cutting motor power	2 x 200 kW
Haulage motor power	2 x 30 kW
Hydraulic motor power	7.5 kW
Lumpbreaker motor power	-
Operating voltage	1 140/660 V
Weight	20.5 t

*the coal strength max. 360 kN/m **depending on the conveyor

Batovka 1285
696 02 Ratíškovice
Česká republika

+420 518 391 511 [CS]
+420 518 391 607 [RU]
+420 518 391 526 [EN]
+420 518 391 590 [DE]
export@tmachinery.cz

WWW.TMACHINERY.CZ



T MACHINERY
CZECH REPUBLIC

SHEARER MB 14 SERIES

Seam thickness: 0.8 - 3.0 m
Performance: 5 - 32 t/min
Total output: 280 - 630 kW
Operating voltage: 1140/660 V

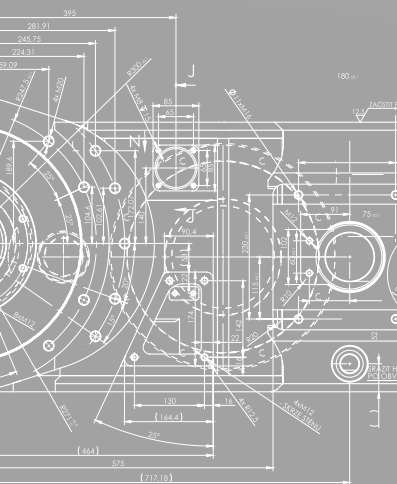

Batovka 1285
696 02 Ratíškovice
Česká republika

+420 518 391 511 [CS]
+420 518 391 607 [RU]
+420 518 391 526 [EN]
+420 518 391 590 [DE]
export@tmachinery.cz

WWW.TMACHINERY.CZ

Technical parameters	MB 630E
Length	9 825 mm
Drum diameter	1 000 - 1 500 mm
Seam thickness	1.0 - 3.0 m
Performance*	5 - 32 t/min.
The height of shearer from the floor**	797 mm
Drum RPM	49 r/min.
Drum width	800 mm
Face gradient-longitudinal	± 35 °
Face gradient-laterall	± 20 °
Drum cutting under the conveyor	200 mm
Haulage speed	0 - 11.5 m/min.
Haulage pull	2 x 300 kN
Total output of motors	627.5 kW
Cutting motor power	2 x 280 kW
Haulage motor power	2 x 30 kW
Hydraulic motor power	7.5 kW
Lumpbreaker motor power	-
Operating voltage	1 140(1 000)/660(500) V
Weight	32 t

*the coal strength max. 360 kN/m **depending on the conveyor



T MACHINERY
CZECH REPUBLIC

SHEARER MB 14 SERIES

Seam thickness: 0.8 - 3.0 m
Performance: 5 - 32 t/min
Total output: 280 - 630 kW
Operating voltage: 1140/660 V

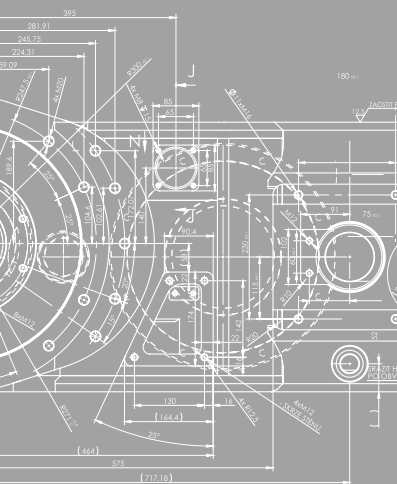

Technical parameters	MB 750E
Length	13 240 mm
Drum diameter	1 400 - 2 000 mm
Seam thickness	1.4 - 4.1 m
Performance*	35 t/min.
The height of shearer from the floor**	1 200 mm
Drum RPM	33 - 48 r/min.
Drum width	800 - 850 mm
Face gradient-longitudinal	± 35 °
Face gradient-laterall	± 20 °
Drum cutting under the conveyor	300 mm
Haulage speed	0 - 20 m/min.
Haulage pull	2 x 340 kN
Total output of motors	742 kW
Cutting motor power	2 x 300 kW
Haulage motor power	2 x 60 kW
Hydraulic motor power	22 kW
Lumpbreaker motor power	-
Operating voltage	1 140(3 300)/660 V
Weight	70 t

*the coal strength max. 360 kN/m **depending on the conveyor

Batovka 1285
696 02 Ratíškovice
Česká republika

+420 518 391 511 [CS]
+420 518 391 607 [RU]
+420 518 391 526 [EN]
+420 518 391 590 [DE]
export@tmachinery.cz

WWW.TMACHINERY.CZ



T MACHINERY
CZECH REPUBLIC

SHEARER MB 14 Ei SERIES

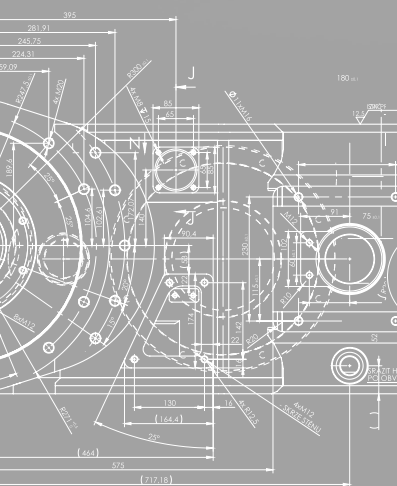

Technical parameters	MB 430Ei
Length	8 216 mm
Drum diameter	0.8 - 1.1 m
Seam thickness	0.9 - 2.2 m
Performance*	14 t/min.
The height of shearer from the floor**	731 mm
Drum RPM	63 r/min.
Drum width	800 mm
Face gradient-lingitudinal	± 35 °
Face gradient-laterall	± 20 °
Drum cutting under the conveyor	150 mm
Haulage speed	0 - 12.9 - 17.2 m/min.
Haulage pull	2 x 302 kN
Total output of motors	427.5 kW
Cutting motor power	2 x 180 kW
Haulage motor power	2 x 30 kW
Hydraulic motor power	1 x 7.5 kW
Lumpbreaker motor power	-
Operating voltage	1 140/660 V
Weight	18 t

*the coal strength max. 360 kN/m **depending on the conveyor

Batovka 1285
696 02 Ratíškovice
Česká republika

+420 518 391 511 [CS]
+420 518 391 607 [RU]
+420 518 391 526 [EN]
+420 518 391 590 [DE]
export@tmachinery.cz

WWW.TMACHINERY.CZ



T MACHINERY
CZECH REPUBLIC

SHEARER MB 14 Ei SERIES

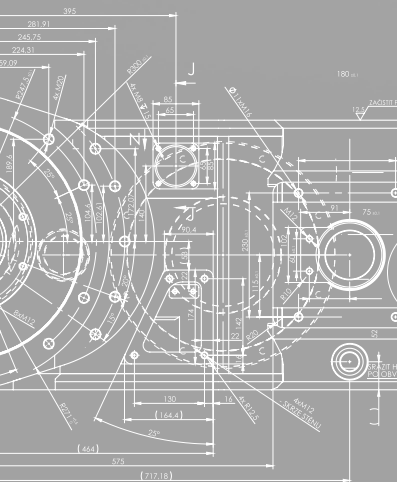

Technical parameters	MB 720Ei
Length	10 600 mm
Drum diameter	1.2 - 1.8 (2.0) m
Seam thickness	1.25 - 4.0 (4.4) m
Performance*	30 t/min.
The height of shearer from the floor**	797 mm
Drum RPM	35 - 56 ot/min.
Drum width	800 mm
Face gradient-lingitudinal	$\pm 35^\circ$
Face gradient-laterall	$\pm 20^\circ$
Drum cutting under the conveyor	250 mm
Haulage speed	0 - 16 - 21.3 m/min.
Haulage pull	2 x 407 kN
Total output of motors	716 kW
Cutting motor power	2 x 300 kW
Haulage motor power	2 x 50 kW
Hydraulic motor power	1 x 16 kW
Lumpbreaker motor power	-
Operating voltage	1 140/660 V
Weight	41 t

*the coal strength max. 360 kN/m **depending on the conveyor

Batovka 1285
696 02 Ratíškovice
Česká republika

+420 518 391 511 [CS]
+420 518 391 607 [RU]
+420 518 391 526 [EN]
+420 518 391 590 [DE]
export@tmachinery.cz

WWW.TMACHINERY.CZ



T MACHINERY
CZECH REPUBLIC

SHEARERS

MB 15 SERIES

Seam thickness: 1.6 - 5.5 m
Performance: 20 - 55 t/min
Total output: 1214 - 1584 kW
Operating voltage: 3300 V

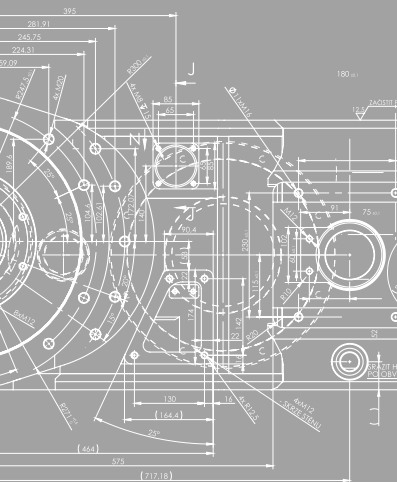

Technical parameters	MB 850E	MB 1200ESG
Length	14 590	15 250 mm
Drum diameter	1 400 - 2 250	1 800 - 2 750 mm
Seam thickness	1.6 - 4.5	2.0 - 5.5 m
Performance*	40	50 t/min.
The height of shearer from the floor**	1 400	2 000 mm
Drum RPM	29 - 47	24 - 37 r/min.
Drum width	800 - 1 000	800 - 1 000 mm
Face gradient-lingitudinal	± 35	± 35 °
Face gradient-laterall	± 20	± 25 °
Drum cutting under the conveyor	150 - 350	150 - 350 mm
Haulage speed	0 - 20	0 - 24 m/min.
Haulage pull	2 x 400	2 x 400/450 kN
Total output of motors	892	1 214 - 1 584 kW
Cutting motor power	2 x 350	2 x 500 kW
Haulage motor power	2 x 85	2 x 120 kW
Hydraulic motor power	22	2 x 22 kW
Lumpbreaker motor power	-	110 kW
Operating voltage	1 140(3 300)/660	V
Weight	85	105 t

*the coal strength max. 360 kN/m **depending on the conveyor

Batovka 1285
696 02 Ratíškovice
Česká republika

+420 518 391 511 [CS]
+420 518 391 607 [RU]
+420 518 391 526 [EN]
+420 518 391 590 [DE]
export@tmachinery.cz

WWW.TMACHINERY.CZ



T MACHINERY
CZECH REPUBLIC

SHEARER MB 900 CM

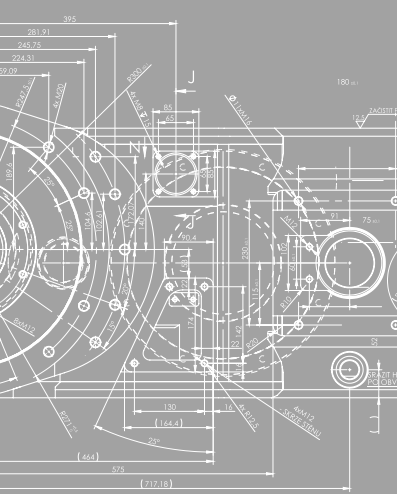
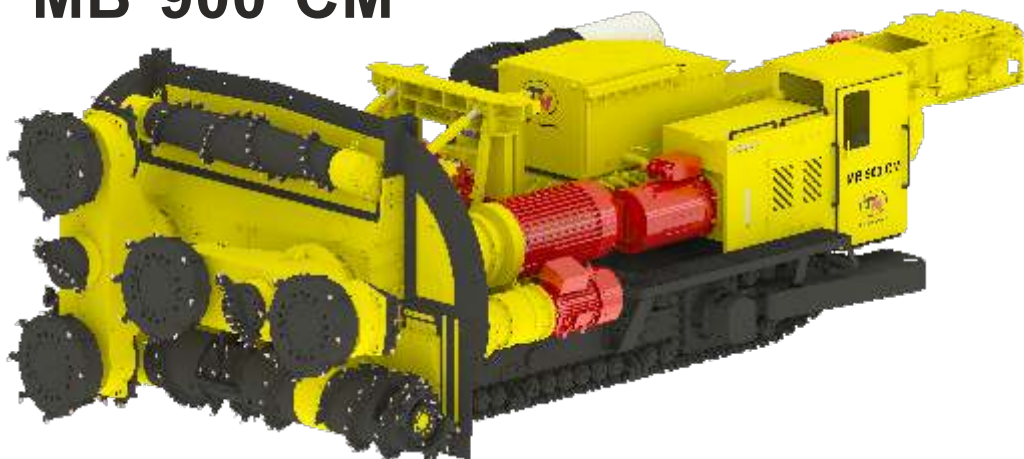

Technické parametry	MB 900 CM
Performance*	8 t/min.
Proportions of the shearer	
Profile space	15.6 m ²
Profil height	3.1 m
Profil width	5.1 m
Face gradient-longitudinal	12 °
Length	12.5 m
Weight	110 t
Cutting drums	
Main Ø 1 100 - 4x	40 r/min
Center Ø 800 - 2x	62.4 r/min
Loading Ø 820	34.6 r/min
Roof Ø 600 (conical)	46.5 r/min
Conveyor	
	scraper
Speed	1.4 m/s
Trough width	0.6 m
Pitch	0.5 m
Angle of horizontal deflection of conveyor	± 40 °
Driving system	
	caterpillar
Spacing between caterpillars	2.84 m
Caterpillar width	0.44 m
Moving speed	9 m/min
Mining speed	0.5 m/min
Total output	975 kW
Operating voltage	1 140 V
Bolting instrument	
	semi-automatic
Drilling borer diameter	42 mm
Drill bit length	1.5 m
Operating temperature	5 - 45 °C
Explosion-proof	Im2bck

*the coal strength max. 450 kN/m

Batovka 1285
696 02 Ratíškovice
Česká republika

+420 518 391 511 [CS]
+420 518 391 607 [RU]
+420 518 391 526 [EN]
+420 518 391 590 [DE]
export@tmachinery.cz

WWW.TMACHINERY.CZ



T MACHINERY
CZECH REPUBLIC

SHEARER MB 16 SERIES

Seam thickness: 1.6 - 4.6 m
Performance: 5 - 32 t/min
Total output: 330 kW
Operating voltage: 1000 V

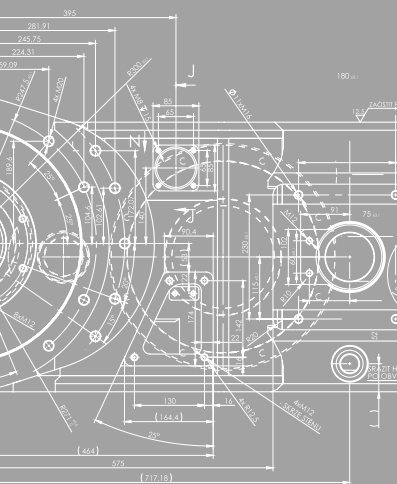
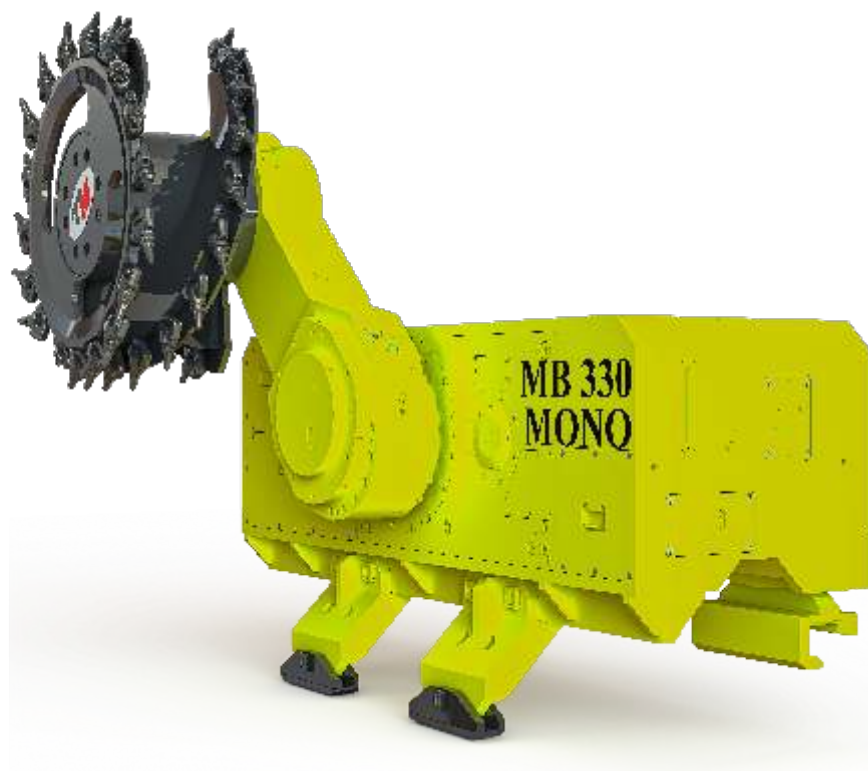

Technical parameters	MB 330 MONO
Drum diameter	1.4 - 1.8mm
Seam thickness	1.4 - 3.6 m
Performance*	5 - 32 t/min
The height of shearer from the floor**	1 500 mm
Drum RPM	48 r/min
Drum width	625 - 800 mm
Face gradient-lingitudinal	± 35 °
Face gradient-laterall	± 20 °
Drum cutting under the conveyor	400 mm
Haulage speed	0 - 6.2 m/min
Haulage pull	300 kN
Total output of motors	330 kW
Cutting motor power	1 x 300 kW
Haulage motor power	1 x 30 kW
Operating voltage	1 000 V
Weight	18.6 t

*the coal strength max. 360 kN/m **depending on the conveyor

Batovka 1285
696 02 Ratíškovice
Česká republika

+420 518 391 511 [CS]
+420 518 391 607 [RU]
+420 518 391 526 [EN]
+420 518 391 590 [DE]
export@tmachinery.cz

WWW.TMACHINERY.CZ



T MACHINERY
CZECH REPUBLIC

The MB 330 MONO shearer with a 330 kW main engine power is designed to mine short residual pillars of 1.6 to 3.5 meter thickness.

Turning the arm using a hydraulic motor with a brake and coupling against overload ensures seamless operation of the shearer.

Travel of the shearer is ensured by a separate 30 kW motor. The shearer is equipped with an online and off-line diagnostic system that allows continuous recording of the operating and fault conditions of the shearer.

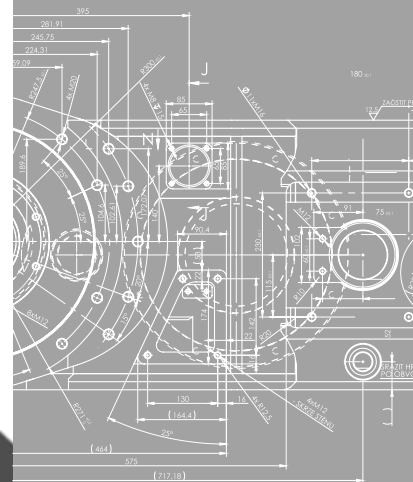
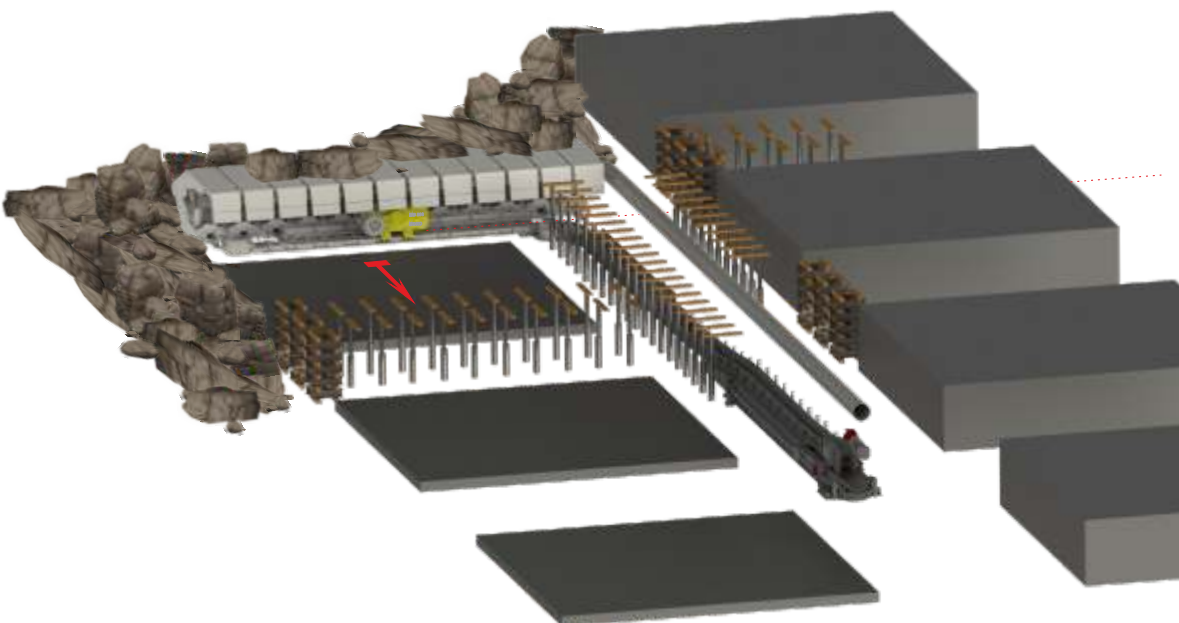
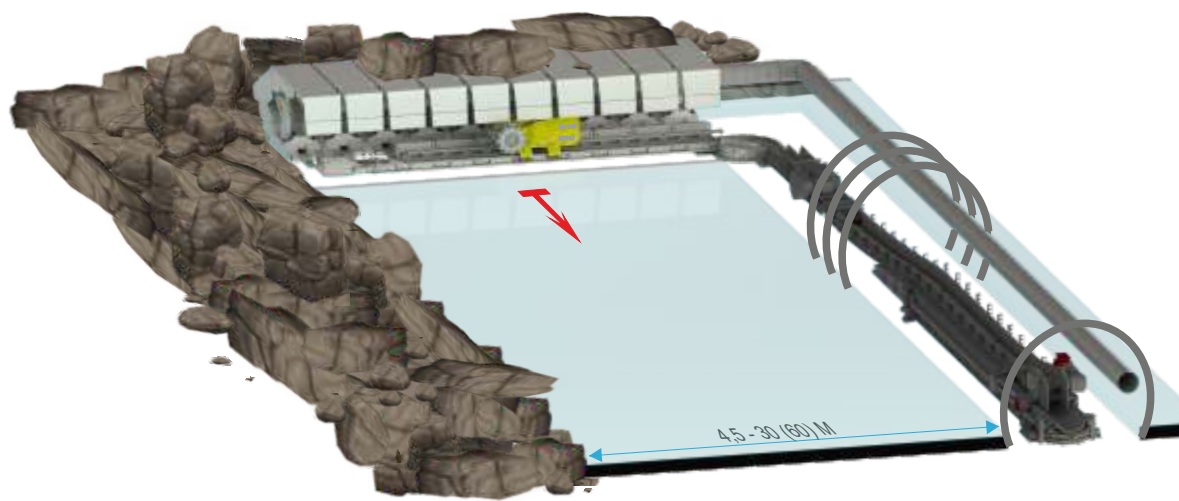

Batovka 1285
696 02 Ratíškovice
Česká republika

+420 518 391 511 [CS]
+420 518 391 607 [RU]
+420 518 391 526 [EN]
+420 518 391 590 [DE]
export@tmachinery.cz

WWW.TMACHINERY.CZ



T MACHINERY
CZECH REPUBLIC

SHEARER MB 260 LM SERIES

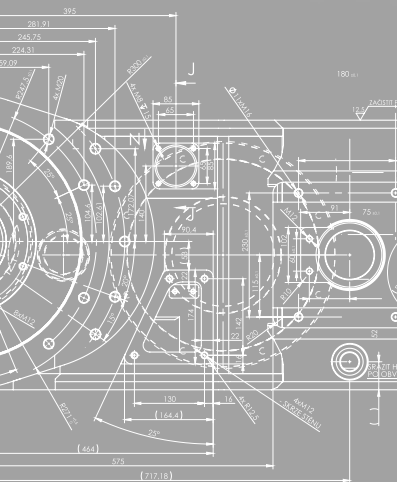
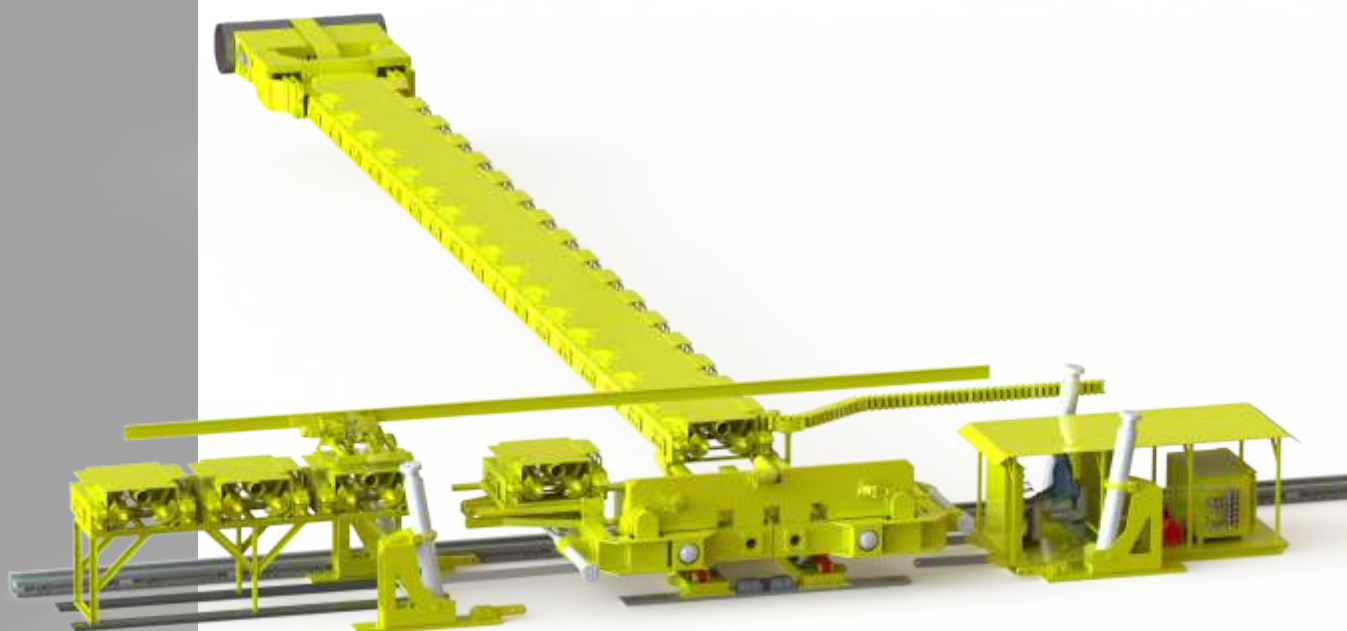

Technical parameters	MB 260 LM
Performance*	2 t/min
Profile space	4.16 m ²
Profil height	1.6 m
Profil width	2.6 m
Face gradient-longitudinal	15 °
Length	5 m
Widht	2.8 m
Height	1.8 m
Weight of the cutting part	14 t
Weight of the shearer	39 t
Weight of extension section	1.5 t
Drum RPM	60 r/min
Drum diameter	800 mm
Drum width	1 100 mm
Tilting the miner ± 15°	hydraulic
Feed the drums and extension sections into the cut	hydraulic
Working feed rate of drums	0.5 m/min
Total output	600 kW
Cutting motor power	2 x 120 kW
Worm drive motor power	2 x 120 kW
Hydraulic motor power	120 kW
Operation voltage	1 104 V

*the coal strength max. 450 kN/m

Batovka 1285
696 02 Ratíškovice
Česká republika

+420 518 391 511 [CS]
+420 518 391 607 [RU]
+420 518 391 526 [EN]
+420 518 391 590 [DE]
export@tmachinery.cz

WWW.TMACHINERY.CZ



T MACHINERY
CZECH REPUBLIC

The device is designed for extraction of residual seams, extraction of coal pillars and solidagos in small thickness seams, and at the places where it is not possible to strip the entire surface of the seam overburden, and it is necessary to retain the supporting pillars. This device can be used for the extraction of certain iron and polymetallic ores of sedimentary origin. The technology can be expanded by passage system with swum foundation and regressive mining of retained pillars. When adjusting the drive unit, it is possible to use the device for the extraction of low seams in open pit mines, where it is not possible to continue with open breakup due to excessive overburden height.

The device works on a low passage heading without support. The passage is perpendicular to the wall of the opening passage at regular intervals or according to geotechnical conditions. The front of the machine is fitted with a double cylindrical picking organ with cutting knives. The conveyor, consisting of a double screws, consists of attachable parts that are inserted at the drive station of the device in the passage using a suspension groove and a lifting device.

The device works on the basis of heading the passage with the removal of disintegrated coal into the scraper conveyor located under the mouth of the passage. After heading the 60-100 meter length of the passage, the device moves. The device and the operator's cabinet are equipped with rails for movement. The moving is done by traction of the device over the passage bottom. The device is equipped with anchoring device for sufficient stability – passage spacers.

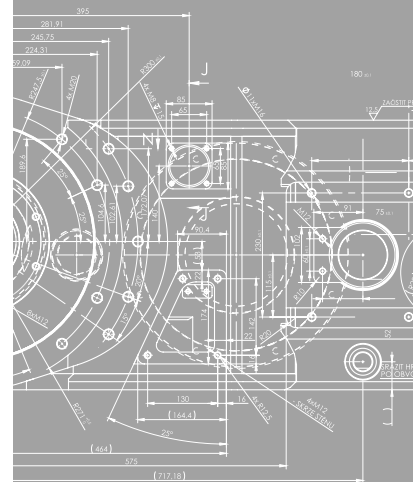
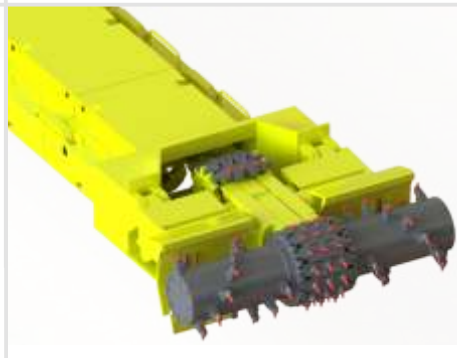
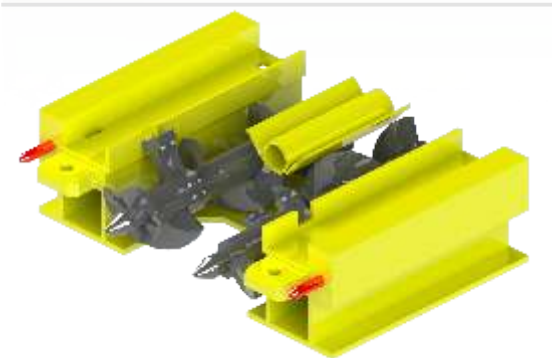
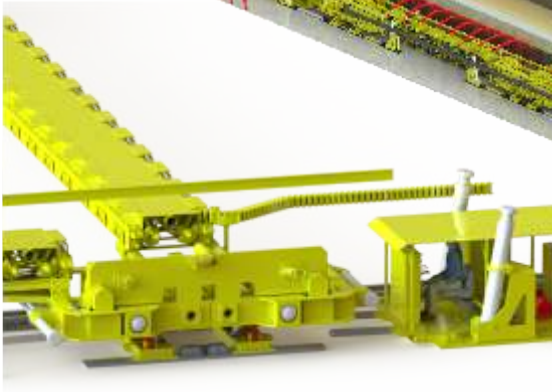
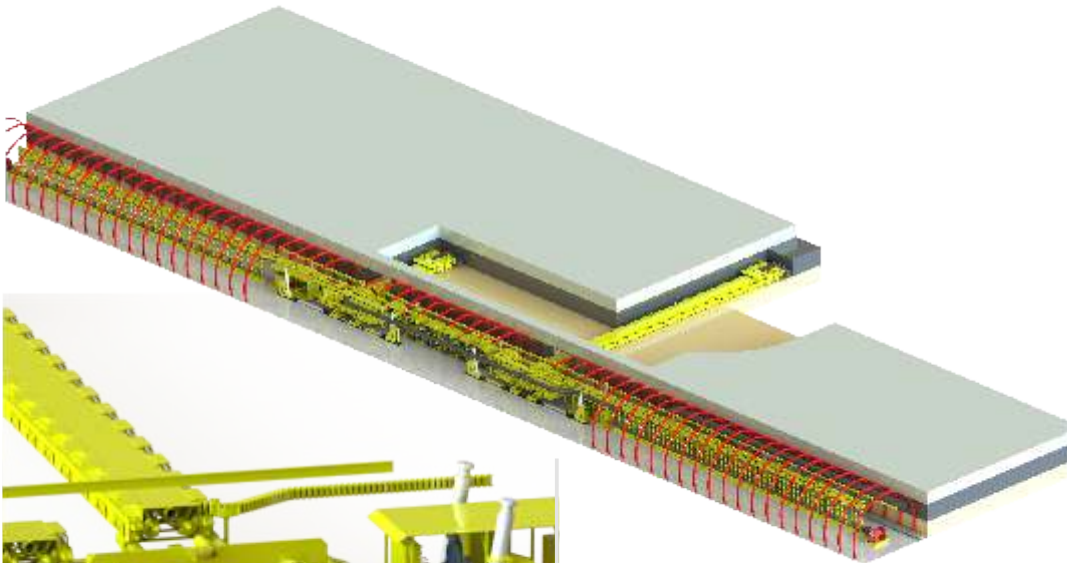

Batovka 1285
696 02 Ratíškovice
Česká republika

+420 518 391 511 [CS]
+420 518 391 607 [RU]
+420 518 391 526 [EN]
+420 518 391 590 [DE]
export@tmachinery.cz

WWW.TMACHINERY.CZ



T MACHINERY
CZECH REPUBLIC

TM VISION VIZUALIZATION SYSTEM OF MINING DEVICE OPERATION

TM Vision system is designed for surface screening of mining devices operation, manufactured by the company T Machinery a.s. Data from devices are on-line transferred into program through reserved communication line and by the help of special communication modules. This way transferred and screened data provide information both of all operational statuses that are scanned from device and of breakdown states that can occur on device. Except for screening of transferred data from device in real time, this system files all transferred data. These filed data can be effectively screened and analysed by the help of graphs by special module.

The system particularly serves for dispatcher's purposes. Using and operation of this system together with device has a positive contribution to potential service of the device. By the help of this program, servisman may localize potential breakdown more closely already in the surface, what can significantly shorten total time needed for removal of potential breakdown. The system may transfer data from mining machines of MB series, frequency converters of MFK400 type or contactors of APK9U type. By means of APK9U contactors may be monitored device that is feeded from these contactors such as rake conveyor or coalface rake conveyor.

Communication line, through which are the data sent from mining machine to the surface, consists of two basic paths. The first path is a transfer of data between mining machine in coalface and frequency changer in the corridor under coalface. The second communication path is a transfer from frequency changer to the surface. Data sent from underground to surface are stored in archiving files in PC SERVER and at the same time on-line provided into LAN network. Personal computers containing CLIENT software are connected to LAN network.

The system enables to transfer all physical quantities, measured in mining machine by means of sensors, to the surface. These quantities are e.g. driving speed, mining machine position, mining machine or its arms inclination, temperature and level of all oil fillings, temperatures of all engines (winding and bearings), mining machine voltage and currents of all engines power, flowrate and cooling water pressure, occurrence of methane, etc. The system also transfers all breakdown reports from the mining machine, entered operator's orders, etc. Data transferred from frequency convertor or contactors, contain mainly information about voltages, powers and frequencies. Next, also data about state of individual cabel outputs protections, connected force elements, orders or breakdown states of control unit.

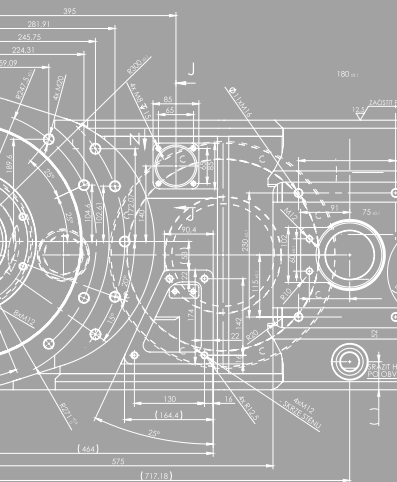

Batovka 1285
696 02 Ratíškovice
Česká republika

+420 518 391 511 [CS]
+420 518 391 607 [RU]
+420 518 391 526 [EN]
+420 518 391 590 [DE]
export@tmachinery.cz

WWW.TMACHINERY.CZ

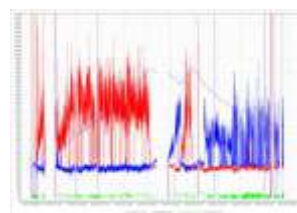



T MACHINERY
CZECH REPUBLIC

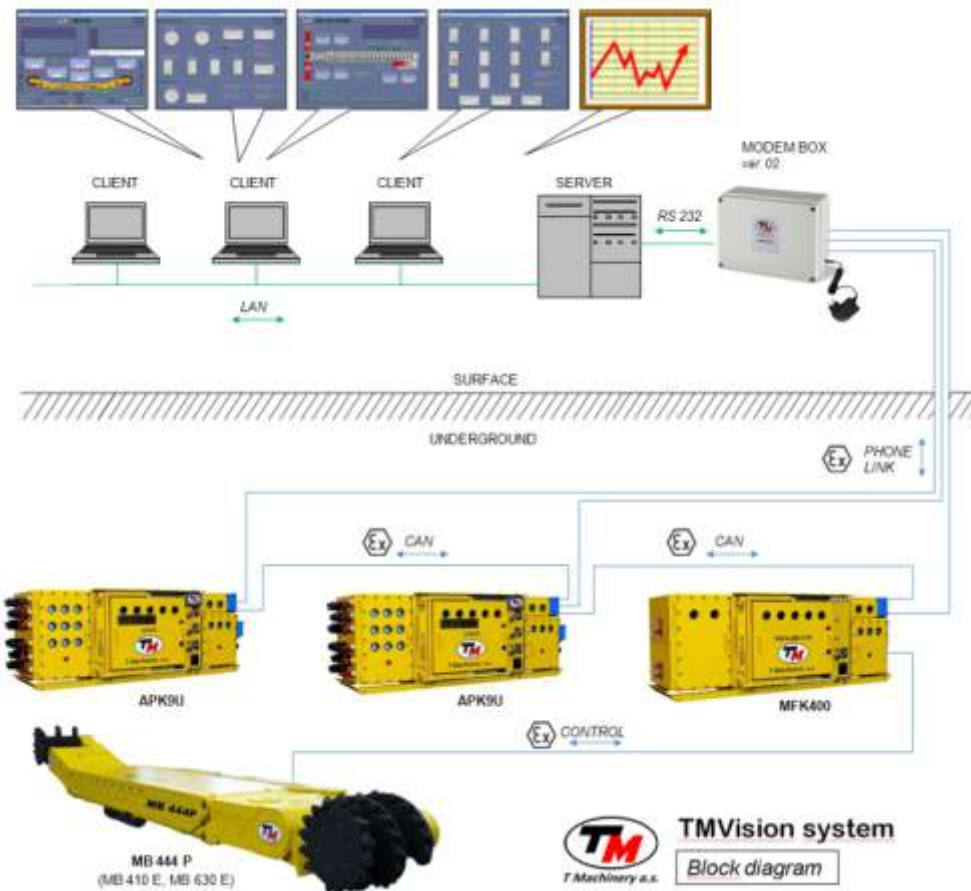

This variation shows system connection in case that data from more devices working in the given complex must be transferred. In this arrangement three telephone lines (3x2 twisted cables) are required for transfer of data. This connection is characterized by a higher operational liability of data transfer to the surface. In case of failure of one or two telephone lines the data can be temporarily transferred to the remaining operating line thanks to spark safe communication line CAN.

SW systém TM Vision

Name of item	Note	Location	Order no.
VIZUALIZATION CASE	SW is solved individually according to the needs of each client	SERVER + CLIENT	01-692-02/00

Hardware minimum requirements

Hardware	Given hardware minimum requirements
PC CLIENT	Processor 2 GHz, RAM 2 GB, HDD 300 GB, OS Windows XP or newer, network card, monitor with minimum resolution of 1280 x 1024!
PC SERVER	Interface RS232, OS Windows XP or newer, 1 or 3 serial ports D-SUB9 (according to configuration, e.g. via PCI card)
MODEM-BOX	Network voltage 230V/AC 50Hz.
PC CLIENT and PC SERVER	Processor 2 GHz, RAM 2 GB, HDD 300 GB, interface RS232, OS Windows XP or newer, 1 or 3 serial ports D-SUB9 (according to configuration, e.g. via PC cards), network card, monitor with minimum resolution of 1280 x 1024

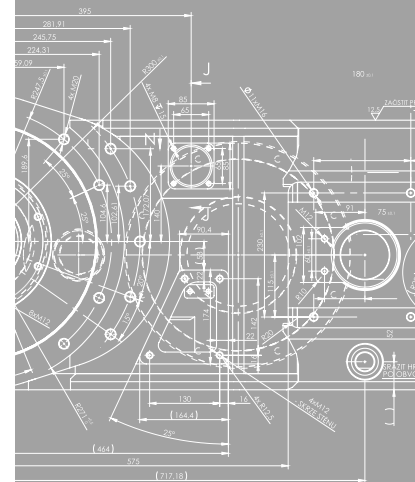

Batovka 1285
696 02 Ratíškovice
Česká republika

+420 518 391 511 [CS]
+420 518 391 607 [RU]
+420 518 391 526 [EN]
+420 518 391 590 [DE]
export@tmachinery.cz

WWW.TMACHINERY.CZ



T MACHINERY
CZECH REPUBLIC

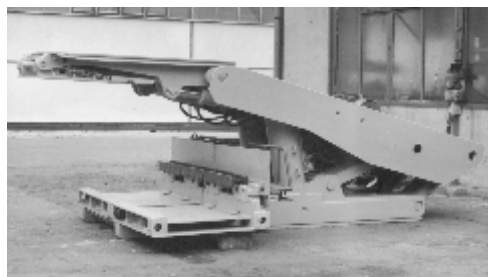

Powered roof supports ensure the mined area, safety of workers at the face and efficient and safe cave control. Mechanically powered supports produced by T Machinery a.s. are designed to withstand high pressures from the overburden and, at the same time, to safely perform the movement of wall conveyor at high stability.

Hydraulic stands and cylinders are produced directly in Ratíškovice. Production supervision allows the customer to provide a warranty for the operation of sections up to 50 000 service cycles.



POWERED ROOF SUPPORTS

Fitting the stands in the sections of mechanically powered supports by impact valves extend their use to deposits with the danger of mountain shakes.

T Machinery a.s. produces the supports in the ranges for low to medium thickness, but also for the extraction of steep seams or for the extraction of thick seams by the method of discharging the seam bridge from over the ceiling. T Machinery a.s., as one of the few companies, produces shield supports to provide space for lignite mining.

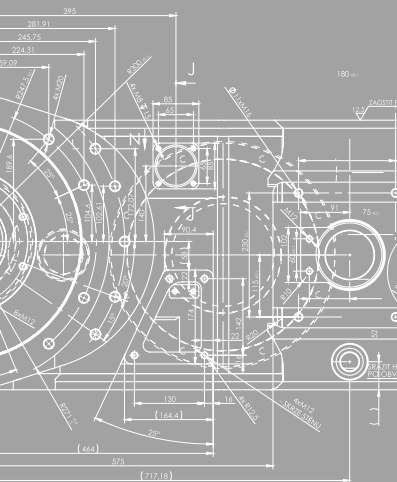

Batovka 1285
696 02 Ratíškovice
Česká republika

+420 518 391 511 [CS]
+420 518 391 607 [RU]
+420 518 391 526 [EN]
+420 518 391 590 [DE]
export@tmachinery.cz

WWW.TMACHINERY.CZ



T MACHINERY
CZECH REPUBLIC

POWERED ROOF SUPPORTS MVPO 800



Technical parameters

Configuration	0.7/1.8
Min. height	700 mm
Max. height	1 800 mm
Working range	800 - 1 750 mm
Face gradient-longitudinal	$\pm 35^\circ$
Face gradient-laterall	$\pm 25^\circ$
Pitch	1 200 mm
Width	1 160 mm
Max. resistance	340 kN/m ²
Min. resistance	300 kN/m ²
Step	650 - 800 mm
Max. capability	800 kN
Min. capability	800 kN
Support advance force	105 kN
Conveyor advance force	105 kN
Active pre-roof bar	ano
Working pressure	32 Mpa
Safety pressure	38 Mpa
Number of props per support	2 pcs
Capability of prop	400 kN
Diameter of prop	160 mm
Pressure on th floor	0.5 Mpa
Number of functions	8
Weight	2.5 t

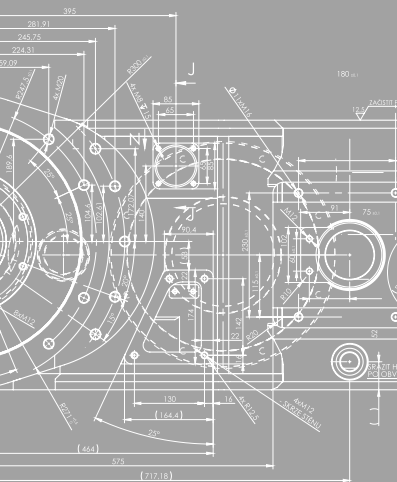

Batovka 1285
696 02 Ratíškovice
Česká republika

+420 518 391 511 [CS]
+420 518 391 607 [RU]
+420 518 391 526 [EN]
+420 518 391 590 [DE]
export@tmachinery.cz

WWW.TMACHINERY.CZ



T MACHINERY
CZECH REPUBLIC

POWERED ROOF SUPPORTS MVPO 2 800



Technical parameters

Configuration	0.7/2.1	0.8/1.9	0.9/2.4
Min. height	700	800	900 mm
Max. height	2 100	1 900	2 400 mm
Working range	800 - 2 000	900 - 1 800	1 000 - 2 300 mm
Face gradient-lingitudinal	± 35	± 25	± 35 °
Face gradient-laterall	± 25	± 25	± 25 °
Pitch	1 500	1 500	1 500 mm
Width	1 460	1 460	1 460 mm
Max. resistance	585	620	590 kN/m ²
Min. resistance	485	460	500 kN/m ²
Step	650 - 800	650 - 800	650 - 800 mm
Max. capability	3 200	3 680	3 200 kN
Min. capability	2 800	2 800	2 800 kN
Support advance force	392	392	392 kN
Conveyor advance force	231	189	231 kN
Active pre-roof bar	ano	ano	ano
Working pressure	32	32	32 Mpa
Safety pressure	40	45	40 Mpa
Number of props per support	2	2	2 pcs
Capability of prop	1 400	2 000	1 400 kN
Diameter of prop	220	240	220 mm
Pressure on th floor	1.4	2	1.4 Mpa
Number of functions	8 - 14	8 - 14	8 - 14
Weight	7.85	9.1	8.1 t

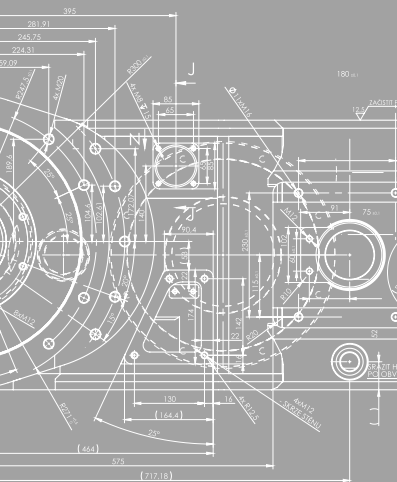

Batovka 1285
696 02 Ratíškovice
Česká republika

+420 518 391 511 [CS]
+420 518 391 607 [RU]
+420 518 391 526 [EN]
+420 518 391 590 [DE]
export@tmachinery.cz

WWW.TMACHINERY.CZ



T MACHINERY
CZECH REPUBLIC

POWERED ROOF SUPPORTS MVPO 3 200



Technical parameters

Configuration	2.0/3.2
Min. height	2 000 mm
Max. height	3 200 mm
Working range	2 600 - 3 100 mm
Face gradient-longitudinal	$\pm 10^\circ$
Face gradient-laterall	$\pm 20^\circ$
Pitch	1 500 mm
Width	1 460 mm
Max. resistance	650 kN/m ²
Min. resistance	590 kN/m ²
Step	650 - 800 mm
Max. capability	3 200 kN
Min. capability	2 400 kN
Support advance force	440 kN
Conveyor advance force	303 kN
Active pre-roof bar	ano
Working pressure	32 Mpa
Safety pressure	40 Mpa
Number of props per support	2 pcs
Capability of prop	1 600 kN
Diameter of prop	220 mm
Pressure on th floor	1 Mpa
Number of functions	16
Weight	12 t

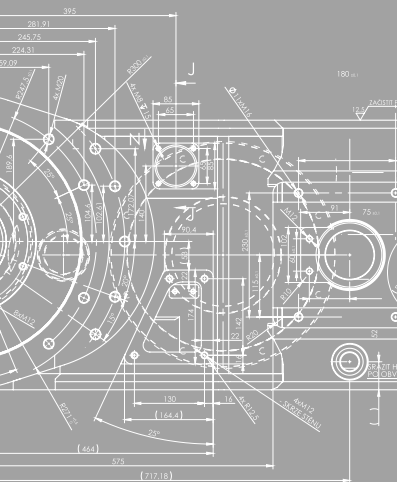

Batovka 1285
696 02 Ratíškovice
Česká republika

+420 518 391 511 [CS]
+420 518 391 607 [RU]
+420 518 391 526 [EN]
+420 518 391 590 [DE]
export@tmachinery.cz

WWW.TMACHINERY.CZ



T MACHINERY
CZECH REPUBLIC

POWERED ROOF SUPPORTS MVPO 3 200 X



Technical parameters

Configuration	0.55/1.6	0.75/1.8
Min. height	550	750 mm
Max. height	1 600	1 800 mm
Working range	650 - 1 500	850 - 1 700 mm
Face gradient-longitudinal	± 35	± 35 °
Face gradient-laterall	± 25/±15	± 25/±15 °
Pitch	1 500	1 500 mm
Width	1 460	1 460 mm
Max. resistance	620	630 kN/m ²
Min. resistance	520	530 kN/m ²
Step	650 - 800	650 - 800 mm
Max. capability	3 200	3 200 kN
Min. capability	2 350	2 350 kN
Support advance force	303	303 kN
Conveyor advance force	180	180 kN
Active pre-roof bar	ano	ano
Working pressure	32	32 Mpa
Safety pressure	42	42 Mpa
Number of props per support	4	4 pcs
Capability of prop	800	800 kN
Diameter of prop	160	160 mm
Pressure on th floor	1.4	1.4 Mpa
Number of functions	10	10
Weight	7.8	8.05 t

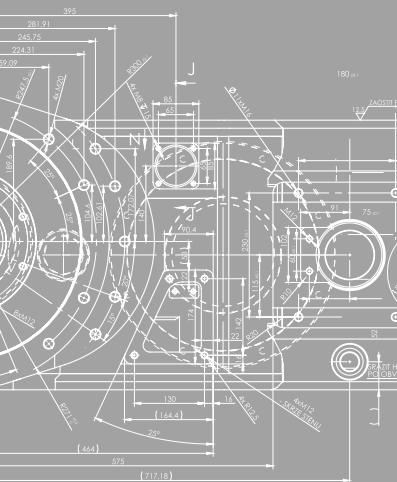

Batovka 1285
696 02 Ratíškovice
Česká republika

+420 518 391 511 [CS]
+420 518 391 607 [RU]
+420 518 391 526 [EN]
+420 518 391 590 [DE]
export@tmachinery.cz

WWW.TMACHINERY.CZ



T MACHINERY
CZECH REPUBLIC

POWERED ROOF SUPPORTS MVPO 4 200



Technical parameters

Configuration	0.8/1.5
Min. height	800 mm
Max. height	1 500 mm
Working range	900 - 1 400 mm
Face gradient-longitudinal	$\pm 40^\circ$
Face gradient-laterall	$\pm 30^\circ$
Pitch	1 500 mm
Width	1 460 mm
Max. resistance	647 kN/m ²
Min. resistance	544 kN/m ²
Step	800 mm
Max. capability	4 275 kN
Min. capability	3 356 kN
Support advance force	180 kN
Conveyor advance force	304 kN
Active pre-roof bar	ano
Working pressure	32 Mpa
Safety pressure	42 Mpa
Number of props per support	4 pcs
Capability of prop	1 068 kN
Diameter of prop	180 mm
Pressure on th floor	1.4 Mpa
Number of functions	10
Weight	8 t

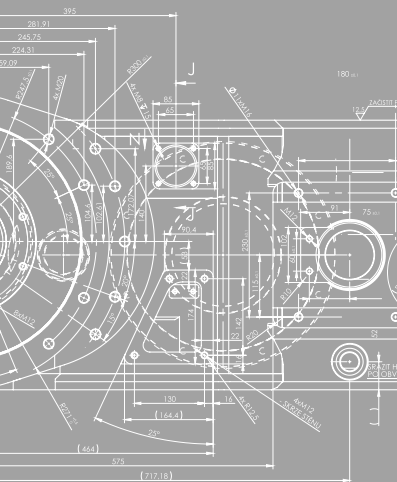

Batovka 1285
696 02 Ratíškovice
Česká republika

+420 518 391 511 [CS]
+420 518 391 607 [RU]
+420 518 391 526 [EN]
+420 518 391 590 [DE]
export@tmachinery.cz

WWW.TMACHINERY.CZ



T MACHINERY
CZECH REPUBLIC

POWERED ROOF SUPPORTS MVPO 5 600



Technical parameters

Configuration	0.9/1.9
Min. height	800 mm
Max. height	1 900 mm
Working range	900 - 1 800 mm
Face gradient-longitudinal	$\pm 25^\circ$
Face gradient-laterall	$\pm 25^\circ$
Pitch	1 500 mm
Width	1 480 mm
Max. resistance	795 kN/m ²
Min. resistance	551 kN/m ²
Step	700 - 800 mm
Max. capability	7 180 kN
Min. capability	4 970 kN
Support advance force	392 kN
Conveyor advance force	189 kN
Active pre-roof bar	ano
Working pressure	32 Mpa
Safety pressure	42 Mpa
Number of props per support	4 pcs
Capability of prop	1 900 kN
Diameter of prop	180 mm
Pressure on th floor	2.8 Mpa
Number of functions	8
Weight	13.77 t

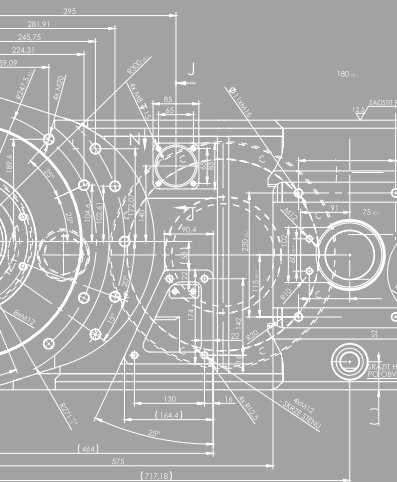

Batovka 1285
696 02 Ratíškovice
Česká republika

+420 518 391 511 [CS]
+420 518 391 607 [RU]
+420 518 391 526 [EN]
+420 518 391 590 [DE]
export@tmachinery.cz

WWW.TMACHINERY.CZ



T MACHINERY
CZECH REPUBLIC



Scraper conveyors manufactured by T Machinery a.s. company are an integral part of mining complexes. A substantial part of the production consists of scraper conveyors designed for travel of shearer and for extraction of disintegrated coal.

These conveyors excel in their durability and flexibility. Drive stations can be equipped with up to four, water-cooled, motors to achieve the highest mining power. Conveyor motors are certified with ATEX.



ARMORED FACE CONVEYORS

The conveyors are manufactured from E-profiles of standard quality, as well as according to special design of T Machinery a.s. The abrasion resistance is increased by special laser hardening, which is carried out on the inner surfaces of the E profile.

Leading of traction chains may be extreme or central. The conveyor track is composed of welded troughs. Insertion into the trough track with inspection windows allows for inspection and maintenance over the entire conveyor length without time losses. The trough connection is flexible with a permissible load of 2 500 kN.

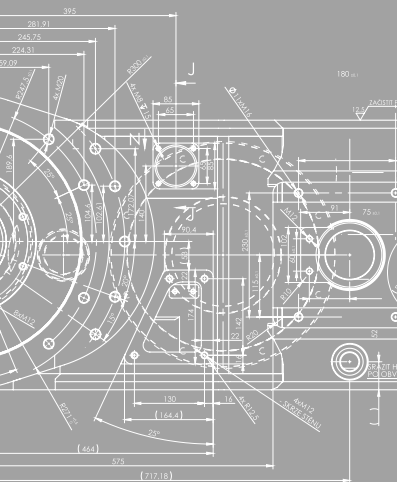

Batovka 1285
696 02 Ratíškovice
Česká republika

+420 518 391 511 [CS]
+420 518 391 607 [RU]
+420 518 391 526 [EN]
+420 518 391 590 [DE]
export@tmachinery.cz

WWW.TMACHINERY.CZ



T MACHINERY
CZECH REPUBLIC

ARMORED FACE CONVEYORS HD 190

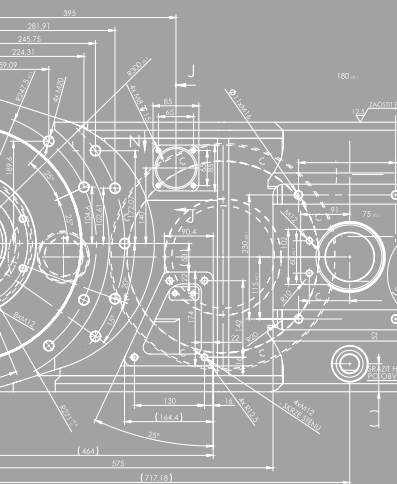
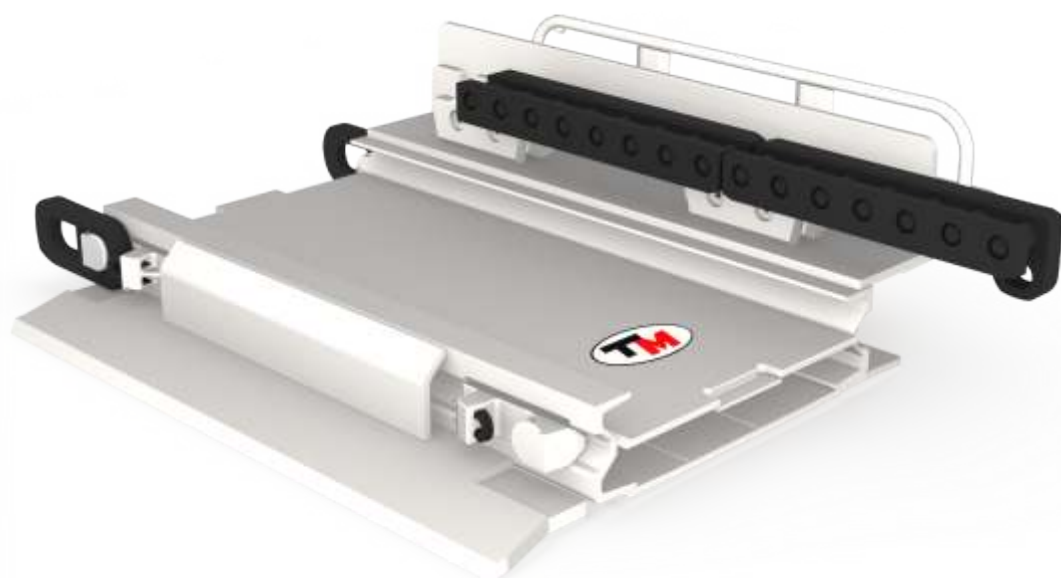

Batovka 1285
696 02 Ratíškovice
Česká republika

+420 518 391 511 [CS]
+420 518 391 607 [RU]
+420 518 391 526 [EN]
+420 518 391 590 [DE]
export@tmachinery.cz

WWW.TMACHINERY.CZ

Technical parameters	190/800	190/642
Transport capacity	700	650 t/h
Moving speed	1.1	1.1 m/s
Board middle sheet	Abrasive steel Hardox	
Board middle sheet thickness	25	25 mm
Board lower sheet thickness	15	15 mm
Board trough construction is all welded with side and shearer line		
Permissible loading on trough connection	1 600	1 600 kN
Chain	2x26x92	2x26x92 mm
Chain pitch	200/350	200 mm
Scrapers	Forged	
Gearboxes	4xPL15 nebo 4xPL25	
Electric motors	4x250/85	4x200/65 kW
Max. conveyor length	300	300 m
Service life	2 mil.	2 mil. t



T MACHINERY
CZECH REPUBLIC

ARMORED FACE CONVEYORS HD 228

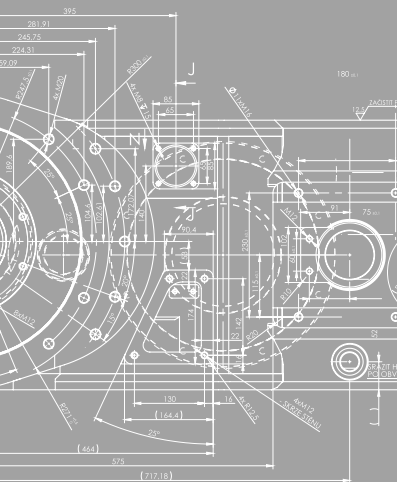

Technical parameters	228/642	228/732
Transport capacity	700	800(900) t/h
Moving speed	1.1	0.95 (1.1) m/s
Board middle sheet	Abrasive steel Hardox	
Board middle sheet thickness	25	30 mm
Board lower sheet thickness	15	20 mm
Board trough construction is all welded with side and shearer line		
Permissible loading on trough connection	1 600	2 000 kN
Chain	2x30x108	2x30x108 mm
Chain pitch	200	130 mm
Scrapers	Forged	
Gearboxes	4xPL15 nebo 4xPL25	
Electric motors	4x250/85	4x250/65 4x250/85 kW 4x315/100
Max. conveyor length	300	350 m
Service life	2 mil.	3 mil. t

Batovka 1285
696 02 Ratíškovice
Česká republika

+420 518 391 511 [CS]
+420 518 391 607 [RU]
+420 518 391 526 [EN]
+420 518 391 590 [DE]
export@tmachinery.cz

WWW.TMACHINERY.CZ



T MACHINERY
CZECH REPUBLIC

ARMORED FACE CONVEYORS HD 228

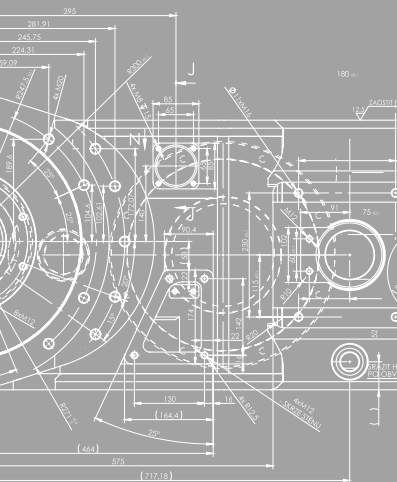
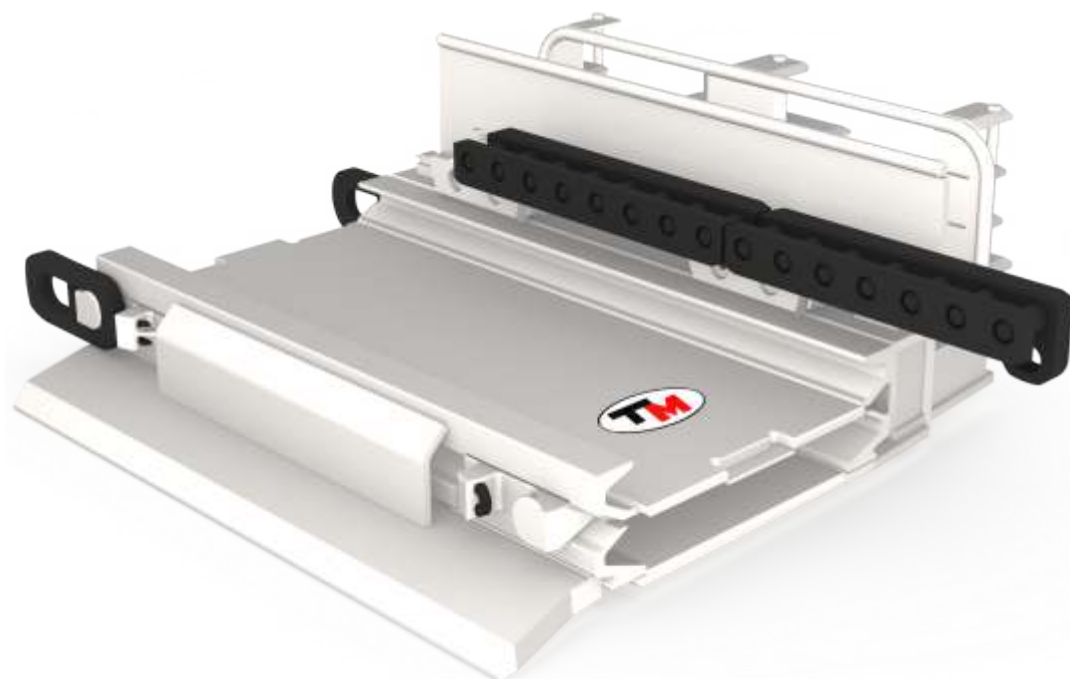

Technical parameters	228/800	228/832
Transport capacity	900 (1 000)	1 000(1 100) t/h
Moving speed	0.95 (1.1)	0.95 (1.1) m/s
Board middle sheet	Abrasive steel Hardox	
Board middle sheet thickness	30	30 mm
Board lower sheet thickness	15	20 mm
Board trough construction is all welded with side and shearer line		
Permissible loading on trough connection	2 000	2 000 kN
Chain	2x30x108	2x30x108 mm
Chain pitch	280	130 mm
Scrapers	Forged	
Gearboxes	4xPL15 nebo 4xPL25	
Electric motors	4x250/85	4x250/65 4x250/85 kW 4x315/100
Max. conveyor length	350	350 m
Service life	3 mil.	3 mil. t

Batovka 1285
696 02 Ratíškovice
Česká republika

+420 518 391 511 [CS]
+420 518 391 607 [RU]
+420 518 391 526 [EN]
+420 518 391 590 [DE]
export@tmachinery.cz

WWW.TMACHINERY.CZ



T MACHINERY
CZECH REPUBLIC

ARMORED FACE CONVEYORS HD 260

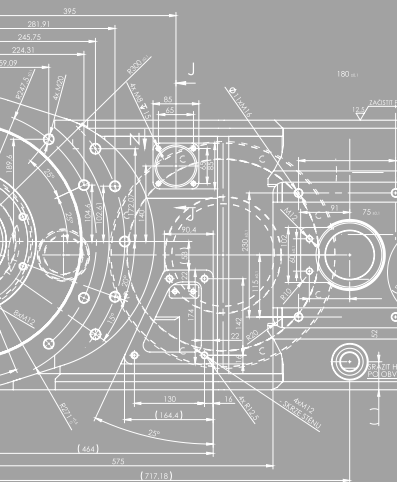
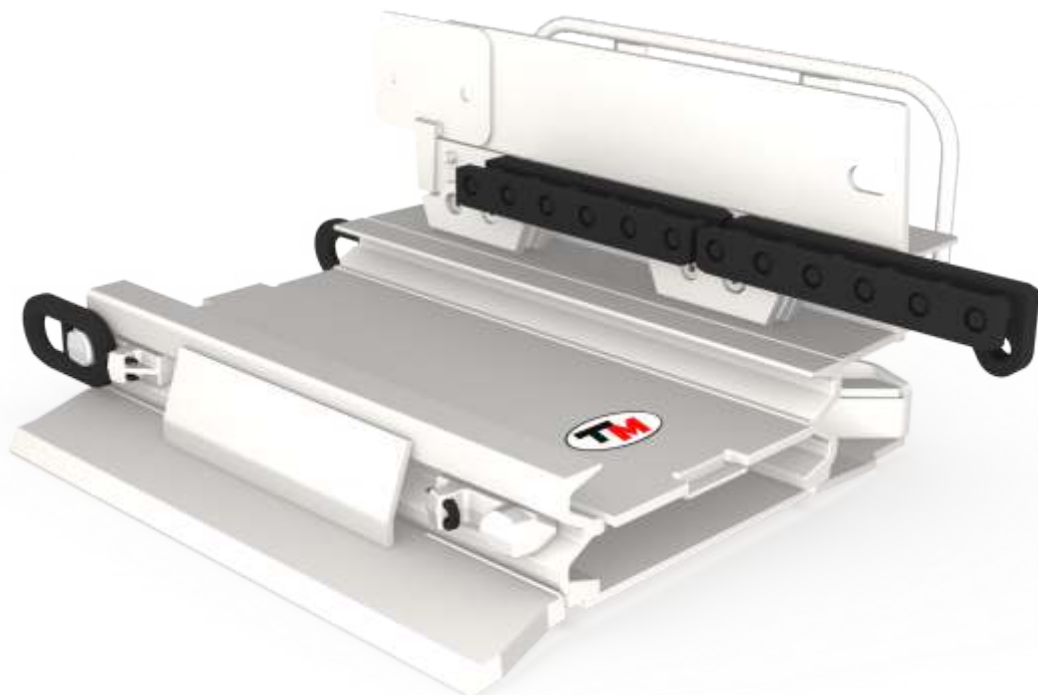

Technical parameters	260/852
Transport capacity	1 200 t/h
Moving speed	0.95 (1.1) m/s
Board middle sheet	Abrasive steel Hardox
Board middle sheet thickness	35 mm
Board lower sheet thickness	20 mm
Board trough construction is all welded with side and shearer line	
Permissible loading on trough connection	2 500 kN
Chain	2x30x108 mm
Chain pitch	280 mm
Scrapers	Forged
Gearboxes	4xPL15 nebo 4xPL25
Electric motors	4x250/85 4x315/100 kW
Max. conveyor length	350 m
Service life	3 mil. t

Batovka 1285
696 02 Ratíškovice
Česká republika

+420 518 391 511 [CS]
+420 518 391 607 [RU]
+420 518 391 526 [EN]
+420 518 391 590 [DE]
export@tmachinery.cz

WWW.TMACHINERY.CZ



T MACHINERY
CZECH REPUBLIC

ARMORED FACE CONVEYORS HD 284

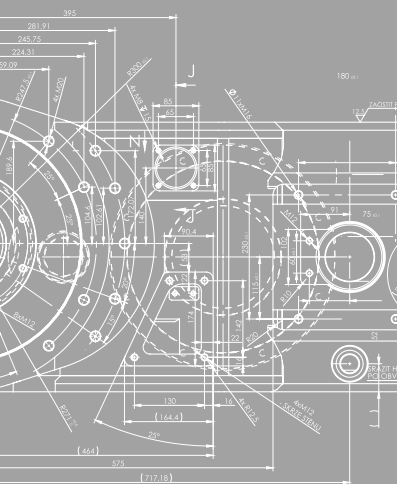
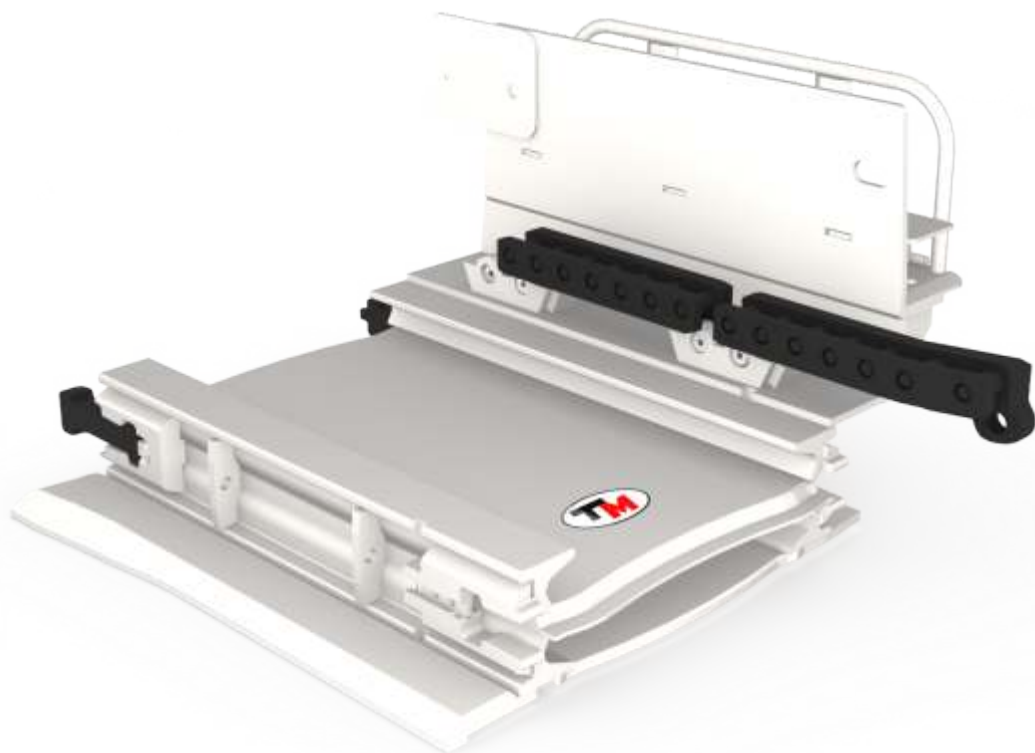

Technical parameters	284/832	284/932	284/1032
Transport capacity	1100 (1200)	1300 (1400)	1600(1800) t/h
Moving speed		0.95 (1.1)	m/s
Board middle sheet	Abrasive steel Hardox		
Board middle sheet thickness		40	mm
Board lower sheet thickness		20	mm
Board trough construction is all welded with side and shearer line			
Permissible loading on trough connection		2 500	kN
Chain		2x34x126	mm
Chain pitch		150	mm
Scrapers			Forged
Gearboxes	4xPL25 nebo 4xPL35		
Electric motors	4x250/85 // 4x315/100 // 4x400/135		
Max. conveyor length		350	m
Service life		3 mil.	t

Batovka 1285
696 02 Ratíškovice
Česká republika

+420 518 391 511 [CS]
+420 518 391 607 [RU]
+420 518 391 526 [EN]
+420 518 391 590 [DE]
export@tmachinery.cz

WWW.TMACHINERY.CZ



T MACHINERY
CZECH REPUBLIC

ARMORED CURVED CONVEYORS HD 228/732U



Armored curved rare conveyor HD 228/732 U is a conveyor for haulage of caved top coal for longwall top coal caving mining technology and for short wall technology with blind single-wing wall.

Conveyor has a long service lifetime and it is equipped with 250 kW powerful motor. Conveyor HD 228/732 U could be used as a beam stage Loader with removable connection with coal face and belt conveyor.

Conveyor is produced from high abrasion resistant materials as HARDOX or WELDOX. Pan width is 732 mm. Hight of "E" profile is 228 mm. "E" profiles are hardened with a special laser technology for higher abrasion resistance.



Technical parameters

228/732U

Transport capacity	900 t/h
Moving speed	0.95 (1.1) m/s
Board middle sheet	Abrasive steel Hardox
Board middle sheet thickness	35 mm
Board lower sheet thickness	20 mm
Board trough construction is all welded with side and shearer line	
Permissible loading on trough connection	2 500 kN
Chain	2x34x126
Chain pitch	150 mm
Scrapers	Forged
Gearboxes	PI15 nebo PL25
Electric motors	250 kW
Max. conveyor length	170 m
Service life	3 mil. t

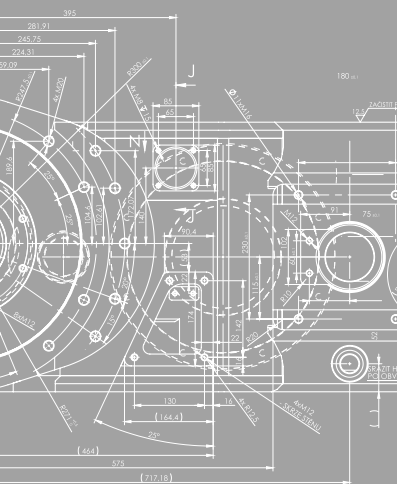

Batovka 1285
696 02 Ratíškovice
Česká republika

+420 518 391 511 [CS]
+420 518 391 607 [RU]
+420 518 391 526 [EN]
+420 518 391 590 [DE]
export@tmachinery.cz

WWW.TMACHINERY.CZ



POSSIBILITY OF CONNECTION

MB 444P/MVPO 2800/HD 228/642

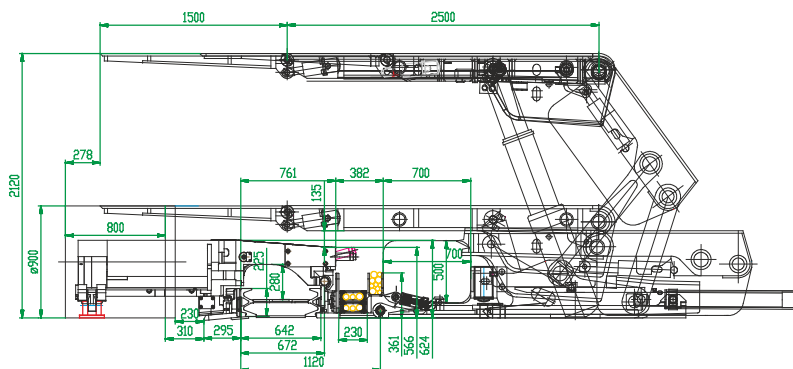

MB 444P/MVPO 3200X/HD 228/642

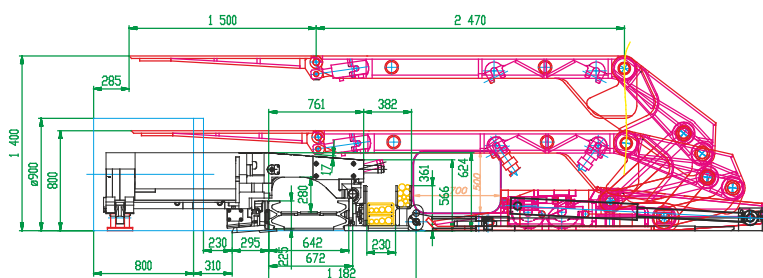

MB 410E/MVPO 3500/HD 228/642

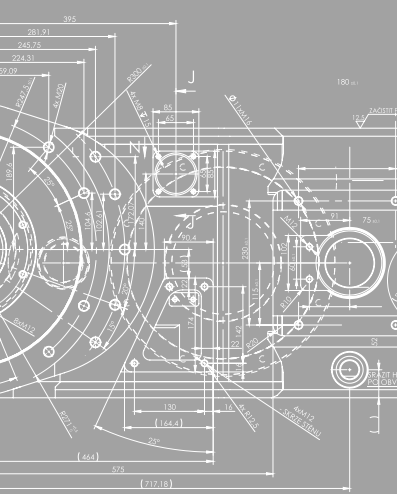
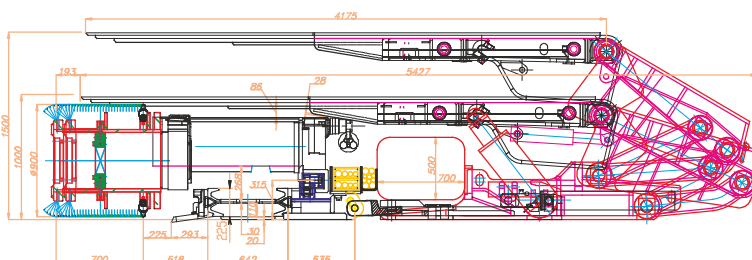

Batovka 1285
696 02 Ratíškovice
Česká republika

+420 518 391 511 [CS]
+420 518 391 607 [RU]
+420 518 391 526 [EN]
+420 518 391 590 [DE]
export@tmachinery.cz

WWW.TMACHINERY.CZ

Shearer	Power roof support	Conveyor
MB 280 E	MVPO 3200X	HD 190/642
MB 410 E	MVPO 3500	HD 228/642
MB 444 P	MVPO 4200	HD 228/732
MB 320 E	MVPO 4.01?????????	HD 228/800
MB 410 E	MVPO 2800	HD 228/732



T MACHINERY
CZECH REPUBLIC



An integral part of each mining complex is the electrical equipment necessary for powering and controlling individual devices. In this area, T Machinery a.s. offers APK9U contactor set for switching up to nine independent MFK400 frequency inverter drives for powering and regulation of the travel equipment of shearers and auxiliary voltage transformation.



SWITCHING POWER SYSTEMS

All of these devices have outputs that allow the transfer of traffic information to both the other devices in the complex and to the dispatching station on the mine surface.

All the electrical devices supplied by us are manufactured in accordance with the requirements of Directive 2014/34/EU (ATEX) and in accordance with the equivalent directives of the Russian Federation and Ukraine.

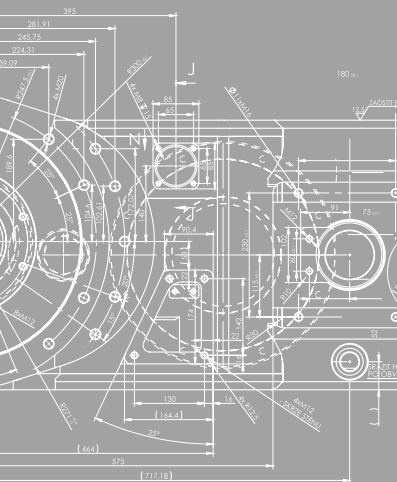

Batovka 1285
696 02 Ratíškovice
Česká republika

+420 518 391 511 [CS]
+420 518 391 607 [RU]
+420 518 391 526 [EN]
+420 518 391 590 [DE]
export@tmachinery.cz

WWW.TMACHINERY.CZ



T MACHINERY
CZECH REPUBLIC

CONTACTOR APK9U

This high-voltage cabinet is made for explosive implementation and is intended for operation in deep coalmines (Classification Im2). The cabinet body provides protection level IP 54. The high-voltage cabinet is a welded, multi compartment steel structure with a quickly lockable shutter. This equipment is intended for switching on/off electric motor with tension 1440V/ 660V - to a maximum of 9 motors. Strength contactors are divided to three separate circuits.

The contactor designed for switching two to four drive scraper conveyors includes an assistance algorithm that can be used to switch the conveyor in the following modes:

Servis mode:

- low speed of the upper drive in the direction
- low speed of the upper drive against the direction
- low speed of downstream drive
- low speed of the lower drive against the direction
-

Working mode:

- low speed direction
- low speed against the direction
- working speed

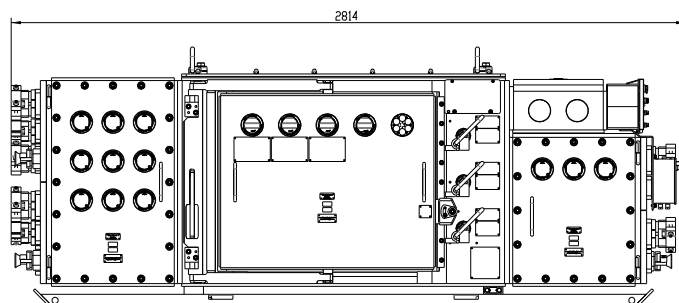
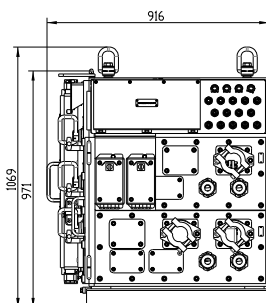
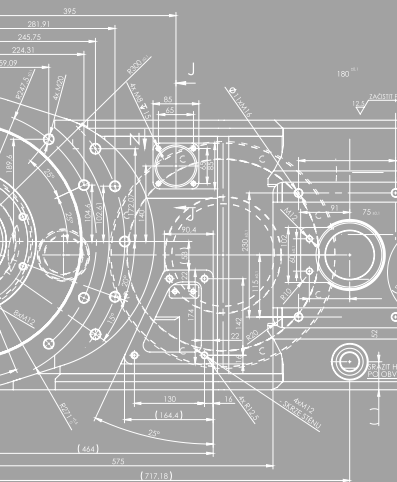

Batovka 1285
696 02 Ratíškovice
Česká republika

+420 518 391 511 [CS]
+420 518 391 607 [RU]
+420 518 391 526 [EN]
+420 518 391 590 [DE]
export@tmachinery.cz

WWW.TMACHINERY.CZ



T MACHINERY
CZECH REPUBLIC

CONTACTOR APK9U

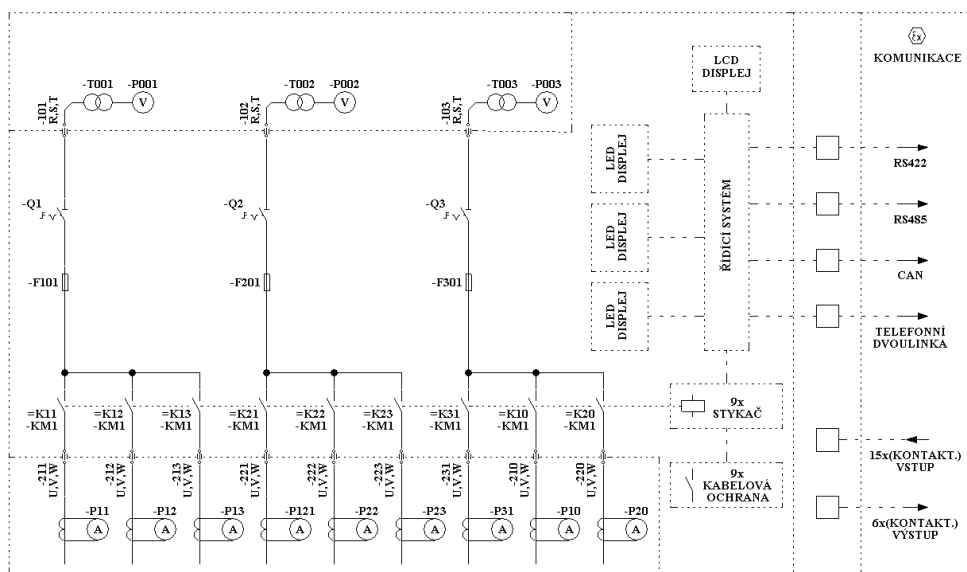

Shifting power contactors into branches

Option	1.branch	2.branch	3.branch
333	K11, K12, K13	K21, K22, K23	K31, K10, K20
342	K11, K12, K13	K20, K21, K22, K23	K31, K10
441	K10, K11, K12, K13	K20, K21, K22, K23	K31

Technical parameters

Operating voltage	1 140/660, 1000/500 V/AC
Frequency	50, 60 Hz
Maximum current	1 200 A
Dielectric strength	25 kA
Number of contactors	9 ks
Dimension (length, height, width)	2741 x 943 x 916 mm
Weight	2 520 kg
Operation temperature	0 - 40 °C
Rate of protection	IP 54

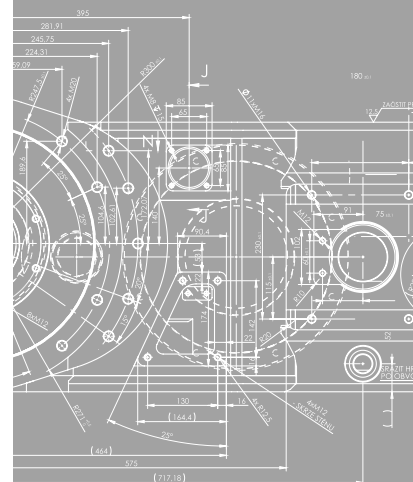

Batovka 1285
696 02 Ratíškovice
Česká republika

+420 518 391 511 [CS]
+420 518 391 607 [RU]
+420 518 391 526 [EN]
+420 518 391 590 [DE]
export@tmachinery.cz

WWW.TMACHINERY.CZ



T MACHINERY
CZECH REPUBLIC

FREQUENCY CONVERTOR MFK 400.KDx

Frequency converter MFK400.KDx is made in explosion-proof design and is intended for power supply of electric motors of mining harvesters in underground coal mines with the danger of methane occurrence (environmental classification I M2). The frequency inverter housing MKF400.KDx is manufactured as a steel weldment with quick-release fastener. Frequency converter MFK400.KDx contains a water-cooled frequency converter - FREELOP 400 and a reversing pair of contactors used for feeding electric motors. The inverter transmits operating and fault conditions from the inverter combine and contactor set APK9U to the surface dispatching workstation, where it is possible to monitor these states on-line using a visualization program. The visualization program automatically archives the data.

FREELOP 400 frequency inverter is a voltage type with an uncontrolled rectifier fitted with IGBTs. The output voltage is modulated by sinusoidal pulse width modulation allowing maximum power utilization of the traveling electric motors of the mining harvester. The drive control is fully digital. Frequency converter MFK400.KDx has these Ex lia communication (RS422, RS485, CAN, telephone line) see the block diagram. There are two viewing windows in the JB converter chamber. Behind one viewing window is an LED display for monitoring the operating states of the contactors, their control and monitoring circuits. Behind the second viewing window is an LCD display for displaying parameters and error messages. There are five visors mounted in the door, two of them with buttons for movement on LCD and FREELOP display. In the outlet space there is an expansion tank and a filter. The frequency converter has external and internal water circuits.

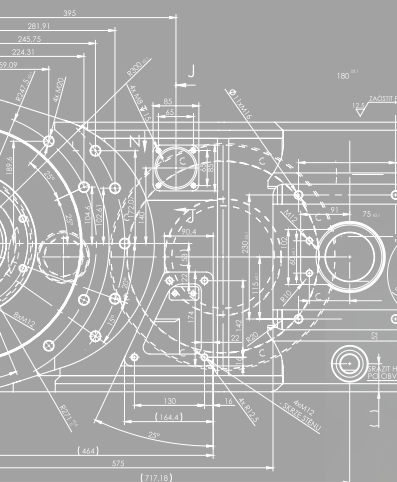

Batovka 1285
696 02 Ratíškovice
Česká republika

+420 518 391 511 [CS]
+420 518 391 607 [RU]
+420 518 391 526 [EN]
+420 518 391 590 [DE]
export@tmachinery.cz

WWW.TMACHINERY.CZ

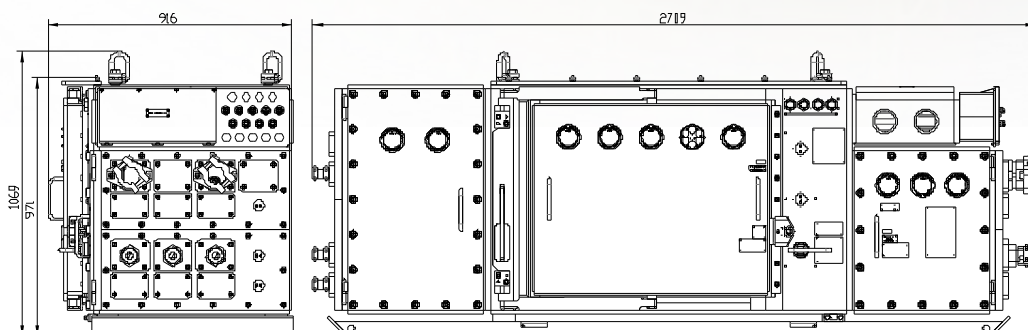



T MACHINERY
CZECH REPUBLIC

FREQUENCY CONVERTOR MFK 400.KDx

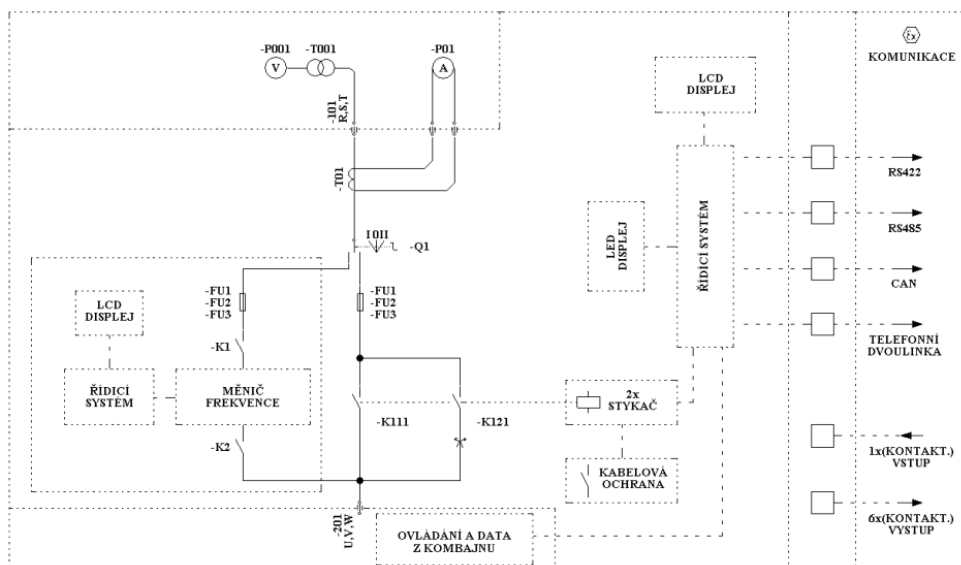

Technical parameters

Input voltage	500; 660; 1000; 1140 V/AC
Output voltage	500-1140 V/AC
Input frequency	50 Hz
Output frequency	0-200 Hz
Output 50Hz; $\cos \varphi=0,8$	336 (1140V, $\cos \varphi 0,85$) kW
Max. input current	200 A
Min. continuous output current	200 A
Max. cross section of one core of input / output cable	95 mm ²
Max. cross section of one core of JB cable	2,5 mm ²
Cooling	air/water
Water cooling connection	DN 20
Max. pressure in the outdoor cooling circuit	25 Bar
Min. flow in the outdoor cooling circuit	5 l/min.
Temperature range in the outdoor cooling circuit	5 - 25 °C
Dimension with outlets (L x H x W)	2630/3248 x 1003 x 936 mm
Weight	2300/2520 kg
Rate of protection	IP 54
Operating temperature	+5 - +40 °C
Maximum relative humidity $\pm 20^{\circ}\text{C}$	85 %

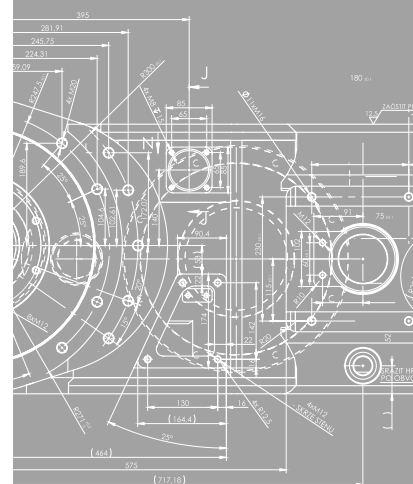

Batovka 1285
696 02 Ratíškovice
Česká republika

+420 518 391 511 [CS]
+420 518 391 607 [RU]
+420 518 391 526 [EN]
+420 518 391 590 [DE]
export@tmachinery.cz

WWW.TMACHINERY.CZ



T MACHINERY
CZECH REPUBLIC

TRANSFORMER TPK9S.x120

Transformer station TPK9S.x120 is made in explosion-proof design. Is intended for power supply of asynchronous motors and frequency converters of MFK400 series, used for power supply of electric motors of mining shearer, in underground coal mines with danger of methane occurrence (environmental classification IM2). The body of the TPK9S.x120 transformer is made as a steel weldment with quick-release.

The TPK9S.x120 transformer station is designed as a three-phase transformer and is equipped with an insulation monitoring device on its secondary side. All transformer station electrical equipment is located in a fixed enclosure. The only exceptions are intrinsically safe circuits, which are led into the outdoor environment with the risk of explosion.

The TPK9S.x120 can be operated locally using pushbuttons directly on the fixed receiver or remotely via intrinsically safe transmitter. There is a fan in the main compartment, which reduces the room temperature by forced air circulation. Transformer station TPK9S.x120 has a recorder of operational electrical quantities.

The instrument panel has 2 visors and 6 buttons. Behind one viewing window is an LED display for monitoring the operating states of the transformer, its control and monitoring circuits. The leakage resistance indicator is located after the second inspection window. With the help of buttons, the transformer can be switched on, off, tests and deblocking of the protections without the necessity to open a fixed shutter.

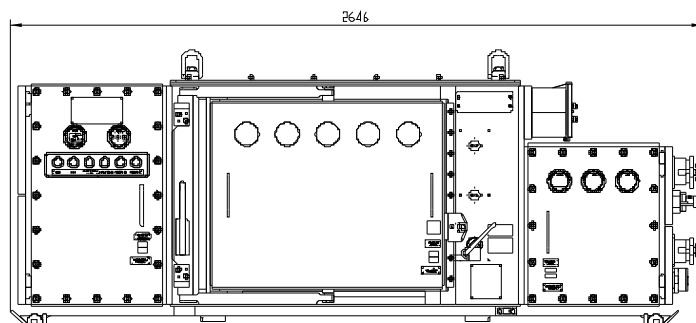
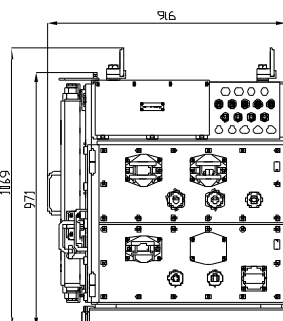
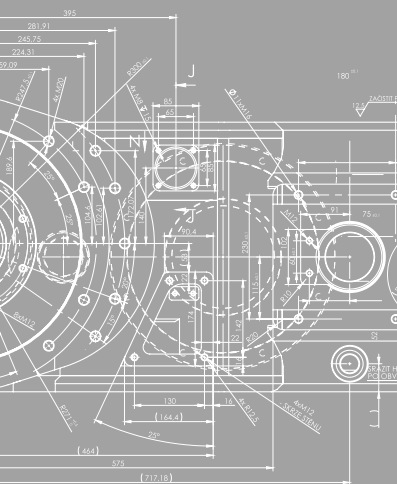

Batovka 1285
696 02 Ratíškovice
Česká republika

+420 518 391 511 [CS]
+420 518 391 607 [RU]
+420 518 391 526 [EN]
+420 518 391 590 [DE]
export@tmachinery.cz

WWW.TMACHINERY.CZ



T MACHINERY
CZECH REPUBLIC

TRAFOSTANICE TPK9S.x120

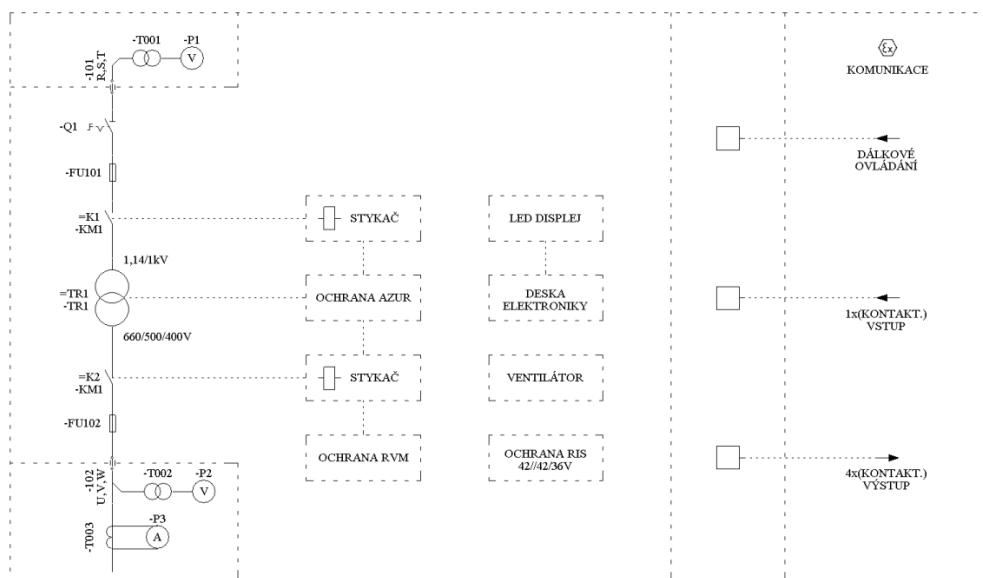

Technical parametres

Output	120 kVA
Input voltage	1 000/1 1400 V/AC
Output voltage	400 /500/660 V/AC
Output current	105 A
Voltage regulation	0, +5, +10 %
Input voltage tolerance	-20, +15 %
Short circuit voltage	1.7 %
Losses due to short circuits (ΔPCu)	955 W
Losses when running idle (ΔPFe)	605 W
Transformer efficiency	98.7 %
Number of the power cable inputs	2 pcs
Number of the power cable outputs	2 pcs
IS output/input	2 pcs
Dimension (L x H x W)	2560 x 943 x 916 mm
Weight	2 550 kg
Rate of protection	IP 54
Operation temperature	0 - +40 °C
Cooling	nternal forced air circulation

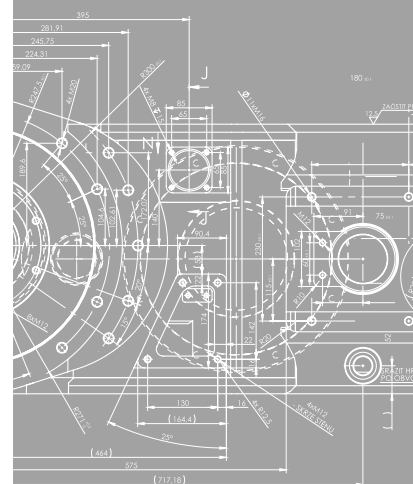

Batovka 1285
696 02 Ratíškovice
Česká republika

+420 518 391 511 [CS]
+420 518 391 607 [RU]
+420 518 391 526 [EN]
+420 518 391 590 [DE]
export@tmachinery.cz

WWW.TMACHINERY.CZ



T MACHINERY
CZECH REPUBLIC



The current trend of continuous mining requires extraction of mined minerals by belt conveyors with high transport capacity. Under-face devices of T Machinery a.s. allow for a flexible connection of the collecting scraper conveyor in the passage underneath the face with the belt conveyor so as to minimize the time lag when moving the wall conveyor drive with the progress of the face and shortening the belt conveyor.

Under-face devices up to 80 meters in length are manufactured in three versions. It depends primarily on the required volume of customer mining.



UNDER-FACE DEVICES

T Machinery a.s. produces suspended, self-supporting and elastic under-face devices.

Another benefit of the under-face devices from T Machinery a.s. is ability to place the energy train device on the side supports of the under-face conveyor. The TMD crusher (also manufactured by T Machinery) can be included into the track of under-face conveyor, which provides the required pieceage of transported mined material

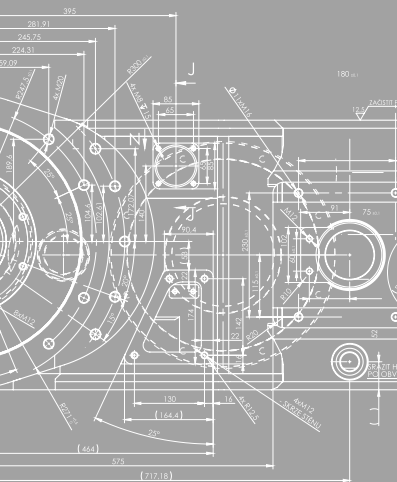

Batovka 1285
696 02 Ratíškovice
Česká republika

+420 518 391 511 [CS]
+420 518 391 607 [RU]
+420 518 391 526 [EN]
+420 518 391 590 [DE]
export@tmachinery.cz

WWW.TMACHINERY.CZ



T MACHINERY
CZECH REPUBLIC

STAGE LOADERS PZF 05

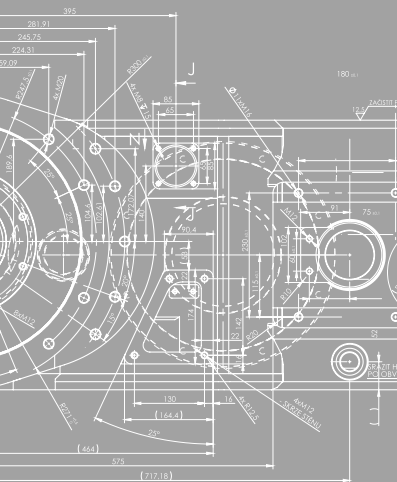
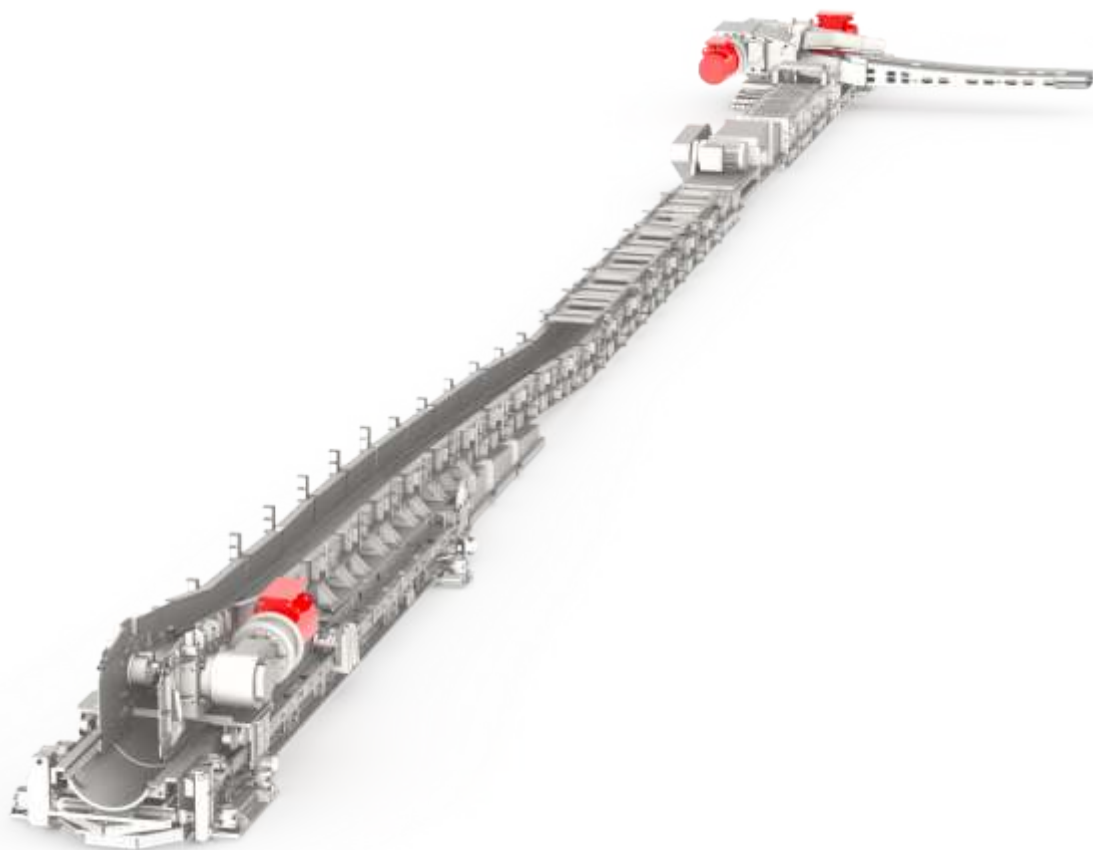

Technical parameters	PZF 05/P1	PZF 05/P2
Width of the used belt conveyor	1 000	1 000-1 200 mm
Type of the used belt conveyor	DPOF	DPOF
Width of the used scraper conveyor	228/732	225/800 mm
Power unit with hydraulics chain tensioning	DH 228/732	DH 225/800
Stretching lift	250	250 mm
Travel length of the self-supporting part	max. 12	max. 12 m
Travel step of the self-supporting part	800	800 mm
Traversing force of the equipment	120	120 t
Anchorage unit	KPD-F02	KPD-F02
Power input	200	2x200 kW
Possibility to place power station on PZF	75-100	160
Mobile power station suspended on the suspended railway	ANO	ANO
Maximum length of the conveyor	80	120 m
Performance	900	1 100 t/h

Batovka 1285
696 02 Ratíškovice
Česká republika

+420 518 391 511 [CS]
+420 518 391 607 [RU]
+420 518 391 526 [EN]
+420 518 391 590 [DE]
export@tmachinery.cz

WWW.TMACHINERY.CZ



T MACHINERY
CZECH REPUBLIC

STAGE LOADERS PZF 05

The Stage loaders PZF 05 of a self-supporting structure is a special collecting scraper conveyor. Once it is installed, it moves on the footwall of an opening and its end passes over the undercarriage and extends over the end part of the belt conveyor connected to it. The straight hydraulic motors on the travelling part of the machine produce the force necessary for this traverse. In the case where the electrical equipment is installed on the positioning plates of the under working equipment, there is no need to install the suspension railway for its operation.

The under working is equipped with grips and flexible hydraulic motors for the carrying ropes of the belt conveyors. Anchorage of the working face KPD-F 02 conveyor enables a mechanical connection between the self-supporting collecting scraper conveyor and the main drive unit of the face conveyor, which enables the PZF to move simultaneously with the working face conveyor without interrupting the working face extraction.

Technical parameters	PZF 05/P2	PZF 05/P2
Width of the used belt conveyor	1 000-1 200	1 000-1 200 mm
Type of the used belt conveyor	DPOF	DPOF
Width of the used scraper conveyor	190/800	260/852 mm
Power unit with hydraulics chain tensioning	DH 190/800	DH 260/852
Stretching lift	250	250 mm
Travel length of the self-supporting part	max. 12	max. 12 m
Travel step of the self-supporting part	800	800 mm
Traversing force of the equipment	120	120 t
Anchorage unit	KPD-F02	KPD-F02
Power input	2x200	2x250 kW
Possibility to place power station on PZF	160	160
Mobile power station suspended on the suspended railway	ANO	ANO
Maximum length of the conveyor	80	120 m
Performance	1 100	1 300 t/h

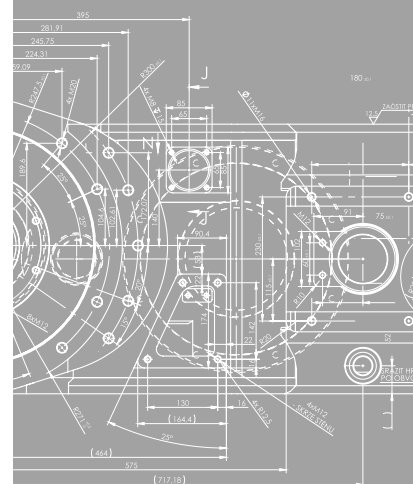

Batovka 1285
696 02 Ratíškovice
Česká republika

+420 518 391 511 [CS]
+420 518 391 607 [RU]
+420 518 391 526 [EN]
+420 518 391 590 [DE]
export@tmachinery.cz

WWW.TMACHINERY.CZ



T MACHINERY

CZECH REPUBLIC

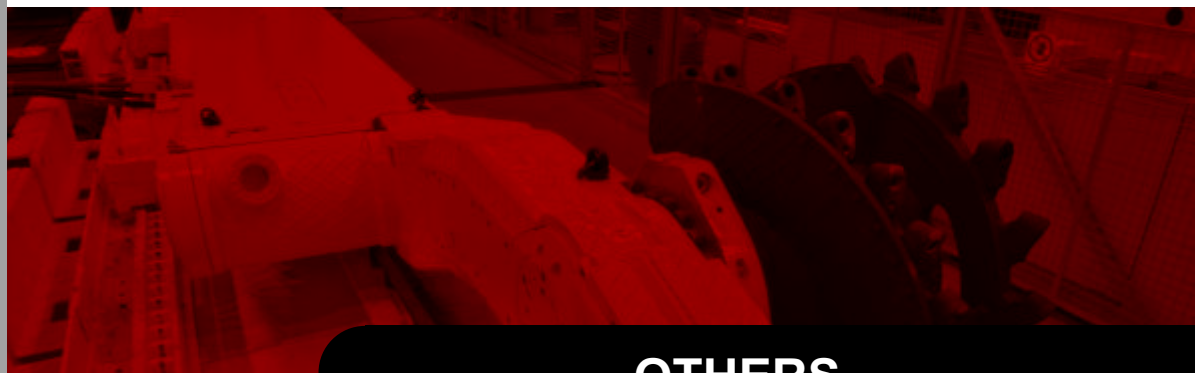

OTHERS

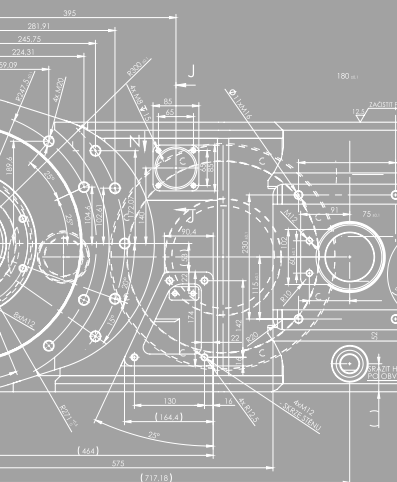

Batovka 1285
696 02 Ratíškovice
Česká republika

+420 518 391 511 [CS]
+420 518 391 607 [RU]
+420 518 391 526 [EN]
+420 518 391 590 [DE]
export@tmachinery.cz

WWW.TMACHINERY.CZ



T MACHINERY
CZECH REPUBLIC

CABLE PROTECTOR TM KUU

The TM KUU Cable Protector used in bituminous coal mines and is applicable in the SNM2 environment. The TM KUU Cable Protector is designed to shield electrical cables and water lines that lead to continuous-mining machines. It safeguards the leads against mechanical damage, protects control cables against breakdowns and prevents the lines that lead to mining machines from coiling. The TM KUU Cable Protector eliminates incidences of short circuits and similar hazards, which improves the safety of labour in coalmines. The TM KUU Cable Protector can be assembled from segments (available in several sizes) connected together to form a continuous conduit of desired length. It meets health

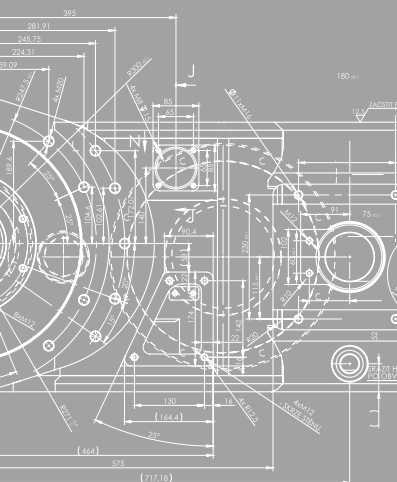
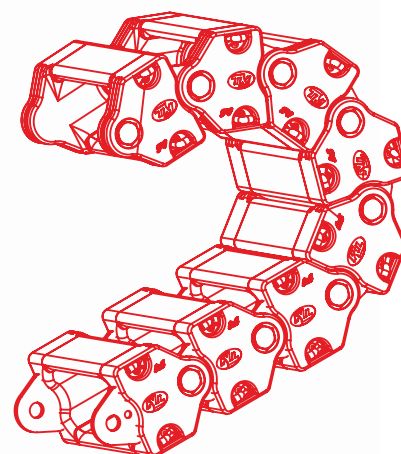
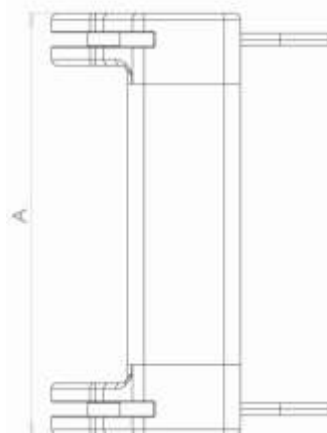

Batovka 1285
696 02 Ratíškovice
Česká republika

+420 518 391 511 [CS]
+420 518 391 607 [RU]
+420 518 391 526 [EN]
+420 518 391 590 [DE]
export@tmachinery.cz

WWW.TMACHINERY.CZ

TYPE	A	B	C	D	E	B1	
11	165	113		90	300	58	
12	210	158		90	300	58	
13	245	193		90	300	58	
21	165	113		110	390	78	mm
22	210	158		110	390	78	
23	245	193		110	390	78	



CABLE PROTECTOR TM KUO

The TM KUO Cable Protector is used in bituminous coal mines and is applicable in the SNM2 environment. It is designed to shield electrical cables and water lines that lead to continuous-mining machines. It safeguards the leads against mechanical damage, protects control cables against breakdowns and prevents the lines that lead to the mining machines from coiling. The TM KUO Cable Protector eliminates the incidents of short circuits and similar hazards, which improves the safety of labour in coalmines. The TM KUO Cable Protector can be assembled from segments (available in several Sizes) connected together to form a continuous conduit of desired length. It meets health and safety standards and requirements of safety regulations mandated in organisation engaging in underground coal mining

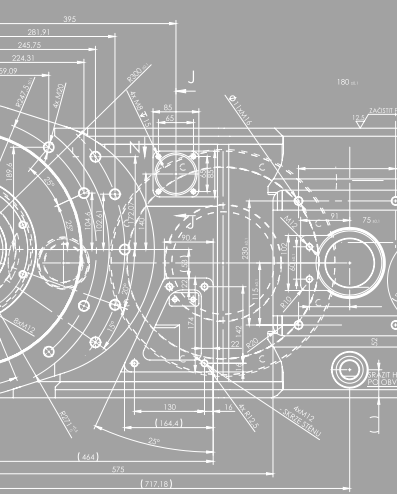
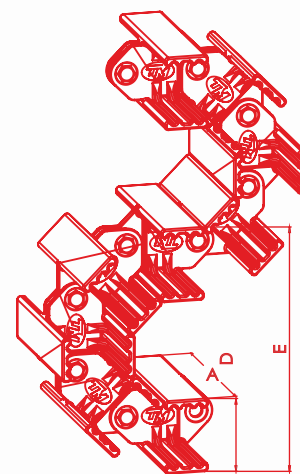
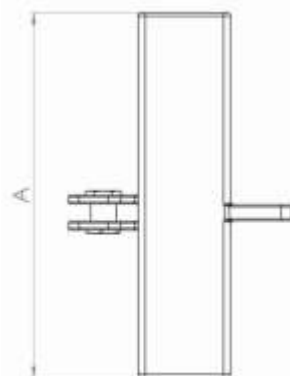
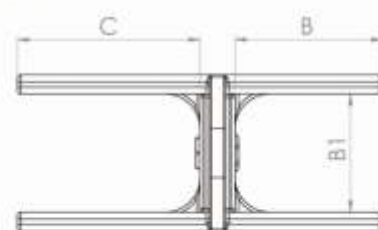
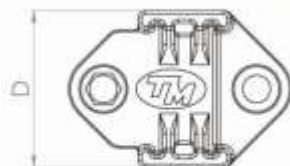
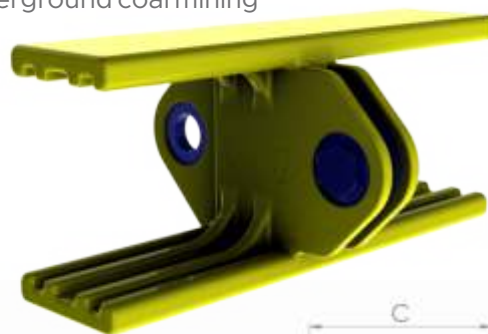

TYPE	A	B	C	D	E	B1
11	165	85	60	110	390	84
12	195	85	90	110	390	84
13	215	85	110	110	390	84
14	245	85	140	110	390	84
15	290	130	140	110	390	84
21	165	85	60	90	300	68
22	210	85	110	90	300	68
23	245	85	140	90	300	68

mm

Batovka 1285
696 02 Ratíškovice
Česká republika

+420 518 391 511 [CS]
+420 518 391 607 [RU]
+420 518 391 526 [EN]
+420 518 391 590 [DE]
export@tmachinery.cz

WWW.TMACHINERY.CZ



T MACHINERY
CZECH REPUBLIC

COAL CRUSHERS DU

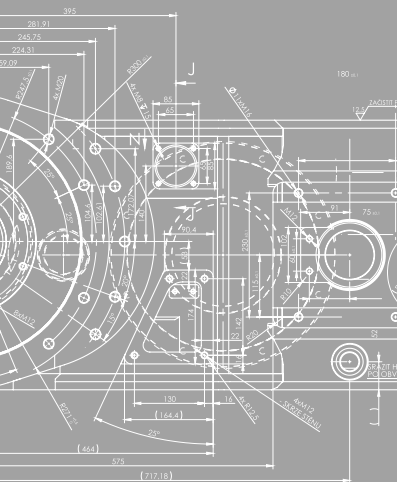
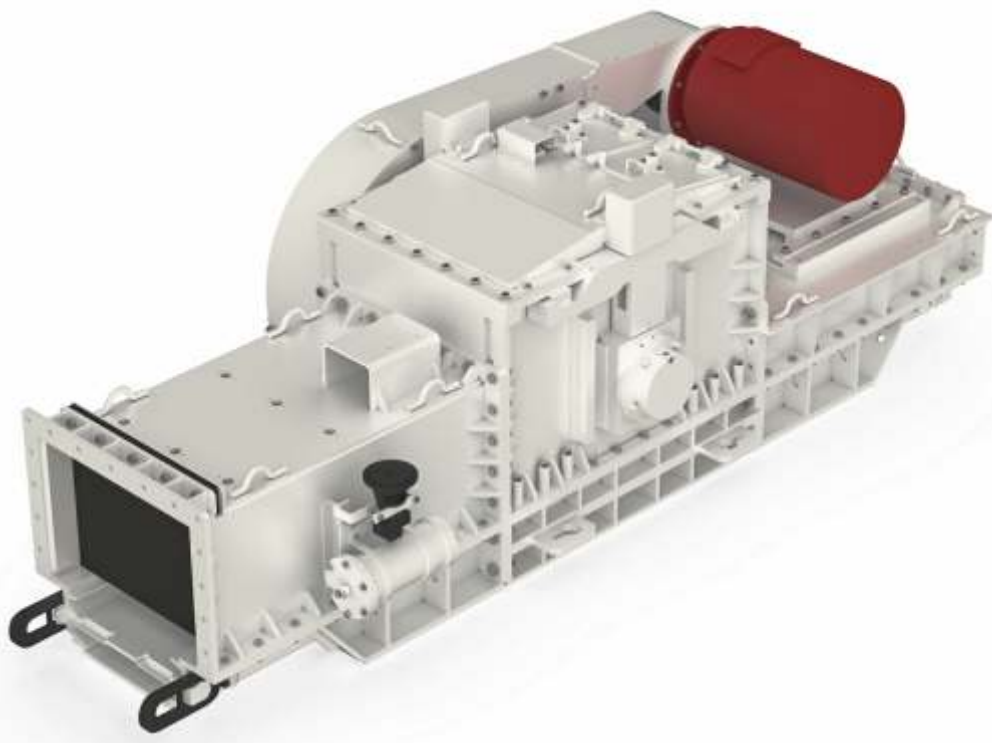

Batovka 1285
696 02 Ratíškovice
Česká republika

+420 518 391 511 [CS]
+420 518 391 607 [RU]
+420 518 391 526 [EN]
+420 518 391 590 [DE]
export@tmachinery.cz

WWW.TMACHINERY.CZ

Technical parameters	DU 1	DU 2
Capacity	1 000 - 1500	600 - 1 000 m ³ /h
Total output	100 - 160	75 - 100 kW
Crusher drum RPM	469	520 min. ¹
Max. external height	1 000	600 - 700 mm
Max. external width	900	600 - 800 mm
Max. external length	Unlimited	
Trough-gap height	190 - 340	105 - 330 mm
Height	1 870	1 250 - 1 360 mm
Width	1 830	1 640 - 1 710 mm
Length	4 500	3 000 - 4 500 mm
Weight	14 500	9 060 - 12 780 kg
Conveyor width	800 - 900	700 - 800 mm



T MACHINERY
CZECH REPUBLIC

DRTIČ UHLÍ DU

The Coal Crushers DU series was developed for crushing coal, stone or other materials having strength of up to 130 MPa. They are located in entries within the scraper conveyor line. They can be used in connection with different types of scraper conveyors, and with underface equipment.

Coal crushers DU series consist of basic parts (input, middle and output trough; input, middle and output case, middle case lid, crushing drum, drive, flywheel with friction coupling, drive cover, spraying, and automation elements); with horizontally placed crushing drum. There are 4 knife disks on the crushing drum shaft with screwed crushing bits. The machine is driven by an electric motor and it rotates a robust flywheel by means of a set of V-belts; the flywheel ensures appropriate torque for mine run crushing. Conveyor, crusher and spraying run, operational safety and device protection against damages are secured by the automatic control.

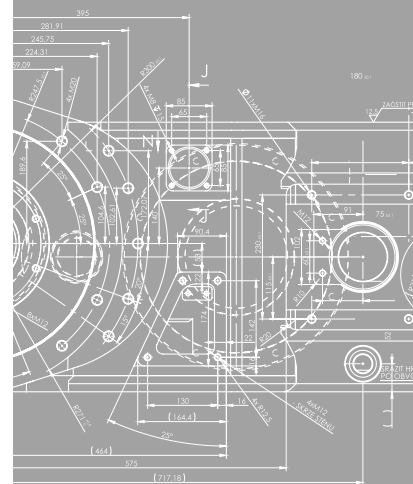
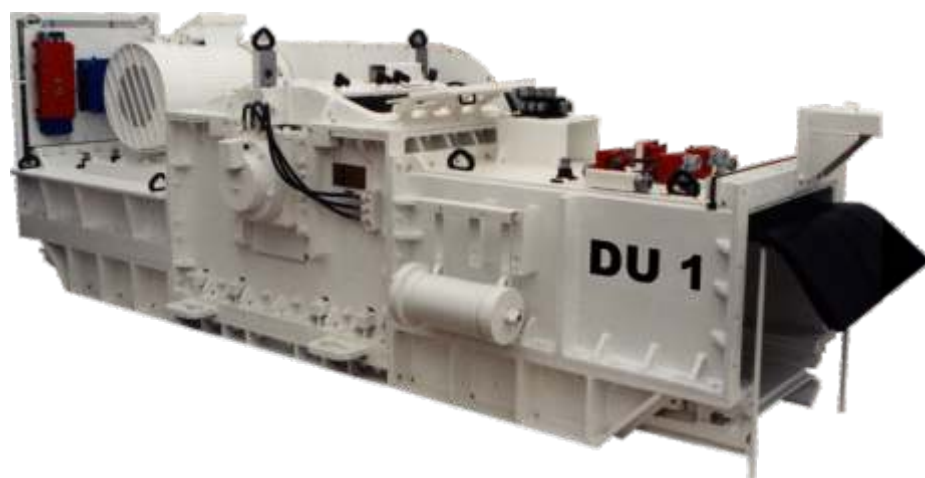

Technical parameters	DU 3	DF9/12P
Capacity	2 000	1 500 - 2 400 m ³ /h
Total output	160	160 - 250 kW
Crusher drum RPM	469	469 min. ¹
Max. external height	1 150	900 - 1 200 mm
Max. external width	1 200	1 140 - 1 200 mm
Max. external length	Unlimited	
Trough-gap height	160 - 340	160 - 340 mm
Height	1 900	1 900 - 2 200 mm
Width	2 200	2 200 - 2 300 mm
Length	4 500	4 500 - 6 000 mm
Weight	20 000	17 000 - 23 500 kg
Conveyor width	800 - 1 000	800 - 1 200 mm

Batovka 1285
696 02 Ratíškovice
Česká republika

+420 518 391 511 [CS]
+420 518 391 607 [RU]
+420 518 391 526 [EN]
+420 518 391 590 [DE]
export@tmachinery.cz

WWW.TMACHINERY.CZ



ANCHORAGE OF THE FACE CONVEYERS

The anchoring equipment KPD-F 02 is designed for the anchoring of propulsive stations of cutter stope conveyors (e.g. DH 830, Westfalia PF 4.3 HB 260 and others) at a maximum angle of 20degrees. The main circumstance for using the KPD-F 02 anchoring is for placing the cutter stope conveyor propulsive station in the corridor, under or over the stope.

Anchoring the KPD-F 02 is a block construction that enables:

- attachment of cutter stope conveyor propulsive station
- attachment of reversible station of cutter loader conveyor
- mechanical connection between cutter stope and cutter loader conveyor
- reinforcement of reversible station of cutter loader conveyor
- front and side pour-over option



Technical parameters

KPD-F 02

Maximum weight of the anchored driving station	25 000 kg
Maximum anchorage loading capacity	1 179 kN
Maximum effort to transfer anchoring incl. connection of cutter stope conveyor with cutter loader conveyor	2 x 500 kN



Technical parameters

KPD-TM

Maximum weight of the anchored driving station	25 000 kg
Maximum anchorage loading capacity	1 179 kN
Maximum effort to transfer anchoring incl. connection of cutter stope conveyor with cutter loader conveyor	2 x 500 kN

Mutual rotation of stations: in a vertical plane from -12 ° to + 12 °in horizontal ± 10 °

The height of the transfer point (from the beginning) is 518 - 1118 mm

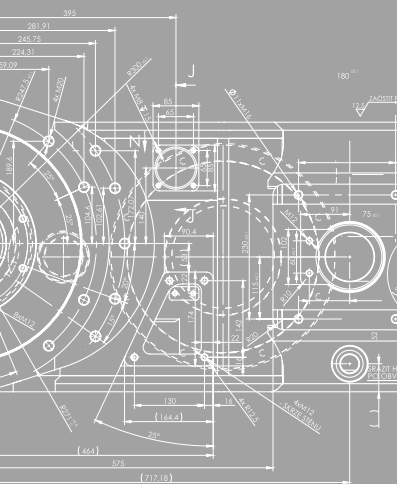

Batovka 1285
696 02 Ratíškovice
Česká republika

+420 518 391 511 [CS]
+420 518 391 607 [RU]
+420 518 391 526 [EN]
+420 518 391 590 [DE]
export@tmachinery.cz

WWW.TMACHINERY.CZ



T MACHINERY
CZECH REPUBLIC

BELT TRANSPORT IN UNDERGROUND MINES

T Machinery a.s. has manufactured equipment for mines and bulk material handling. T Machinery a.s. has supplied complete transport lines for bulk material and personnel transport. We offer conveyors with belt width 800, 1000, 1200, 1400 and 1600 mm. Most of them have length from 50 to 1500 m and power from 50 to 1260 kW.

Conveyor assembly recommended to customers reflects the mining conditions and limited space is available. The particular location and dimension of drive unit, transfer points, take up etc. is made according to configuration of transport line, its inclination, space restrictions and crossing with monorails. The project of transport line is worked out taking into account standards ISO, EN or GOST.

The advantage of our mine belt conveyors are lower space required and very rigid structure. We use proven technical concepts introduced in the Czech mining industry, which is characterized by diverse mining and geological conditions. Drive units have rubber lagged pulleys with diameter 630 to 1500 mm with external or internal bearings. Most of the driving units use air cooled electric motors up to 4 x 315 kW. Nevertheless, much stronger drive units can be installed using water cooled electric motors. Take up station with belt storage are composed from sections so necessary length for particular length of conveyor is achieved. Pneumatic, electric or hydraulic power is used to stretch the belt. The take up pulley travel and force are influenced by conveyor length and belt modulus. Conveyor structure use channel stringers or ropes as a carrying means for idlers. Diameter of rolls varies from 89 mm for lower capacity belts to 159 mm for high speed and capacity. Rolls are located on side of idler so the cut of belt by rolls support cannot be the case. Very important members of transport line are transfer points. Transfer points design significantly influences wear life of the belt.

The design of transfer points requires careful study of the vertical and horizontal distance between conveyors and their angle of intersection. Nearly every transfer point is tailor-made. Nearly all mining conveyors are remote controlled, accessories used for safety and automatic control (especially temperature), data collection, diagnostic etc. are being widely used.

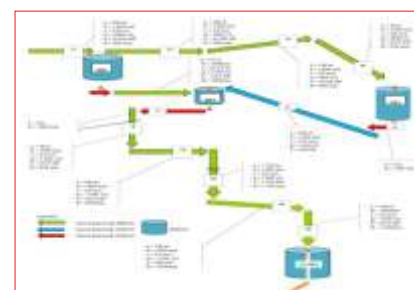
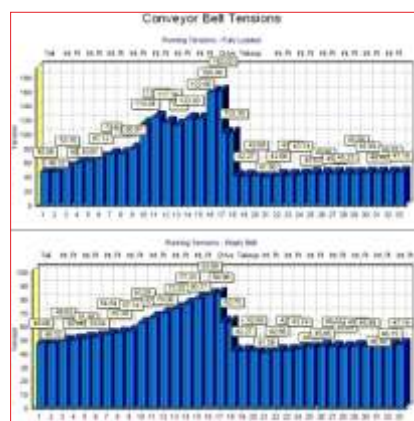
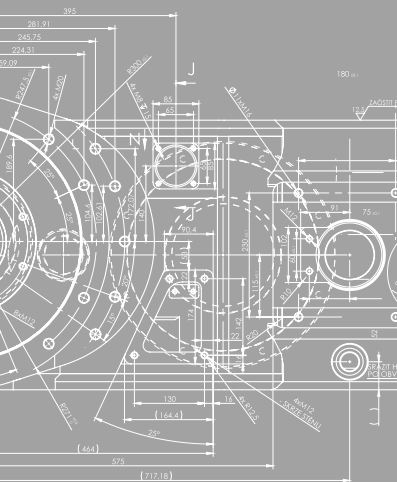

Batovka 1285
696 02 Ratíškovice
Česká republika

+420 518 391 511 [CS]
+420 518 391 607 [RU]
+420 518 391 526 [EN]
+420 518 391 590 [DE]
export@tmachinery.cz

WWW.TMACHINERY.CZ

Technical parameters

Belt width	800	1000	1200	1400	1600	mm
Transport capacity	300-1000	500-1500	1000-3000	1500-4500	2000-5000	t/h
Drive pulley diameter	630-1030					mm
Installed power	50-1260					kW



T MACHINERY
CZECH REPUBLIC

CONSTANT TENSION TAKE-UPS AND BELT STORAGE

Powered mechanisms: pneumatic, hydraulic, gravity or electric winch. Belt storage, number of sections according to total length of conveyor. Sectional design, length of section 3 m.

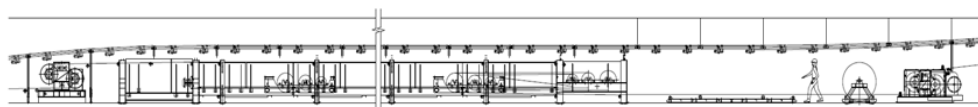

BELT TRANSPORT FOR SURFACE OPERATIONS

T Machinery a.s. has provided engineered solutions for many of bulk material handling applications in power plants, ports etc. Typically, we make several site visits to meet with engineering and operations personnel to create project specifications.

The product range also comprises of Structural Engineering, Services, Conveyor Galleries, Towers and Trestles including Engineering Design Services Drawings as per EN, ISO, Eurocode or DIN 18800.



Technical parameters

Belt width	800 - 2 200	mm
Transport capacity	250 - 16 000	t/h
Drive pulley diameter	500 - 2 000	mm
Installed power	37 - 4 000	kW

Batovka 1285
696 02 Ratíškovice
Česká republika

+420 518 391 511 [CS]
+420 518 391 607 [RU]
+420 518 391 526 [EN]
+420 518 391 590 [DE]
export@tmachinery.cz

WWW.TMACHINERY.CZ



UNDERGROUND BELT CONVEYORSDRIVE UNITS

With external bearings of drive pulleys

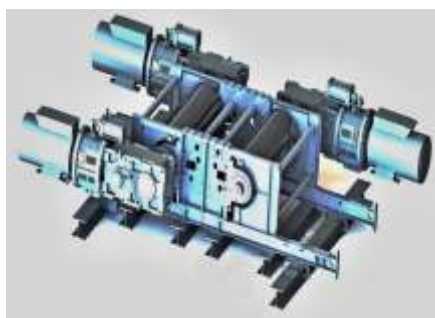

Technical parameters

Number of electric motors	1 - 4
Power of one air cooled electric motor	37 - 315 kW
Power of one water cooled electric motor	až 500 kW
Gearboxes	according to the recommendations
Soft start or frequency control including automation	
Breaks	pneumatic, electric, hydraulic

TRANSFER STATIONS TECHNOLOGY

Tailor-made belt conveyor transfer stations of various types allow steady, efficient transfer of extracted materials from upstream on downstream conveyor. Feeders, chutes and drag conveyor. Outlets chute into the bunker

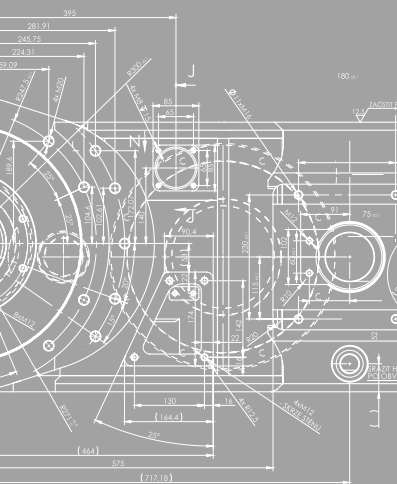

Batovka 1285
696 02 Ratíškovice
Česká republika

+420 518 391 511 [CS]
+420 518 391 607 [RU]
+420 518 391 526 [EN]
+420 518 391 590 [DE]
export@tmachinery.cz

WWW.TMACHINERY.CZ



FLOOR -MOUNTED OR ROOF-HUNG BELT STRUCTURE

Rigid structure – the easy-to-install section of the structure composes of two stringers, one return idler and three carrying idlers. Sections can be floor-mounted or roof-hung.

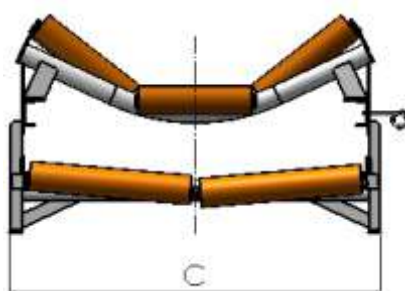

Wire rope structure with rigid idlers – wire rope structures use two parallel ropes anchored at both sides and roof-hung or floor mounted. Carrying and return idlers are wedged on the ropes.

Wire rope structure with garland rollers – wire rope structures use two parallel ropes anchored at both sides and roof-hung or floor mounted. Carrying and return three roller garlands are hung on the rope structure.

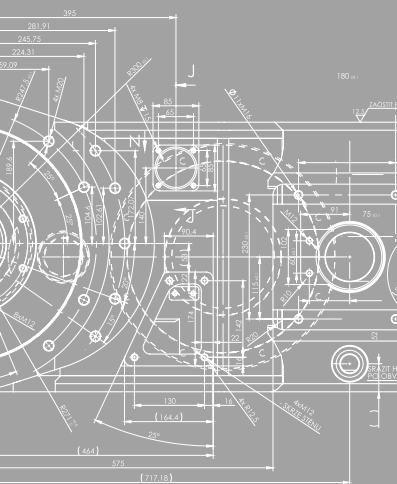
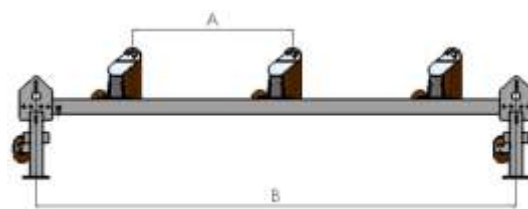

Batovka 1285
696 02 Ratíškovice
Česká republika

+420 518 391 511 [CS]
+420 518 391 607 [RU]
+420 518 391 526 [EN]
+420 518 391 590 [DE]
export@tmachinery.cz

WWW.TMACHINERY.CZ

Belt width	Length of structure section B	Roller diameter	Width of rigid structure C	Ropes spacing C	Carrying idler spacing A
mm	mm	mm	mm	mm	mm
800		108/127/133	1100	1150/1100	
1000		108/127/133	1370	1300/1250	
1200	3/3,75	108/127/133	1590	1550/1500	1/1,25/1,5
1400		133/159	1726	1750/1680	
1600		159	1970		



T MACHINERY
CZECH REPUBLIC

MINE TRAILER LOCOMOTIVE BIZON

The Mine Trailer Locomotive BIZON 120-X type is a means of traction designed for the transportation of train sets on one-rail suspended railways, which use running section I 155 in horizontal plane and in dips of up to 30 degrees. The Mine Trailer Locomotive BIZON 120-X consists of the motor component, two cabins and 4 to 6 drive units (as required by the customer). The motor component consists of a Perkins 1104 diesel motor and hydraulic aggregate, with the capacity of the main hydraulic pump being 125 ccm or 180 ccm. The drive units are furnished with low-speed for transferring the tractive force of the locomotive on the running path profile. Each drive unit is also furnished with braking equipment ensuring steady braking of the train. The electric outfit ensures a high level of operational safety of the Mine Trailer Locomotive BIZON 120-X.

Transmitters and electronic systems monitor the motor working conditions, the locomotive speed and other values that have an important influence on safety. In case follow-up parameters are exceeded, the locomotive is stopped and the motor is turned off. All data are saved in the system's memory. The Mine Trailer Locomotive BIZON 120-X is designed in compliance with Provision no. 23/2003 and 24/2003 Coll, as amended, the guidelines of CSB no. 22/1989 Coll. and other related rules and standards. It is a piece of equipment designed for compliance within the 1-st category M2, in accordance with the directive EU 94/9 ATEX and meets the requirements of the EU Council directive 98/37/EU.

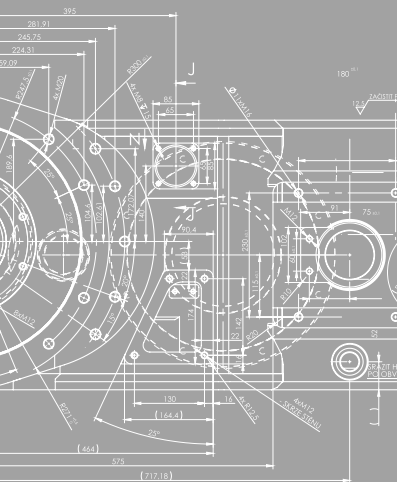

Technical parameters

Kind of motor	ignition with direct fuel injection
Total output	93 kW
Nominal voltage	24 V
no. of drivers	4,5 nebo 6
Haulage pull	80 - 120 kN
Dimensions (w x h x l)	800 - 1200 - 9850, 11 050, 12 250 mm
Max. line inclination	30 °
Max. speed	7,6 km/h
Weight	4 650 - 5 500 kg

Batovka 1285
696 02 Ratíškovice
Česká republika

+420 518 391 511 [CS]
+420 518 391 607 [RU]
+420 518 391 526 [EN]
+420 518 391 590 [DE]
export@tmachinery.cz

WWW.TMACHINERY.CZ



T MACHINERY
CZECH REPUBLIC

MOBILE POWER STATIONS

Mobile Power Stations are used for the conveyance of suspension and electrical equipment, parallel to the working face or extracted opening.

The conveyance of suspended electrical equipment on a suspension railway

The transformers and contactors suspensions are made in various designs that enable them to be attached to any transformer or in any simple way to facilitate it simultaneously with the mobile power station, while using the manipulation suspension railway that is an integrated part of the under working face equipment. The cable transport frames-serve as a temporary cable position while they either wind up or unwind depending on the way of use. Mostly these frames are on railways in front of the Mobile Power Station, and connected to a flexible cable line and suspended stepping equipment.

Conveyances for positioning the equipment onto the under-working face equipment

These are the frames for the transformers, contactors etc. They serve to attach this equipment directly onto the under-working face collecting flight conveyor line and they are transferred simultaneously with the PZF.

Advantages of Mobile Power Station:

- Compatible with all electrical equipment currently being used
- Minimum building height, which ensures space for maintenance and repairs on the equipment
- Resolves the problem of varying pitches of the opening
- All electrical equipment is moved together with the working face advance
- In the case of a small opening height, the Mobile Power Station can be placed on the setting-up PZF plate

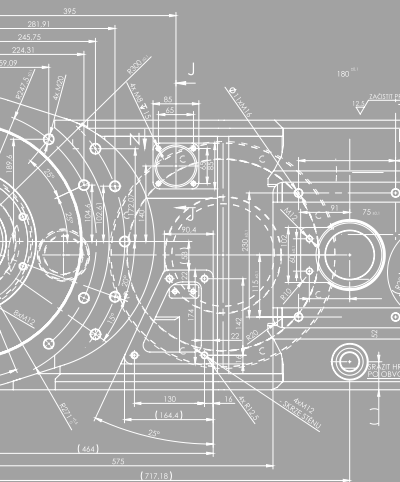

Batovka 1285
696 02 Ratíškovice
Česká republika

+420 518 391 511 [CS]
+420 518 391 607 [RU]
+420 518 391 526 [EN]
+420 518 391 590 [DE]
export@tmachinery.cz

WWW.TMACHINERY.CZ



TESTING ROOM TM

The company for type and piece testing of produced mining devices. T Machinery a.s. has a new testing polygon, primarily determined A basic component of the testing room is a new transformer station providing a wide range of supply voltage.

The motor load and gear system can be done with the help of two asynchronous dynamometers recuperating energy from the testing system back to the power supply network. Both dynamometers are equipped with digital control unit enabling operation in drive regime or load and revolution or moment coupling. The control unit is connected to a PC that programmed for analysis and measured



Available power supplies for testing devices:

Nominal voltage (V)	Nominal output (kVA)	Nominal frequency (Hz)	Regulation of nominal voltage(%)	Electric system
400/500/600	120	50	-5, -10	IT
660	150	0 - 320	180 V až 690 V	IT
1000/1140	630	50	-20 až +25	IT
3300/6000	2500	50	-20 až +25	IT

Working features of dynamometer ASD P153 (leÖ) and dynamometer ASD P500

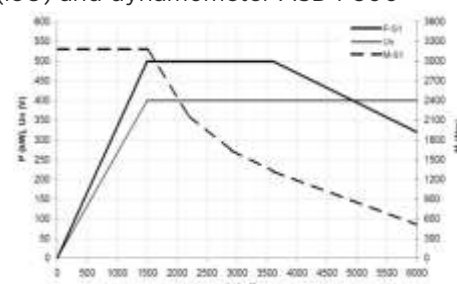
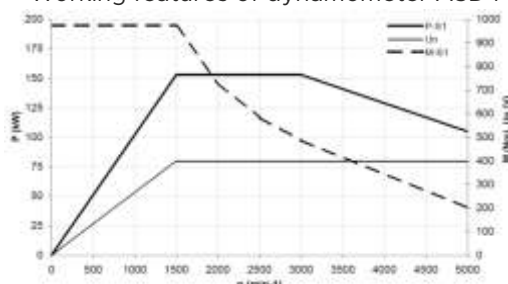

Technical parameters of dynamometers:

Parameter	Dynamometr ASD P153	Dynamometr ASD P500
Nominal output	153	500 kW
Revolutions	1 500 - 3 000	1 500 - 3 600 min ⁻¹
Moment	974 - 482	3 182 - 1 326 Nm
Maximal revolutions / power	5 000/105	6 000/320 min ⁻¹ /kW

Batovka 1285
696 02 Ratíškovice
Česká republika

+420 518 391 511 [CS]
+420 518 391 607 [RU]
+420 518 391 526 [EN]
+420 518 391 590 [DE]
export@tmachinery.cz

WWW.TMACHINERY.CZ



T MACHINERY
CZECH REPUBLIC

TESTING ROOM TM

Dynamometer ASD P153 is placed onto a fixed base. The device loaded herewith is anchored to a lifting table with dimensions 1000 x 1500 mm and lifting capacity 1 500 kg. Dynamometer ASD P500 is placed onto a cast-iron clamping plate embedded into the floor that has dimensions 4500 x 6300 mm. The testing device is clamped to the same plate and supported to the same axial height with the dynamometer. A gantry crane moving over the testing room with a lifting capacity of 25000 kg is designed for handling burdens.

The testing room is equipped with a precise performance-related analyser YOKOGAWA WT 1800 by the help of an external converter with a three-phase measurement of current up to 1000 A. The testing room is further equipped with a 16 channel mobile temperature measurement unit (12x sensor Pt100, 4x K type thermoelement). The unit enables measurement of temperatures in the range from 0 to 200 C. When using thermoelements it is possible to measure temperatures directly onto live parts, up to a voltage of 660 V.

For cooling of tested devices the testing room is equipped with its own cooling aggregate that is independent of the public water pipeline. This cooling aggregate has total two circuits. The first circuit is an open circuit that uses water, with a maximum flow of 200 l/min at maximum pressure of 2.75 Mpa. The second circuit is a closed one with anticorrosive coolant. This one has maximum flow of 50 l/min and maximum pressure of 1.2 Mpa. The company T Machinery a.s. offers both processing of technical tests according to the customer's own requirements, and also direct leasing of the whole working place to the professional public.

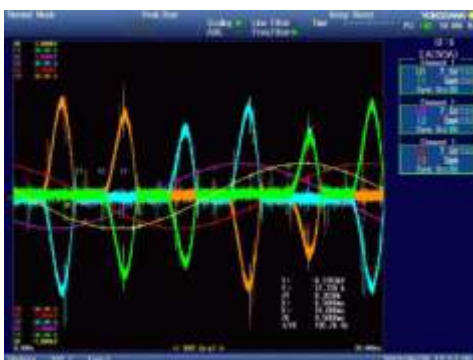

Phase	U ₁	U ₂	U ₃	I ₁	I ₂	I ₃	P ₁	P ₂	P ₃	P _Σ	Q ₁	Q ₂	Q ₃	Q _Σ	cos φ
U1	230.00	230.00	230.00	0.000	0.000	0.000	0.000	0.000	0.000	0.000	0.000	0.000	0.000	0.000	1.000
U2	230.00	230.00	230.00	0.000	0.000	0.000	0.000	0.000	0.000	0.000	0.000	0.000	0.000	0.000	1.000
U3	230.00	230.00	230.00	0.000	0.000	0.000	0.000	0.000	0.000	0.000	0.000	0.000	0.000	0.000	1.000
I1	0.000	0.000	0.000	0.000	0.000	0.000	0.000	0.000	0.000	0.000	0.000	0.000	0.000	0.000	1.000
I2	0.000	0.000	0.000	0.000	0.000	0.000	0.000	0.000	0.000	0.000	0.000	0.000	0.000	0.000	1.000
I3	0.000	0.000	0.000	0.000	0.000	0.000	0.000	0.000	0.000	0.000	0.000	0.000	0.000	0.000	1.000
P1	0.000	0.000	0.000	0.000	0.000	0.000	0.000	0.000	0.000	0.000	0.000	0.000	0.000	0.000	1.000
P2	0.000	0.000	0.000	0.000	0.000	0.000	0.000	0.000	0.000	0.000	0.000	0.000	0.000	0.000	1.000
P3	0.000	0.000	0.000	0.000	0.000	0.000	0.000	0.000	0.000	0.000	0.000	0.000	0.000	0.000	1.000
PΣ	0.000	0.000	0.000	0.000	0.000	0.000	0.000	0.000	0.000	0.000	0.000	0.000	0.000	0.000	1.000
Q1	0.000	0.000	0.000	0.000	0.000	0.000	0.000	0.000	0.000	0.000	0.000	0.000	0.000	0.000	1.000
Q2	0.000	0.000	0.000	0.000	0.000	0.000	0.000	0.000	0.000	0.000	0.000	0.000	0.000	0.000	1.000
Q3	0.000	0.000	0.000	0.000	0.000	0.000	0.000	0.000	0.000	0.000	0.000	0.000	0.000	0.000	1.000
QΣ	0.000	0.000	0.000	0.000	0.000	0.000	0.000	0.000	0.000	0.000	0.000	0.000	0.000	0.000	1.000
cos φ	1.000	1.000	1.000	1.000	1.000	1.000	1.000	1.000	1.000	1.000	1.000	1.000	1.000	1.000	1.000

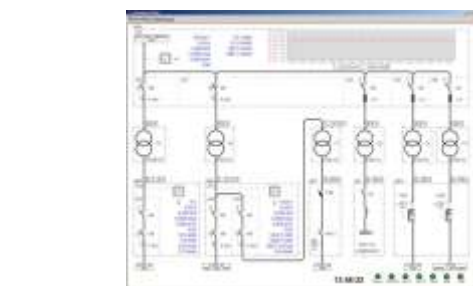
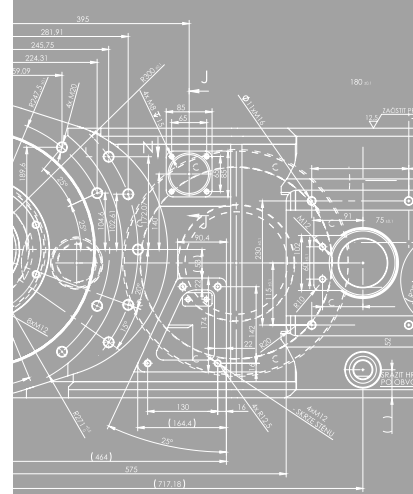

YOKOGAWA 1800WT

Batovka 1285
696 02 Ratfškovice
Česká republika

+420 518 391 511 [CS]
+420 518 391 607 [RU]
+420 518 391 526 [EN]
+420 518 391 590 [DE]
export@tmachinery.cz

WWW.TMACHINERY.CZ

REFERENCES

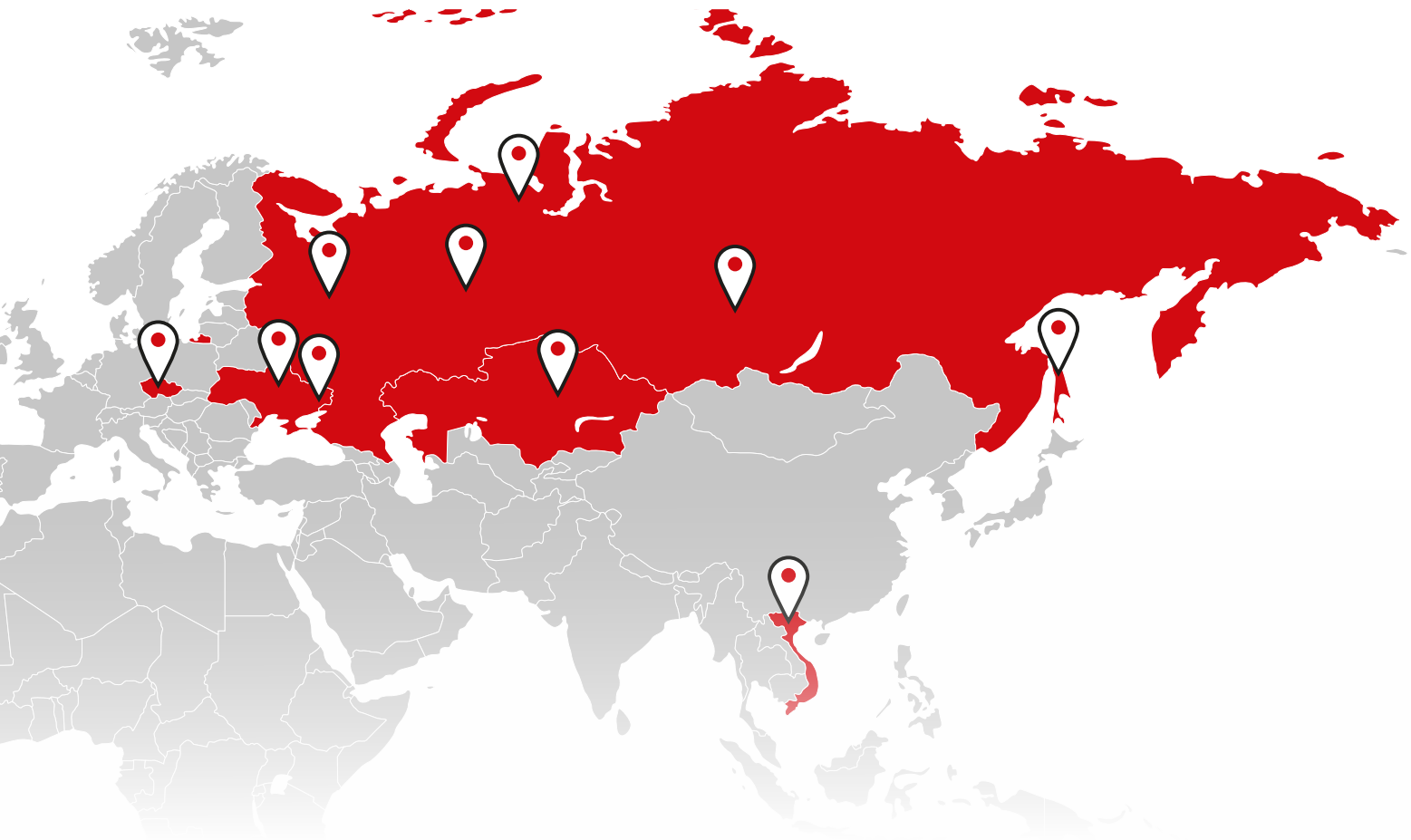

HISTORY

It was the year 1940, when Mr. Benda, the head of the plant engineering at Tomáš Mine, got an idea while point-sharpening a pencil. He noticed two tiny cutters running around the pencil and sharpening it into a cone with their bits. What about adapting something similar in order to be able to mill coal! Together with the head of mining design office Mr. Moravec, they designed and made a circular road header, which was a major step forward in mining technology.



1940



1992



2018