



Range DN: 6 ~ 500



Range PN: 10 ~ 100



PED 97/23/EC
PED 2014/68/EU



TR TS 10/11,
12/11, 32/11



EN 12 569
CERTIFICATE



CERTIFICATE
API 607, 6FA

Operating temperature: -196 °C ~ 550 °C

Connection into piping: Flanged, welded ends, threaded ends, combined execution

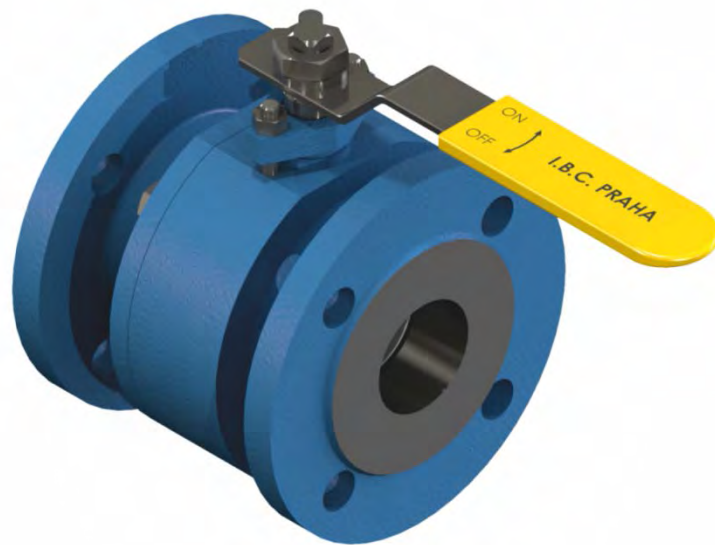

DESCRIPTION

K81 (floating ball) valves are controlled shut-off valves. They are designed to stop or allow the flow of the medium by external operation, either manually or via the installed drive. The ball valves allow the medium to flow in both directions. Their construction is designed to prevent the build-up of sediment in the flow channel, which would otherwise hinder the valve operation. These ball valves are designed and manufactured to ensure maximum service life and reliability.

MATERIAL SPECIFICATION

K81 ball valves are made from carbon, alloy and stainless steels. The material type can be adjusted according to the customer's request to optimally suit the operating conditions.

APPLICATION

K81 ball valves are suitable for various liquids, gases and steam.

BASIC STANDARDS FOR DESIGN

Basic design

EN 1983

Pressure-temperature rating

EN 12 516 - 1

Testing

EN 12 266 - 1, 2

Face-to-face dimensions

EN 558, EN 12 982

Dimensions of the welded ends

EN 12 627

Top Flange dimensions

EN ISO 5211

Flange dimensions

EN 1092 - 1

Special

NACE MR-0175

BALL VALVES

TYPE K81

STRUCTURAL DESIGN

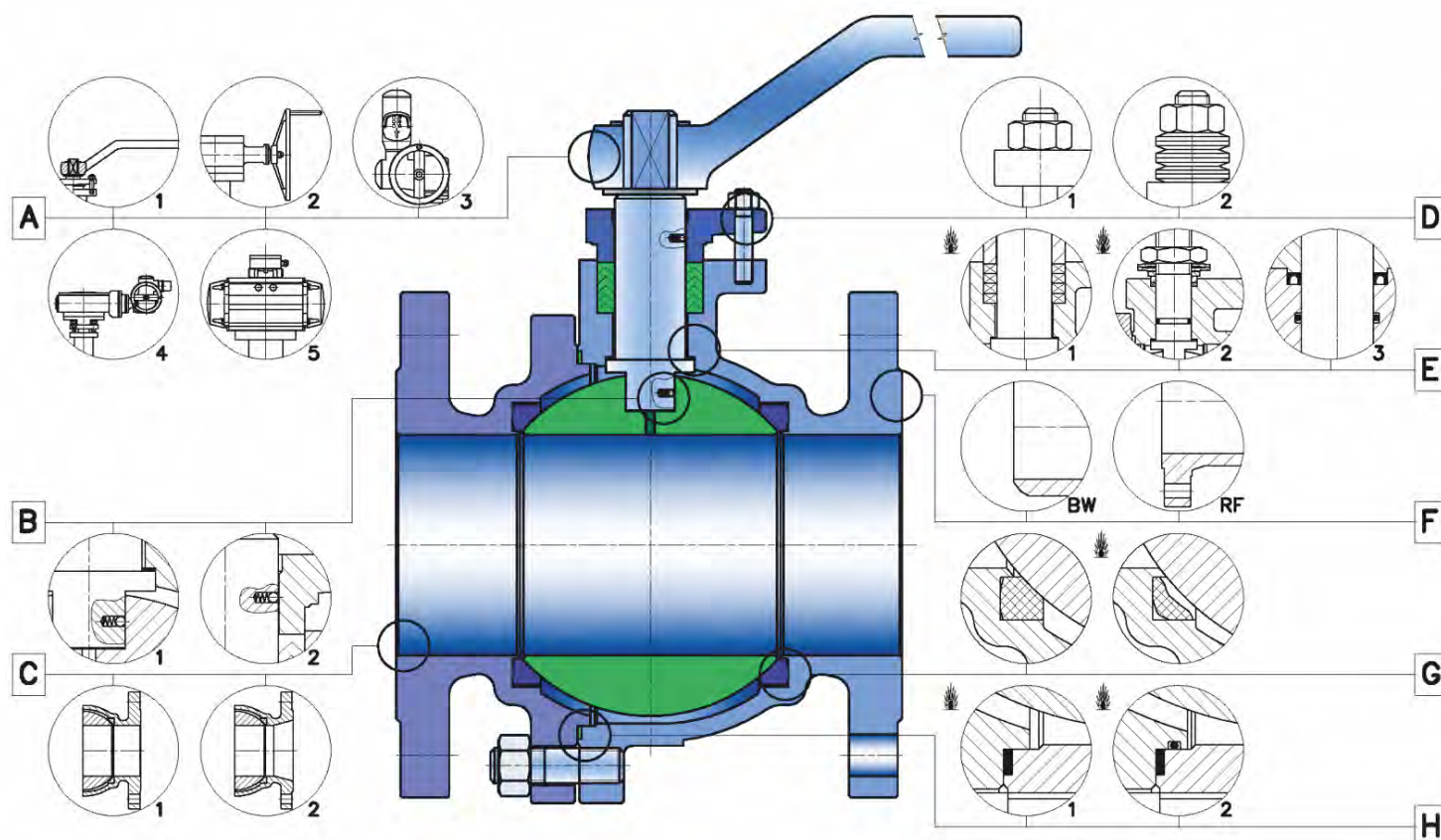

A - Control

- by hand lever
- gear box+hand wheel
- electric actuator
- electric actuator+gear box
- pneumatic actuator

B – Antistatic execution

- . is solved by using springs and small balls. The ball is electrically connected with the control stem. The control stem is electrically connected with the body

C – Flow direction

- . straight,full bore
- . straight,reduced bore

D - Gland compression

- in case of valve operation with cyclic changes in pressure or at high pressures and temperatures, the gland compression by means of Belleville springs, which secure a constant pre-stress in packing, is preferred

E – Stem packing

- by graphite packing in compliance with Fire safe design
- by PTFE packing
- by O – ring and graphite ring, according to Fire safe design
- by O – ring and PTFE V-shaped ring packing

F – Connection into piping

- flanged
- welded
- socket welding
- threaded
- welded-ends according to customer's requirements

G- Execution of the seats

- execution of the seats meets the requirements of Fire safe design, i.e. in case of burnout seat ring, the tightness of the closure is secured by sealing of the ball against metal seat – there is metal to metal connection.

H – Bonnet sealing

- executed by sealing ring or a combination of sealing and O-ring. To comply with Fire safe design is used graphite seal ring, moreover body and cover are sealed by metal to metal

BALL VALVES

TYPE K81

MATERIAL SPECIFICATION

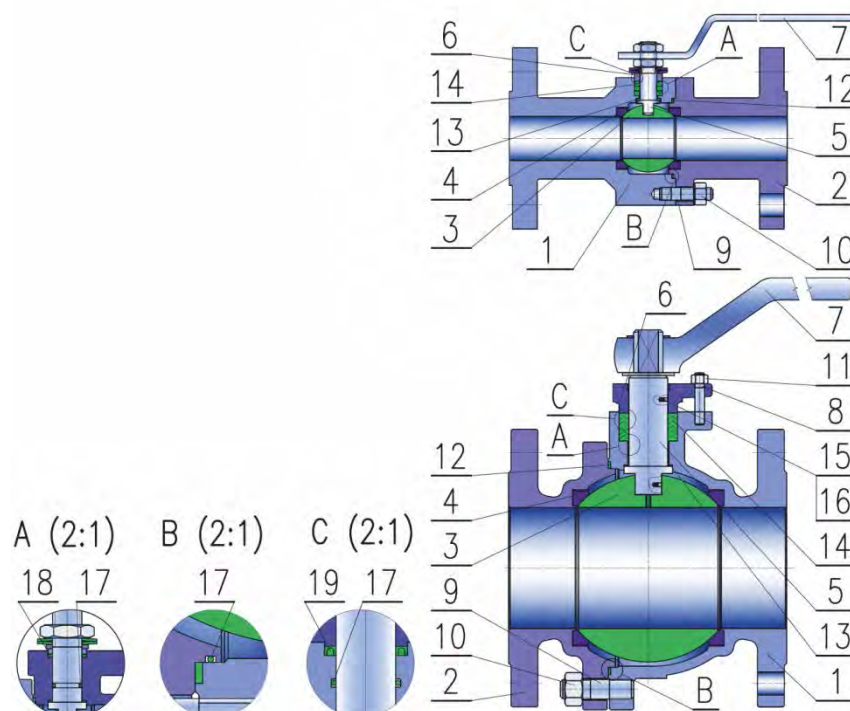

Pos.	Designation	FOUNDRY EXECUTION						FORGED EXECUTION					
		WCB	LCB/LCC	CF3	CF3M	CF8	CF8M	A350 LF2	A105	1.4551	F316L	F304	F316
1	Body	A216 WCB	A352 LCB, LCC	A351 CF3	A351 CF3M	A351 CF8	A351 CF8M	A350 LF2	A105	1.4541	A182 F316L	A182 F304	A182 F316
2	Bonnet	A216 WCB	A352 LCB, LCC	A351 CF3	A351CF3M	A351 CF8	A351 CF8M	A350 LF2	A105	1.4541	A182 F316L	A182 F304	A182 F316
3	Ball	A105 + ENP (Cr), A350 LF2 + ENP (Cr), A182 F304, A182 F316	A352 LCB, LCC + ENP (Cr) A182 F304, A182 F316	A351 CF3, A182 F304L	A351 CF3M, A182 F316L	A351 CF8, A182 F304	A351 CF8M, A182 F316	A350 LF2 + ENP (Cr)	A105 + ENP (Cr)	1.4541	A351 CF3M, A182 F316L	A351 CF8, A182 F304	A351 CF8M, A182 F316
4	Seat	PTFE, PTFE+ glass, PTFE + graphite, PTFE + stainless steel, PEEK, A182 F304, A182 F304L, A182 F316, A182 F316L											
5	Pin	A182 F6a	A182 F6a	A182 F304L	A182 F316L	A182 F304	A182 F316	A182 F6a	A182 F6a	1.4541	A182 F316L	A182 F304	A182 F316
6	Gland Flange	A216 WCB	A352 LCB, LCC	A351 CF3	A351 CF3M	A351 CF8	A351 CF8M	A350 LF2	A105	1.4541	A182 F304L	A182 F304	A182 F316
7	Lever	carbon steel											
8	Bolt	A193 B7	A320 L7	A193 B8	A193 B8M	A193 B8	A193 B8M	25CrMo 4	A193 B7	A2-70	A193 B8M	A193 B8	A193 B8M
9	Bolt	A193 B7	A320 L7	A193 B8	A193 B8M	A193 B8	A193 B8M	25CrMo 4	A193 B7	A2-70	A193 B8M	A193 B8	A193 B8M
10	Nut	A194 2H	A194 4	A194 8	A194 8M	A194 8	A194 8M	A2-70	A194 2H	A2-70	A194 8M	A194 8	A194 8M
11	Nut	A194 2H	A194 4	A194 8	A194 8M	A194 8	A194 8M	A2-70	A194 2H	A2-70	A194 8M	A194 8	A194 8M
12	Gasket	graphite, PTFE, PTFE+ glass, PTFE + graphite, PTFE + stainless steel											
13	Washer	PTFE, PTFE+ glass, PTFE + graphite, PTFE + stainless steel, bronze											
14	Gland Packing	graphite, PTFE, PTFE+ glass, PTFE + graphite, PTFE + stainless steel											
15	Spring	Stainless steel											
16	Small Ball	Stainless steel											
17	O - Ring	NBR, HNBR, EPDM, VITON, VITON GLT, SI											
18	Seal	graphite											
19	Sealing Ring	PTFE, with PTFE filler + spring from stainless steel											

BALL VALVES

TYPE K81

DIMENSIONS

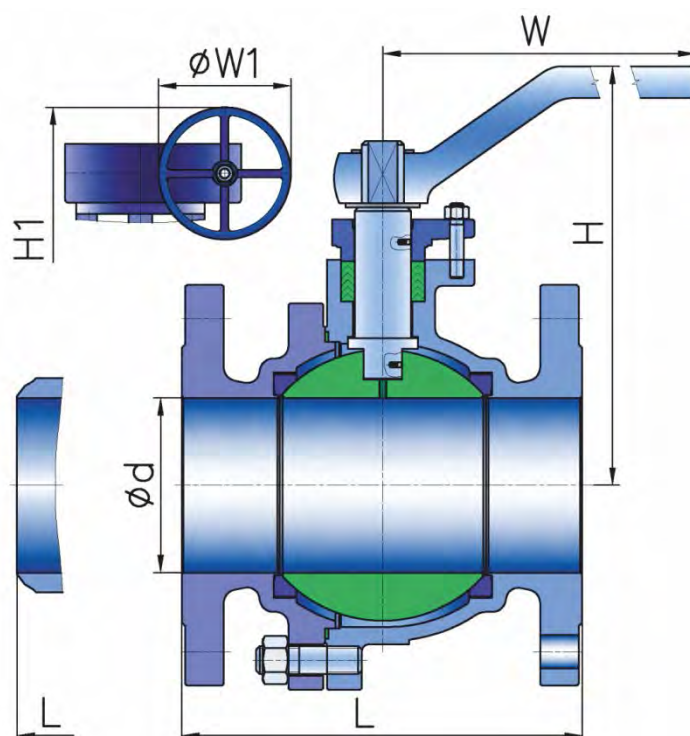

DN	PN 10, 16										PN 25											
	L			d	H	H1	W	W1	EN ISO 5211	(KG)		L			d	H	H1	W	W1	EN ISO 5211	(KG)	
	1	2								H.W.	G.O.	1	2								H.W.	G.O.
	LK	LD																				
6	115	130	270	6	65	-	140	-	F03 / F04	2.5	-	115	130	270	6	65	-	140	-	F03 / F04	2.5	-
10	115	130	270	10	65	-	140	-	F03 / F04	2.5	-	115	130	270	10	65	-	140	-	F03 / F04	2.5	-
15	115	130	270	15	85	-	140	-	F03 / F04	3	-	115	130	270	15	85	-	140	-	F03 / F04	3	-
20	120	150	270	20	90	-	140	-	F03 / F04	4	-	120	150	270	20	90	-	140	-	F03 / F04	4	-
25	125	160	270	25	99	-	150	-	F04 / F05	5	-	125	160	270	25	99	-	150	-	F03 / F04	5	-
32	130	180	270	32	105	-	180	-	F04 / F05	7	-	130	180	270	32	105	-	180	-	F04 / F05	7	-
40	140	200	270	40	126	-	200	-	F05 / F07	8	-	140	200	270	40	126	-	200	-	F05 / F07	9	-
50	150	230	300	50	40	-	250	-	F05 / F07	12	-	150	230	300	50	140	-	250	-	F05 / F07	12	-
65	170	290	360	65	165	-	300	-	F05 / F07	17	-	170	290	360	65	165	-	300	-	F05 / F07	19	-
80	180	310	390	80	178	-	350	-	F07 / F10	23	-	180	310	390	80	178	-	350	-	F07 / F10	23	-
100	190	350	450	100	230	380	500	305	F10 / F12	35	53	190	350	450	100	230	380	500	305	F10 / F12	45	53
125	325	400	525	125	280	405	800	305	F10 / F12	52	79	325	400	525	125	280	405	800	305	F12 / F14	67	79
150	350	480	600	150	310	460	800	305	F12 / F14	76	102	350	450	600	150	310	460	800	305	F14 / F16	95	102
200	400	600	600	200	350	550	1000	305	F14 / F16	134	185	400	550	600	200	350	550	1000	305	F16 / F25	170	185
250	450	730	730	250	-	550	-	305	F16 / F25	-	282	450	650	730	250	-	550	-	305	F25	-	295
300	500	850	850	300	-	690	-	400	F16 / F25	-	455	500	750	850	300	-	690	-	400	F25 / F35	-	475
350	550	980	980	350	-	750	-	400	F16 / F25	-	510	550	980	980	350	-	800	-	400	F25 / F35	-	750
400	762	1100	1100	400	-	895	-	400	F25 / F35	-	750	762	1100	1100	400	-	950	-	500	F25 / F35	-	920
500	914	1250	1250	500	-	980	-	500	F25 / F35	-	1190	914	1250	1250	500	-	1200	-	500	F25 / F35	-	1240

BALL VALVES

TYPE K81

DIMENSIONS

DN	PN 40										PN 63											
	L			d	H	H1	W	W1	EN ISO 5211	(KG)		L			d	H	H1	W	W1	EN ISO 5211	(KG)	
	1		2							H.W.	G.O.	1		2							H.W.	G.O.
	LK	LD		LK	LD																	
6	115	130	270	6	65	-	140	-	F03 / F04	2.5	-	115	130	270	6	68	-	140	-	F03 / F04	2.5	-
10	115	130	270	10	65	-	140	-	F03 / F04	2.5	-	115	130	270	10	68	-	140	-	F03 / F04	2.5	-
15	115	130	270	15	85	-	140	-	F03 / F04	3	-	115	130	270	15	79	-	140	-	F03 / F04	5	-
20	120	150	270	20	90	-	140	-	F04 / F05	4	-	-	150	270	20	83	-	140	-	F04 / F05	7	-
25	125	160	270	25	99	-	150	-	F04 / F05	5	-	125	160	270	25	114	-	200	-	F04 / F05	9	-
32	130	180	270	32	105	-	180	-	F04 / F05	8	-	130	180	270	32	120	-	200	-	F04 / F05	13	-
40	140	200	270	40	126	-	200	-	F05 / F07	11	-	140	200	270	40	125	-	250	-	F05 / F07	17	-
50	150	230	300	50	142	-	250	-	F07 / F10	15	-	150	230	300	50	156	-	300	-	F07 / F10	25	-
65	170	290	360	65	165	-	300	-	F10 / F12	20	-	170	290	360	65	172	-	350	-	F10 / F12	42	-
80	180	310	390	80	178	330	350	305	F12 / F14	29	47	180	310	390	80	220	390	500	305	F12 / F14	56	76
100	190	350	450	100	230	380	500	305	F14 / F16	48	68	190	350	450	100	250	440	650	305	F14 / F16	85	123
125	325	400	525	125	280	420	800	305	F16 / F25	68	88	-	-	-	-	-	-	-	-	-	-	-
150	350	450	600	150	310	480	800	305	F16 / F25	98	136	-	-	-	-	-	-	-	-	-	-	-
200	400	550	600	200	350	560	1000	400	F25 / F35	178	223	-	-	-	-	-	-	-	-	-	-	-
250	450	650	730	250	-	655	-	400	F25 / F35	-	395	-	-	-	-	-	-	-	-	-	-	-
300	500	750	850	300	-	660	-	400	F25 / F35	-	598	-	-	-	-	-	-	-	-	-	-	-
350	550	850	850	350	-	780	-	500	F25 / F35	-	820	-	-	-	-	-	-	-	-	-	-	-
400	762	950	950	400	-	920	-	500	F25 / F35	-	980	-	-	-	-	-	-	-	-	-	-	-
500	914	1150	1150	500	-	1130	-	500	F25 / F35	-	1340	-	-	-	-	-	-	-	-	-	-	-

DN	PN 100										
	L			d	H	H1	W	W1	EN ISO 5211	(KG)	
	1		2							H.W.	G.O.
	LK	LD									
6	115	130	270	6	65	-	140	-	F03 / F04	3	-
10	115	130	270	10	65	-	140	-	F03 / F04	3	-
15	115	130	270	15	79	-	140	-	F03 / F04	5	-
20	-	150	270	20	83	-	140	-	F04 / F05	7	-
25	125	160	270	25	114	-	200	-	F04 / F05	9	-
32	130	180	270	32	120	-	200	-	F04 / F05	13	-
40	140	200	270	38	125	-	250	-	F05 / F07	17	-
50	150	230	300	50	156	-	300	-	F07 / F10	25	-
65	170	290	360	65	172	-	350	-	F10 / F12	42	-
80	180	310	390	77	220	390	500	305	F12 / F14	56	76
100	190	350	450	100	250	440	650	305	F14 / F16	85	123

Face to face (FLG) is the same for all types of flange faces (B1,C,D,E,F)

WAFFER EXECUTION

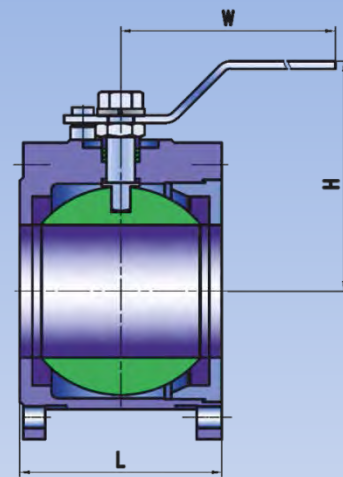

DN	L	H	W	(KG)
6	40	55	125	1,5
10	40	55	125	1,5
15	40	63	125	1,5
20	44	68	125	2,1
25	53	81	160	2,7
32	58	87	160	3,4
40	62	98	200	4
50	72	105	200	5,4
65	94	121	250	9,2
80	118	153	285	13,7
100	140	164	338	19,3

BALL VALVES

TYPE K81

TYPE DESIGNATION

K81 ABC DEF M PN/S

A FACE-TO- FACE DIMENSION

- 1 Short
- 2 Long

BODY DESIGN

- 2 Two pieces
- 3 Three pieces

F CONTROL

- 1 By hand lever
- 2 Hand wheel with gearbox
- 3 Electric actuator
- 4 Electric actuator with gearbox
- 5 Pneumatic actuator
- 6 Other actuator
- 9 Without control

S SPECIAL EXECUTION

- AS Antistatic design
- LT Low temperature design

D FLOW DIRECTION

- 1 Straight, full bore
- 2 Straight, reduced bore

M BODY MATERIAL

- 0 Stainless steel
- 2 Cast alloy steel
- 3 Forged alloy steel
- 4 Forged carbon steel
- 5 Cast carbon steel

C CONTROL STEM SEALING METHOD

- 1 2 x O- ring
- 2 O – ring + graphite (fire safe)
- 3 Graphite packing
- 4 PTFE packing
- 5 PTFE V-type ring packing

E CONNECTION INTO PIPE

- 0 Wafer
- 1 Flanged
- 2 Welded ends
- 4 Outside thread G
- 5 Outside thread NPT
- 6 Inside thread M
- 7 Inside thread G
- 8 Combined

B SEATS EXECUTION

- 1 PTFE
- 2 Metal
- 3 Metal+ fire safe
- 4 Graphite
- 5 PEEK

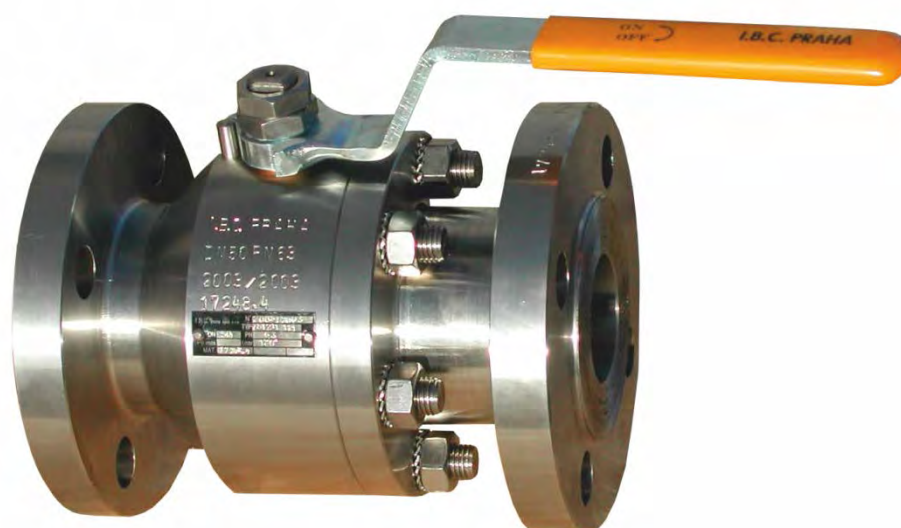



Range DN: 25 ~ 1000



PED 97/23/EC
PED 2014/68/EU



TR TS 10/11,
12/11, 32/11



Range PN: 16 ~ 160



**CERTIFICATE
API 607, 6FA**

Operating temperature: -196 °C ~ 550 °C

Connection into piping: Flanged, welded ends, threaded ends, combined execution



DESCRIPTION

K82 (floating seats and trunnion mounted ball) valves are controlled shut-off valves. They are designed to stop or allow the flow of the medium by external operation, either manually or via the installed drive. The ball valves allow the medium to flow in both directions. Their construction is designed to prevent the build-up of sediment in the flow channel which would otherwise hinder the valve operation. These ball valves are designed and manufactured to ensure maximum service life and reliability.

MATERIAL SPECIFICATION

K82 ball valves are made from carbon, alloy and stainless steels. The material type can be adjusted according to the customer's request to optimally suit the operating conditions..

APPLICATION

K82 ball valves are suitable for various liquids, gases and steam.

BASIC STANDARDS FOR DESIGN

Basic design

EN 1983

Pressure-temperature rating

EN 12 516 - 1

Testing

EN 12 266 - 1, 2

Face-to-face dimensions

EN 558, EN 12 982

Dimensions of the welded ends

EN 12 627

Top Flange dimensions

EN ISO 5211

Flange dimensions

EN 1092 - 1

Special

NACE MR-0175

BALL VALVES

TYPE K82

STRUCTURAL DESIGN

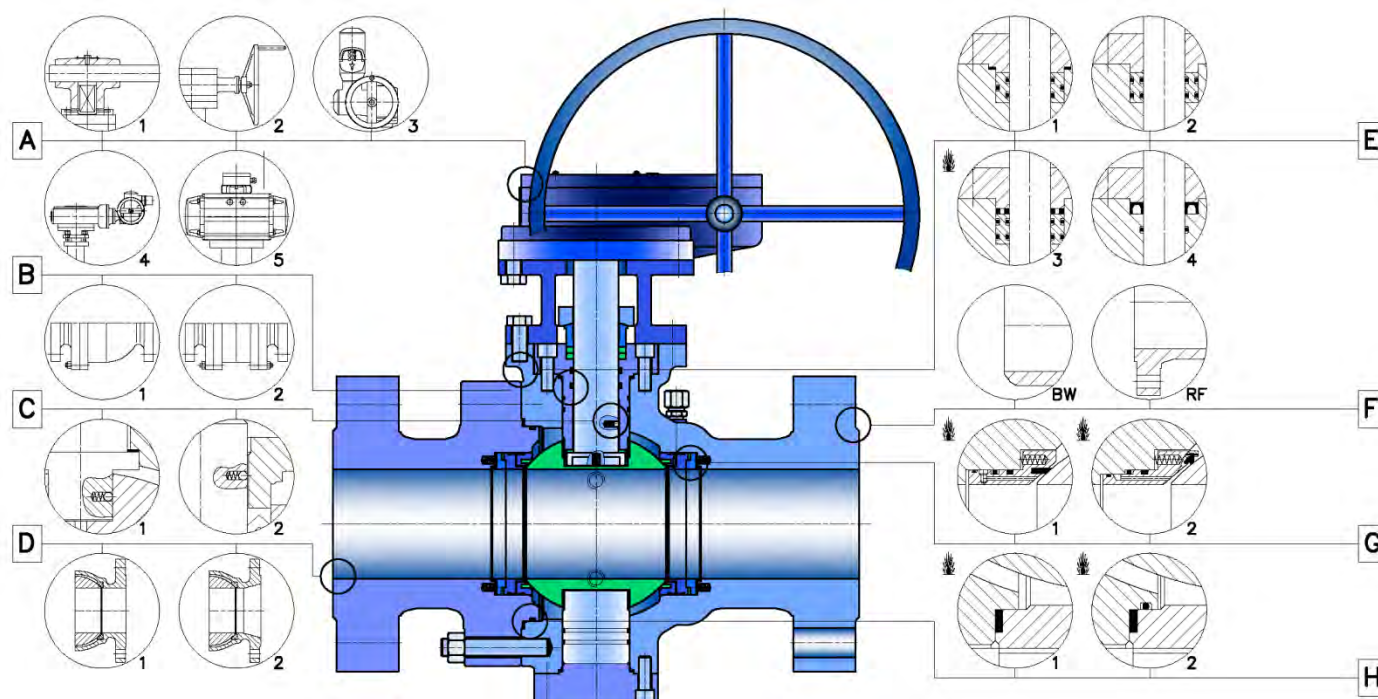

A - Control

- by hand lever
- gear box+hand wheel
- electric actuator
- electric actuator+gear box
- pneumatic actuator

B – Body design

- two pieces
- three pieces

C – Special execution

- antistatic design
- DPE
- LT

D - Flow direction

- straight, fullbore
- straight, reduced bore

E – Control stem sealing method

- dynamic – 2 x O-ring, static O-ring + Graphite
- dynamic – 2 x O-ring, static – 2 x O-ring
- dynamic - 2 x O-ring + Graphite (Fire safe design)
- static – 2 x O-ring + graphite (Fire safe design)
- O-ring + V-shaped PTFE ring packing

F – Connection to piping

- flanged
- threaded
- welded
- welded ends according to customer's requirements

G - Seats execution

- The seats are made with single or double piston effect, with the option to lubricate and execute in Fire safe design. Also the seats are supplied with "DBB" (double block and bleed) execution. The seats with single piston effect have the option to reduce the pressure in the intermediate space between the ball and body. The seats with double piston effect are pressed to the ball also by the fluid pressure in the intermediate space, which ensures hermetic closure at the inlet and the outlet side of the valve. To limit the pressure in the intermediate space of the body, an overflow device is mounted.

H – Bonnet sealing

- executed by a sealing ring or a combination of sealing ring and O-ring. To comply with Fire safe design, a graphite seal ring is used; moreover the body and bonnet are sealed by metal to metal

BALL VALVES

TYPE K82

MATERIAL SPECIFICATION

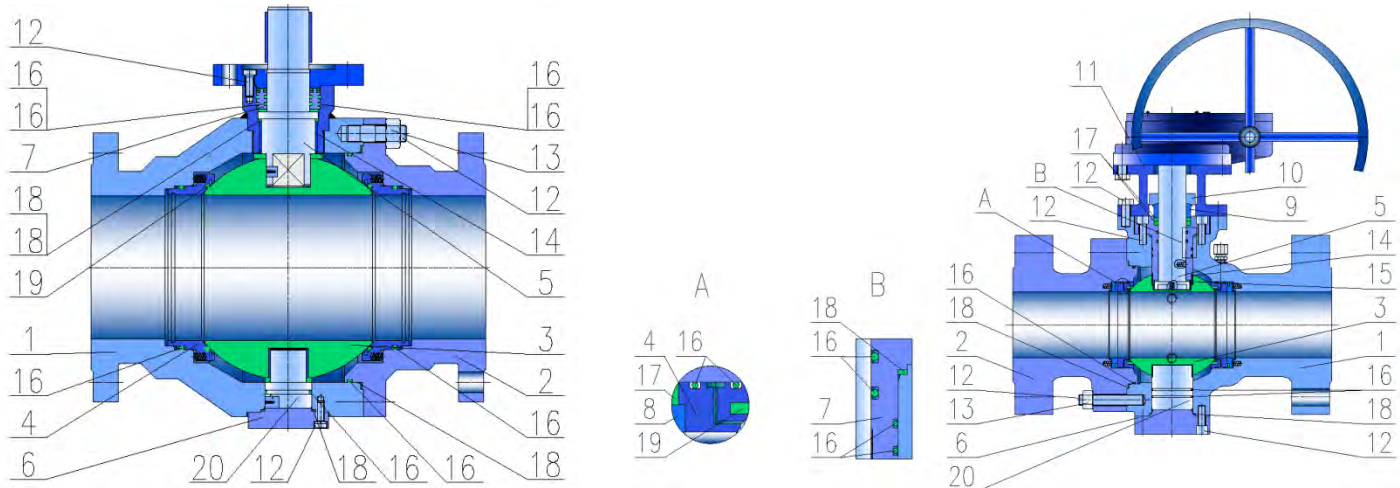

Pos	Designation	Foundry execution						Forged execution					
		WCB	LCB, LCC	CF3	CF3M	CF8	CF8M	LF2	A105	1.4541	F316L	F304	F316
1	Body	A216 WCB	A352 LCB, LCC	A351 F3	A351 CF3M	A351 CF8	A351 CF8M	A350 LF2	A105	1.4541	A182 F316L	A182 F304	A182 F316
2	Bonnet	A216 WCB	A352 LCB, LCC	A351 CF3	A351 CF3M	A351 CF8	A351 CF8M	A350 LF2	A105	1.4541	A182 F316L	A182 F304	A182 F316
3	Ball	A105 + ENP (Cr), A350 LF2 + ENP (Cr)	A352 LCB, LCC + ENP (Cr)	A351 CF3, A182 F304L	A351 CF3M, A182 F316L	A351 CF8, A182 F304	A351CF8 M, A182 F316	A350 LF2 + ENP (Cr)	A105 + ENP (Cr)	1.4541	A351 CF3M, A182 F316L	A351 CF8, A182 F304	A351 CF8M, A182 F316
4	Seat	A105 + ENP (Cr), A350 LF2 + ENP (Cr)	A182 F6a	A182 F304L	A182 F316L	A182 F304	A182 F316	A350 LF2 + ENP (Cr)	A105 + ENP (Cr)	1.4541	A182 F316L	A182 F304	A182 F316
5	Upper Stem	A182 F6a	A182 F6a	A182 F304L	A182 F316L	A182 F304	A182 F316	A182 F6a	A182 F6a	1.4541	A182 F316L	A182 F304	A182 F316
6	Bottom Cover	A105, A350 LF2	A182 F6a	A182 F304L	A182 F316L	A182 F304	A182 F316	A350 LF2	A105	1.4541	A182 F316L	A182 F304	A182 F316
7	Top Cover	A105, A350 LF2	A182 F6a	A182 F304L	A182 F316L	A182 F304	A182 F316	A350 LF2	A105	1.4541	A182 F316L	A182 F304	A182 F316
8	Thrust Ring of The Seat	A105 + ENP (Cr), A350 LF2 + ENP (Cr)	A182 F6a	A182 F304L	A182 F316L	A182 F304	A182 F316	A350 LF2 + ENP (Cr)	A105 + ENP (Cr)	1.4541	A182 F316L	A182 F304	A182 F316
9	Thrust Ring	A182 F6a	A182 F6a	A182 F304L	A182 F316	A182 F304	A182 F316	A182 F6a	A182 F6a	1.4541	A182 F316L	A182 F304	A182 F316
10	Gland Flange	A216 WCB	A352 LCB, LCC	A351 CF3	A351 CF3M	A351 CF8	A351 CF8M	A350 LF2	A105	1.4541	A182 F316L	A182 F304	A182 F316
11	Yoke	A216 WCB	A352 LCB, LCC	A351 CF3	A351 CF3M	A351 CF8	A381 CF8M	-	-	-	-	-	-
12	Bolt	A193 B7	A320 L7	A193 B8	A193 B8M	A193 B8	A193 B8M	25CrMo4	A193 B7	A2 - 70	A193 B8M	A193 B8	A193 B8M
13	Nut	A194 2H	A194 4	A194 8	A194 8M	A194 8	A194 8M	A2 - 70	A194 2H	A2 - 70	A194 8M	A194 8	A194 BM
14	Bushing	stainless steel + PTFE, bronze											
15	Washer	stainless steel + PTFE, bronze											
16	O-Ring	NITRIL, VITON, NBR, HNBR, EPDM											
17	Sealing Ring	graphite											
18	Gasket	graphite, graphite + stainless steel											
19	Seat Ring	NYLON, DEVLON, PTFE, RPTFE, PEEK, NITRIL, VITON, NBR, HNBR, EPDM											
20	Bottom Stem	A182 F6a	A182 F6a	A182 F304L	A182 F316L	A182 F304	A182 F316	A182 F6a	A182 F6a	1.1.4541	A182 F316L	A182 F304	A182 F316

BALL VALVES

TYPE K82

DIMENSIONS

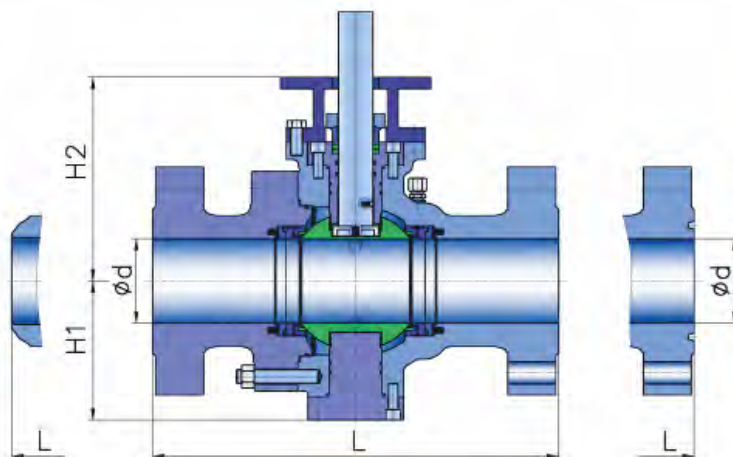

DN	PN 16						PN 25						PN 40											
	L		d	H1	H2	EN ISO 5211	(KG)		L		d	H1	H2	EN ISO 5211	(KG)		L		d	H1	H2	EN ISO 5211	(KG)	
	1	2					1	2	1	2					1	2	1	2					1	2
25	210	270	28,5	68	107	F07	16	20	210	270	28,5	68	107	F07	16	20	210	270	28,5	68	107	F07	17	21
50	230	300	54	107	119	F07	19	21	230	300	54	107	119	F07	19	21	230	300	54	107	119	F07	22	21
65	290	360	70	110	170	F10	34	33	290	360	70	110	170	F10	34	33	290	360	70	110	170	F10	40	33
80	310	390	82	118	215	F12	52	54	310	390	82	118	215	F12	52	54	310	390	82	118	215	F12	60	54
100	350	450	107	153	218	F12	69	66	350	450	107	153	218	F12	69	66	350	450	107	153	218	F12	82	66
125	400	525	132	170	229	F14	99	92	400	525	132	170	229	F14	99	92	400	525	131	170	229	F14	115	98
150	450	600	159	193	266	F16	154	132	450	600	159	193	266	F16	154	132	450	600	159	193	266	F16	175	145
200	550	600	207	240	312	F16	235	190	550	600	207	210	312	F16	235	190	550	600	207	210	312	F16	260	210
250	650	730	260	293	475	F25	300	245	650	730	259	270	475	F25	300	245	650	730	259	270	475	F16	350	285
300	750	850	310	340	510	F25	450	370	750	850	308	340	510	F25	450	370	750	850	308	340	510	F25	530	445
350	850	980	340	355	380	F25	685	580	850	980	340	355	380	F25	685	580	850	980	337	355	380	F25	770	660
400	950	1100	390	415	440	F25	930	810	950	1100	389	415	440	F25	930	810	950	1100	387	430	450	F25	1090	915
500	1150	1250	492	511	515	F30	1660	1400	1150	1250	488	490	515	F25	1660	1400	1150	1250	489	500	540	F30	1820	1540
600	1350	1143	594	600	605	F30	2810	2740	1350	1143	588	600	65	F30	2810	2740	1350	1143	591	620	620	F30	2900	2740
700	1550	1346	693	675	683	F35	4320	4050	1550	1346	686	675	683	F35	4320	4050	1550	1346	686	675	690	F35	4620	4050
800	1750	1524	793	760	775	F35	6090	5640	1750	1524	785	760	775	F35	6090	5640	1750	1524	781	785	815	F35	6430	5640
900	1950	1727	894	835	850	F35	8565	8040	1950	1727	882	835	850	F35	8565	8040	1950	1727	876	905	890	F40	8966	8040
1000	2150	1840	996	930	945	F35	10872	10260	2150	1840	981	930	945	F35	10872	10260	2150	1780	978	940	955	F40	10890	10260

DN	PN 63						PN 100						PN 160											
	L		d	H1	H2	EN ISO 5211	(KG)		L		d	H1	H2	EN ISO 5211	(KG)		L		d	H1	H2	EN ISO 5211	(KG)	
	1	2					1	2	1	2					1	2	1	2					1	2
25	210	270	28,5	68	101	F07	30	26	210	270	28,5	68	101	F07	30	26	210	270	28,5	68	101	F07	35	26
50	230	300	54	107	119	F07	35	28	230	300	52	107	119	F07	35	28	230	300	48	110	174	F12	63	40
65	290	360	69	110	170	F10	49	41	290	360	66	110	170	F10 / F12	54	43	290	360	60	120	196	F12	73	56
80	310	390	80	118	215	F12	66	58	310	390	78	118	215	F12	76	64	310	390	80	145	235	F16	83	69
100	350	450	100	153	218	F12	96	72	350	450	101	153	218	F12 / F14	107	75	350	450	99	175	270	F16	157	140
125	400	525	125	170	229	F14	133	115	400	525	124	170	229	F14 / F16	149	117	400	525	120	250	290	F25	240	203
150	450	600	150	193	266	F16	198	170	450	600	149	193	266	F16 / F25	225	195	450	600	143	330	300	F25	340	300
200	550	600	203	210	312	F16	305	265	550	600	194	210	312	F25	350	295	550	600	195	390	350	F30	570	520
250	650	730	253	270	475	F16	455	380	650	730	241	270	475	F25	545	470	650	730	235	445	425	F30	720	560
300	750	850	299	340	510	F25	615	535	750	850	288	340	510	F25	755	650	750	850	282	500	470	F35	990	770
350	850	980	337	380	400	F25	855	760	850	980	324	380	400	F30	980	860	-	-	-	-	-	-	-	-
400	950	1100	387	430	450	F25	1230	995	950	1100	387	430	450	F30	1340	1100	-	-	-	-	-	-	-	-
500	1150	1250	489	500	540	F30	1970	1690	1150	1250	489	500	540	F30	2110	1860	-	-	-	-	-	-	-	-
600	1350	1397	591	620	620	F35	3750	3320	1350	1397	591	615	620	F35	3850	3440	-	-	-	-	-	-	-	-
700	1550	1549	686	675	690	F40	5680	5130	-	-	-	-	-	-	-	-	-	-	-	-	-	-	-	-
800	1750	1651	781	785	815	F40	9197	8227	-	-	-	-	-	-	-	-	-	-	-	-	-	-	-	-

BALL VALVES

TYPE K82

TYPE DESIGNATION

K82 ABC DEF M PN/S

A FACE-TO- FACE DIMENSION

- 1 Short
- 2 Long

D FLOW DIRECTION

- 1 Straight, full bore
- 2 Straight, reduced bore

F CONTROL

- 1 By hand lever
- 2 Hand wheel with gearbox
- 3 Electric actuator
- 4 Electric actuator with gearbox
- 5 Pneumatic actuator
- 6 Other actuator
- 9 Without control

B SEATS EXECUTION

- 1 Polymer
- 2 Polymer + secondary sealing by paste
- 3 Polymer + fire safe
- 4 Polymer + fire safe + secondary sealing by paste
- 5 Metal + O - ring
- 6 Metal + O - ring + secondary sealing by paste
- 7 Metal + O - ring + fire safe

M BODY MATERIAL

- 0 Stainless steel
- 2 Cast alloy steel
- 3 Forged alloy steel
- 4 Forged carbon steel
- 5 Cast carbon steel

C CONTROL STEM SEALING METHOD

- 1 O - ring
- 2 O - ring+graphite
- 3 O - ring + graphite packing
- 4 V-shaped PTFE
- 5 Graphite packing

E CONNECTION INTO PIPE

- 1 Flanged ends
- 2 Welded ends
- 3 Threaded ends
- 8 Combined

S SPECIAL EXECUTION

- DPE** Seats with double piston effect
- AS** Antistatic design
- LT** Low temperature design

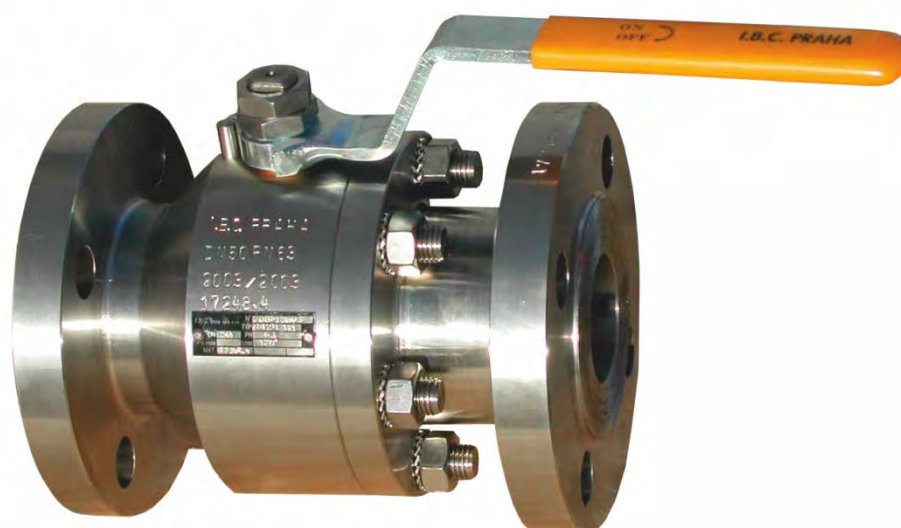



Range NPS: 1/4" ~ 20"



Range Class: 150 ~ 2500



PED 97/23/EC
PED 2014/68/EU



TR TS 10/11,
12/11, 32/11



EN 12 569
CERTIFICATE



CERTIFICATE
API 607, 6FA

Operating temperature: -196 °C ~ 550 °C

Connection into piping: Flanged, welded ends, threaded ends, combined execution



DESCRIPTION

K83 (floating ball) valves are controlled shut-off valves. They are designed to stop or allow the flow of the medium by external operation, either manually or via the installed drive. The ball valves allow the medium to flow in both directions. Their construction is designed to prevent the build-up of sediment in the flow channel which would otherwise hinder the valve operation. These ball valves are designed and manufactured to ensure maximum service life and reliability.

MATERIAL SPECIFICATION

K83 Ball valves are made from carbon, alloy and stainless steels. The material type can be adjusted according to the customer's request to optimally suit the operating conditions.

APPLICATION

K83 ball valves are suitable for various liquids, gases and steam.

BASIC STANDARDS FOR DESIGN

Basic design

API 608, API 6D

Pressure-temperature rating

ASME B16.34

Testing

API 598

Face-to-face dimensions

ANSI B16.10

Dimensions of the welded ends

ANSI B16.25

Top Flange dimensions

EN ISO 5211

Flange dimensions

ANSI B 16.5, ANSI B16.47A

Special

NACE MR-0175

BALL VALVES

TYPE K83

STRUCTURAL DESIGN

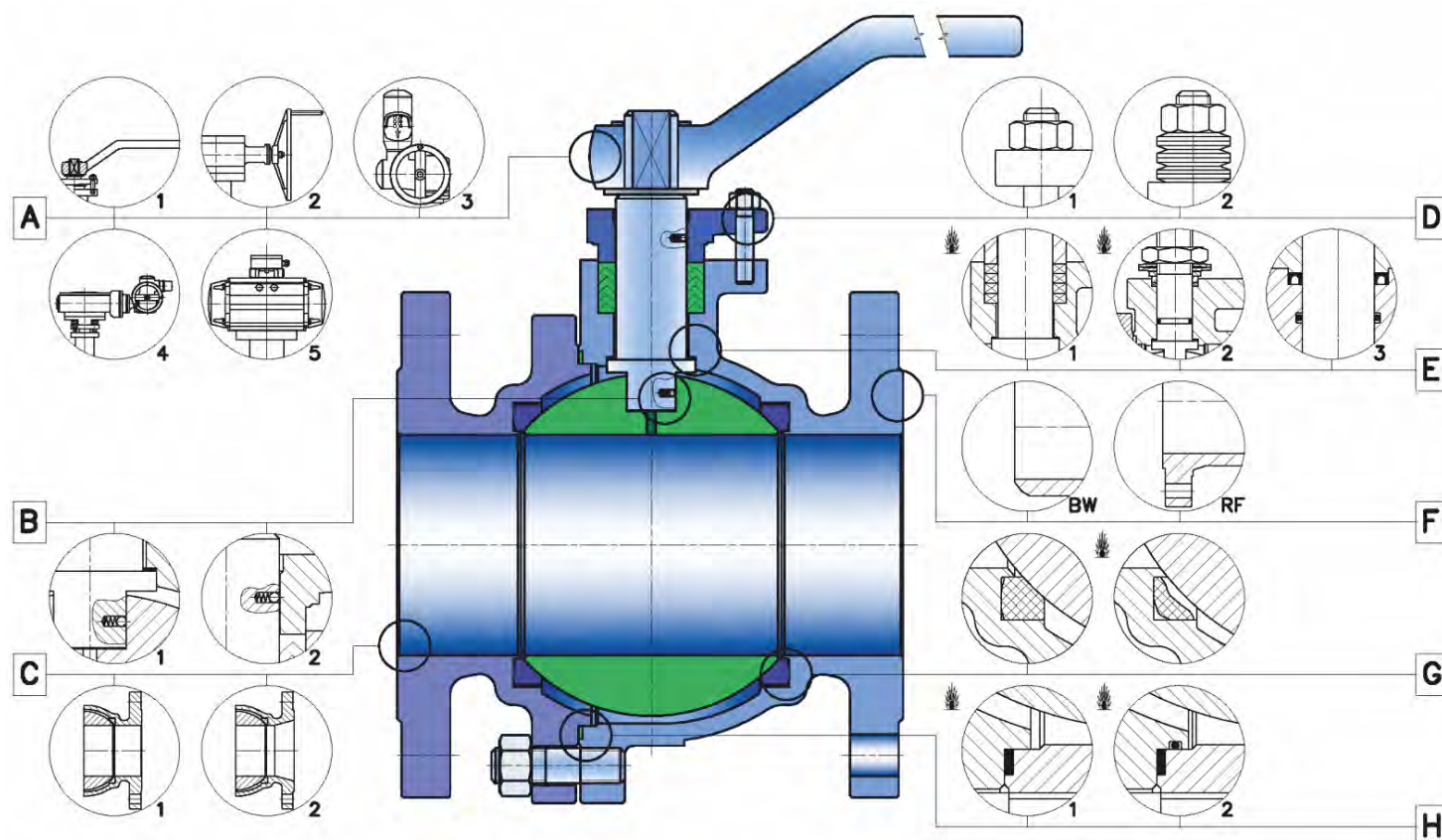

A - Control

- by hand lever
- gear box+hand wheel
- electric actuator
- electric actuator+gear box
- pneumatic actuator

B – Antistatic execution

- is solved by using springs and small balls. The ball is electrically connected with the control stem. The control stem is electrically connected with the body

C – Flow direction

- straight,full bore
- straight,reduced bore

D - Gland compression

- in case of valve operation with cyclic changes in pressure or at high pressures and temperatures, the gland compression by means of Belleville springs, which secure a constant pre-stress in packing, is preferred

E – Stem packing

- by graphite packing in compliance with Fire safe design
- by PTFE packing
- by O – ring and graphite ring, according to Fire safe design
- by O – ring and PTFE V-shaped ring packing

F – Connection into piping

- flanged
- welded
- socket welding
- threaded
- welded-ends according to customer's requirements

G- Execution of the seats

- execution of the seats meets the requirements of Fire safe design, i.e. in case of burnout seat ring, the tightness of the closure is secured by sealing of the ball against metal seat – there is metal to metal connection.

H – Bonnet sealing

- executed by sealing ring or a combination of sealing and O-ring. To comply with Fire safe design is used graphite seal ring, moreover body and cover are sealed by metal to metal

BALL VALVES

TYPE K83

MATERIAL SPECIFICATION

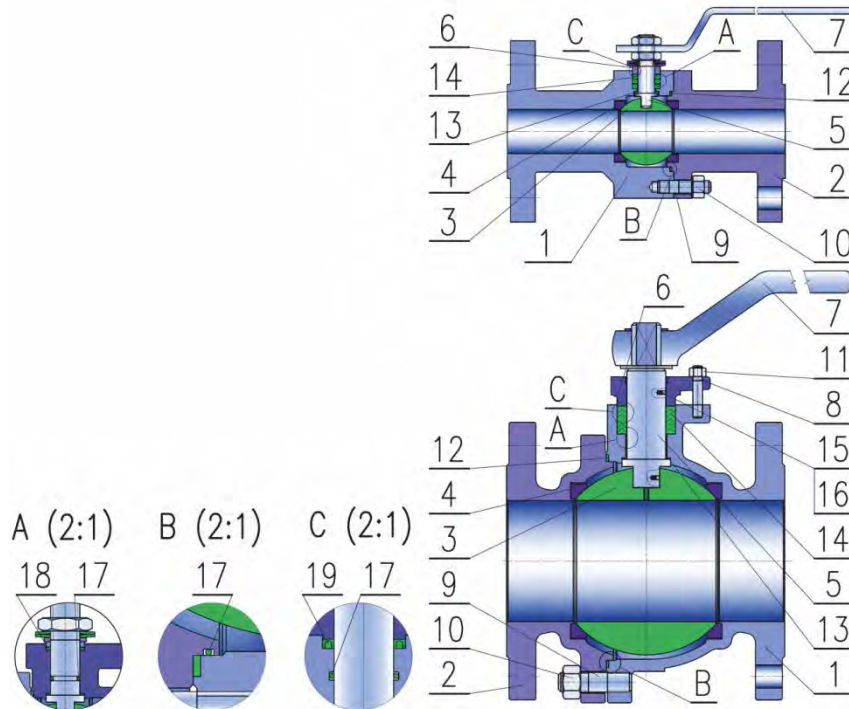

Pos.	Designation	FOUNDRY EXECUTION						FORGED EXECUTION					
		WCB	LCB/LCC	CF3	CF3M	CF8	CF8M	A350 LF2	A105	1.4551	F316L	F304	F316
1	Body	A216 WCB	A352 LCB, LCC	A351 CF3	A351 CF3M	A351 CF8	A351 CF8M	A350 LF2	A105	1.4541	A182 F316L	A182 F304	A182 F316
2	Bonnet	A216 WCB	A352 LCB, LCC	A351 CF3	A351CF3M	A351 CF8	A351 CF8M	A350 LF2	A105	1.4541	A182 F316L	A182 F304	A182 F316
3	Ball	A105 + ENP (Cr), A350 LF2 + ENP (Cr), A182 F304, A182 F316	A352 LCB, LCC + ENP (Cr) A182 F304, A182 F316	A351 CF3, A182 F304L	A351 CF3M, A182 F316L	A351 CF8, A182 F304	A351 CF8M, A182 F316	A350 LF2 + ENP (Cr)	A105 + ENP (Cr)	1.4541	A351 CF3M, A182 F316L	A351 CF8, A182 F304	A351 CF8M, A182 F316
4	Seat	PTFE, PTFE+ glass, PTFE + graphite, PTFE + stainless steel, PEEK, A182 F304, A182 F304L, A182 F316, A182 F316L											
5	Pin	A182 F6a	A182 F6a	A182 F304L	A182 F316L	A182 F304	A182 F316	A182 F6a	A182 F6a	1.4541	A182 F316L	A182 F304	A182 F316
6	Gland Flange	A216 WCB	A352 LCB, LCC	A351 CF3	A351 CF3M	A351 CF8	A351 CF8M	A350 LF2	A105	1.4541	A182 F304L	A182 F304	A182 F316
7	Lever	carbon steel											
8	Bolt	A193 B7	A320 L7	A193 B8	A193 B8M	A193 B8	A193 B8M	25CrMo ₄	A193 B7	A2-70	A193 B8M	A193 B8	A193 B8M
9	Bolt	A193 B7	A320 L7	A193 B8	A193 B8M	A193 B8	A193 B8M	25CrMo ₄	A193 B7	A2-70	A193 B8M	A193 B8	A193 B8M
10	Nut	A194 2H	A194 4	A194 8	A194 8M	A194 8	A194 8M	A2-70	A194 2H	A2-70	A194 8M	A194 8	A194 8M
11	Nut	A194 2H	A194 4	A194 8	A194 8M	A194 8	A194 8M	A2-70	A194 2H	A2-70	A194 8M	A194 8	A194 8M
12	Gasket	graphite, PTFE, PTFE+ glass, PTFE + graphite, PTFE + stainless steel											
13	Washer	PTFE, PTFE+ glass, PTFE + graphite, PTFE + stainless steel, bronze											
14	Gland Packing	graphite, PTFE, PTFE+ glass, PTFE + graphite, PTFE + stainless steel											
15	Spring	Stainless steel											
16	Small Ball	Stainless steel											
17	O - Ring	NBR, HNBR, EPDM, VITON, VITON GLT, SI											
18	Seal	graphite											
19	Sealing Ring	PTFE, with PTFE filler + spring from stainless steel											

BALL VALVES

TYPE K83

DIMENSIONS

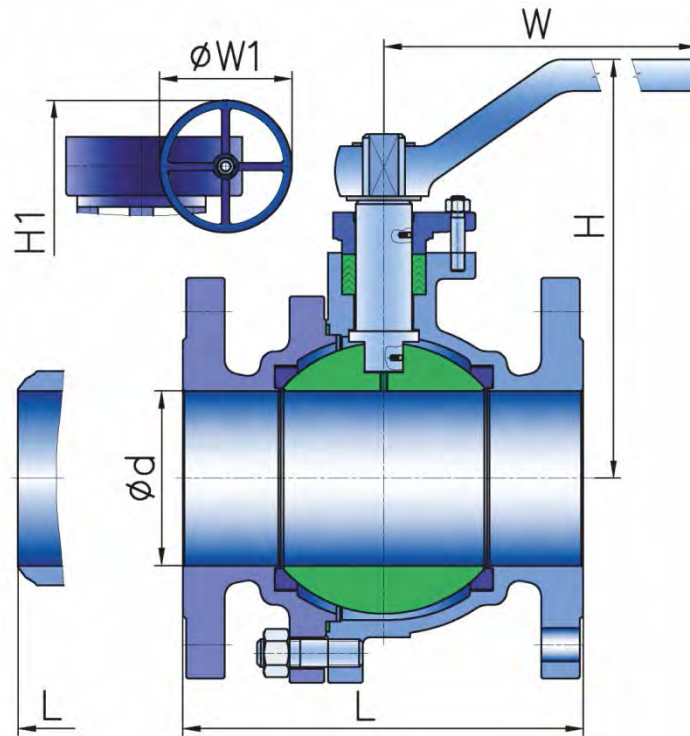

NPS	DN	CLASS 150											CLASS 300										
		L			d	H	H1	W	W1	EN ISO 5211	(KG)		L			d	H	H1	W	W1	EN ISO 5211	(KG)	
		1/RF	1/RTJ	2							H.W.	G.O.	1/RF	1/RTJ	2							H.W.	G.O.
1/4	6	108	-	140	6	62	-	140	-	F03	3	-	140	-	140	6	62	-	140	-	F03	3	-
3/8	10	108	-	140	10	70	-	140	-	F03	3	-	140	-	140	10	70	-	140	-	F03	3	-
1/2	15	108	119	140	14	85	-	140	-	F03	3	-	140	151	140	14	85	-	140	-	F03	3	-
3/4	20	117	130	152	19	90	-	140	-	F03	4	-	152	165	152	19	90	-	140	-	F03	5	-
1	25	127	140	165	25	99	-	150	-	F03	5	-	165	178	165	25	99	-	150	-	F03	6	-
1 1/4	32	140	153	178	32	105	-	180	-	F04	7	-	178	191	178	32	105	-	180	-	F04	8	-
1 1/2	40	165	178	190	38	126	-	200	-	F04	8	-	190	203	190	38	126	-	200	-	F04	11	-
2	50	178	191	216	51	140	-	250	-	F05	12	-	216	232	216	51	140	-	250	-	F05	16	-
2 1/2	65	190	203	241	64	165	-	300	-	F05 / F07	18	-	241	257	241	64	165	-	300	-	F05 / F07	24	-
3	80	203	216	283	76	178	-	350	-	F07 / F10	24	-	283	299	283	76	178	330	350	305	F07 / F10	34	52
4	100	229	242	305	102	230	380	500	305	F10 / F12	38	53	305	321	305	102	230	380	500	305	F10 / F12	56	76
5	125	356	369	381	127	280	405	800	305	F12 / F14	60	79	381	397	381	127	280	420	800	305	F12 / F14	86	124
6	150	394	407	457	152	310	460	800	305	F12 / F14	82	102	403	419	457	152	310	480	800	305	F14 / F16	125	163
8	200	457	470	521	203	350	550	1000	305	F14 / F16	145	185	502	518	521	203	350	560	1000	305	F16 / F25	222	267
10	250	533	546	559	254	-	706	-	400	F25	-	280	568	584	559	254	-	720	-	400	F25	-	365
12	300	610	622	635	303	-	798	-	400	F30	-	460	648	664	635	303	-	800	-	400	F30	-	530
14	350	686	699	762	337	-	864	-	400	F30	-	510	762	778	762	337	-	864	-	400	F30	-	740
16	400	762	775	838	387	-	913	-	400	F40	-	750	838	854	838	387	-	913	-	400	F40	-	1030
18	150	864	876	914	438	-	967	-	400	F48	-	895	914	930	914	438	-	967	-	400	F48	-	1320
20	500	914	927	991	489	-	1010	-	600	F60	-	1190	991	1010	991	489	-	1020	-	600	F60	-	1540

BALL VALVES

TYPE K83

DIMENSIONS

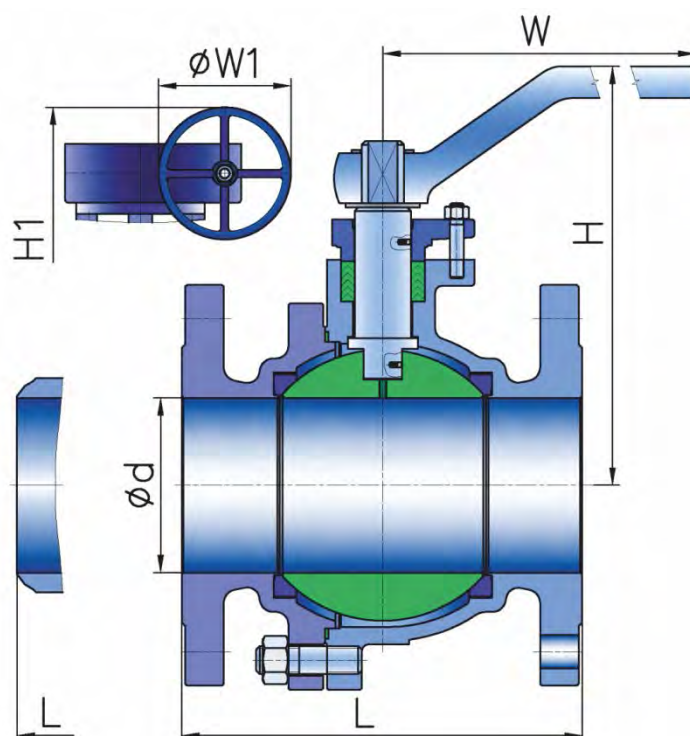

		CLASS 600										CLASS 900													
		L				d	H	H1	W	W1	EN ISO 5211	(KG)		L				d	H	H1	W	W1	EN ISO 5211	t(KG)	
NPS	DN	1/RF	1/RTJ	2	H.W.							G.O.	1/RF	1/RTJ	2	H.W.	G.O.								
1/4	6	165	-	165	6	62	-	140	-	F04	3	-	216	-	216	6	78	-	150	-	F07	4	-		
3/1	10	165	-	165	10	70	-	140	-	F04	4	-	216	-	216	10	78	-	150	-	F07	5	-		
1/2	15	165	163.5	165	14	79	-	140	-	F04	5	-	216	214	216	14	98	-	150	-	F07	9	-		
3/4	20	190	190	190	19	83	-	140	-	F04	7	-	229	229	229	20	105	-	150	-	F07	13	-		
1	25	216	216	216	25	114	-	200	-	F05	9	-	254	254	254	25	110	-	200	-	F10 / F12	16	-		
1 1/4	32	229	229	229	32	120	-	200	-	F05	13	-	279	279	279	32	120	-	250	-	F12	24	-		
1 1/2	40	241	241	241	38	125	-	250	-	F07	17	-	305	305	305	38	125	-	250	-	F12	31	-		
2	50	292	295	292	51	156	-	300	-	F07	25	-	368	374	368	50	160	-	350	-	F12 / F14	45	-		
2 1/2	65	330	333	330	64	172	-	350	-	F10 / F12	42	-	-	-	-	-	-	-	-	-	-	-	-		
3	80	356	359	356	76	220	370	500	305	F12	56	76	-	-	-	-	-	-	-	-	-	-	-		
4	100	432	435	432	102	250	400	650	305	F12 / F14	85	123	-	-	-	-	-	-	-	-	-	-	-		

		CLASS 1500											
		L				d	H	H1	W	W1	EN ISO 5211	(KG)	
NPS	DN	1/RF	1/RTJ	2	H.W.							G.O.	
1/4	6	216	-	216	10	98	-	182	-	F307	6	-	
3/8	10	216	-	216	10	98	-	182	-	F07	8	-	
1/2	15	216	214.3	216	14	98	-	182	-	F07	10	-	
3/4	20	229	229	229	20	105	-	200	-	F07	14	-	
1	25	254	254	254	25	110	-	250	-	F10 / F12	17	-	
1 1/4	32	279	279	279	32	120	-	300	-	F12	25	-	
1 1/2	40	305	305	305	38	130	-	350	-	F12	33	-	
2	50	368	374	368	50	160	-	500	-	F12 / F14	48	-	

		CLASS 2500						
NPS	DN	L	d	W	H	EN ISO 5211		
1/4"	6	264	6	165	120	F 07		
3/8"	10	264	10	165	120	F 07		
1/2"	15	264	15	165	120	F 07		
3/4"	20	273	20	185	145	F 07		
1"	25	308	25	200	165	F 10/F 12		
1 1/2"	40	384	38	230	190	F 12		
2"	50	451	49	315	255	F 12/F 14		

BALL VALVES

TYPE K83

TYPE DESIGNATION

K83 ABC DEF M Class/S
A FACE-TO- FACE DIMENSION

- 1 Short
- 2 Long

BODY DESIGN

- 2 Two pieces
- 3 Three pieces

F CONTROL

- 1 By hand lever
- 2 Hand wheel with gearbox
- 3 Electric actuator
- 4 Electric actuator with gearbox
- 5 Pneumatic actuator
- 6 Other actuator
- 9 Without control

S SPECIAL EXECUTION

- AS** Antistatic design
- LT** Low temperature design

D FLOW DIRECTION

- 1 Straight, full bore
- 2 Straight, reduced bore

M BODY MATERIAL

- 0 Stainless steel
- 2 Cast alloy steel
- 3 Forged alloy steel
- 4 Forged carbon steel
- 5 Cast carbon steel

C CONTROL STEM SEALING METHOD

- 1 2 x O- ring
- 2 O – ring + graphite (fire safe)
- 3 Graphite packing
- 4 PTFE packing
- 5 PTFE V-type ring packing

E CONNECTION INTO PIPE

- 0 Wafer
- 1 Flanged
- 2 Welded ends
- 4 Outside thread G
- 5 Outside thread NPT
- 6 Inside thread M
- 7 Inside thread G
- 8 Combined

B SEATS EXECUTION

- 1 PTFE
- 2 Metal
- 3 Metal+ fire safe
- 4 Graphite
- 5 PEEK

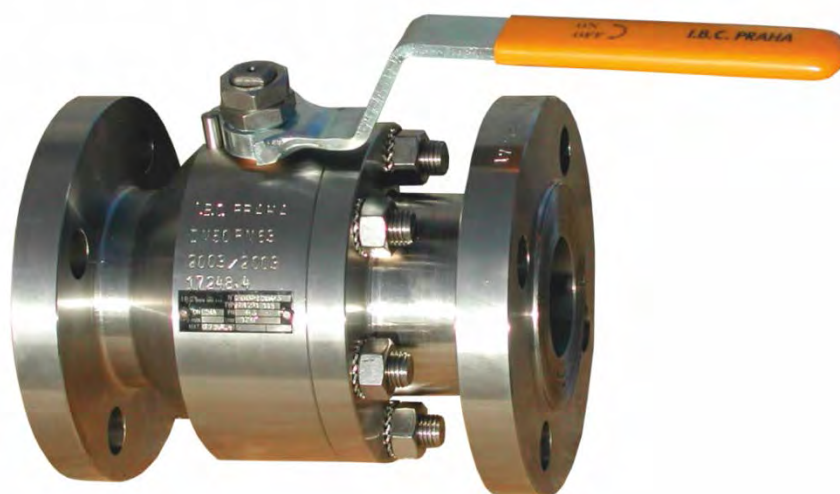



Range NPS: 1/2" ~ 56"



Range Class: 150 ~ 2500



PED 97/23/EC
PED 2014/68/EU



TR TS 10/11,
12/11, 32/11



EN 12 569
CERTIFICATE



CERTIFICATE
API 607, 6FA

Operating temperature: -196 °C ~ 550 °C

Connection into piping: Flanged, welded ends, threaded ends, combined execution



DESCRIPTION

K84 (floating seats and trunnion mounted ball) valves are controlled shut-off valves. They are designed to stop or allow the flow of the medium by external operation, either manually or via the installed drive. The ball valves allow the medium to flow in both directions. Their construction is designed to prevent the build-up of sediment in the flow channel which would otherwise hinder the valve operation. These ball valves are designed and manufactured to ensure maximum service life and reliability.

MATERIAL SPECIFICATION

K84 ball valves are made from carbon, alloy and stainless steels. The material type can be adjusted according to the customer's request to optimally suit the operating conditions.

APPLICATION

K84 ball valves are suitable for various liquids, gases and steam.

BASIC STANDARDS FOR DESIGN

Basic design

API 608, API 6D

Pressure-temperature rating

ASME B16.34

Testing

API 598

Face-to-face dimensions

ANSI B16.10

Dimensions of the welded ends

ANSI B16.25

Top Flange dimensions

EN ISO 5211

Flange dimensions

ANSI B 16.5, ANSI B16.47A

Special

NACE MR-0175

BALL VALVES

TYPE K84

STRUCTURAL DESIGN

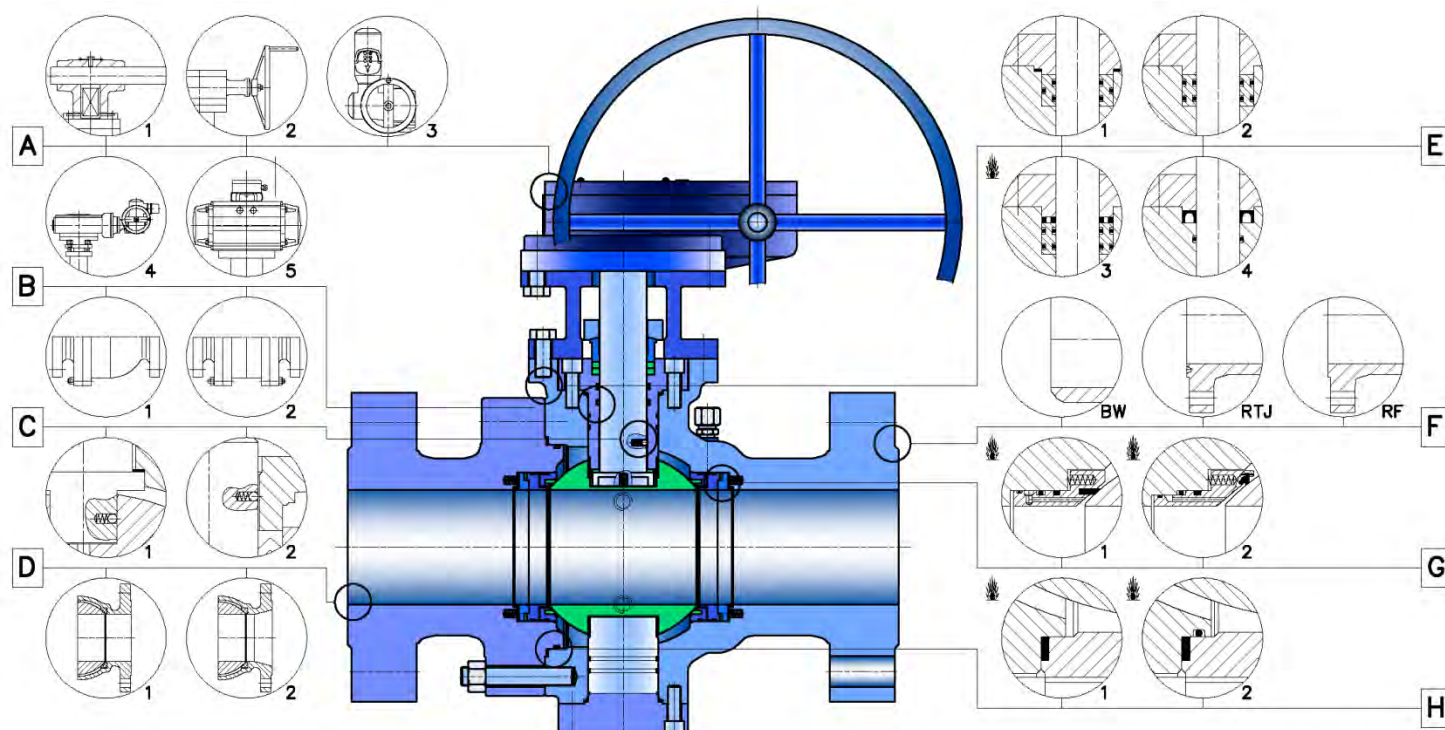

A - Control

- by hand lever
- gear box+hand wheel
- electric actuator
- electric actuator+gear box
- pneumatic actuator

B – Body design

- two pieces
- three pieces

C – Special execution

- antistatic design
- DPE
- LT

D - Flow direction

- straight, fullbore
- straight, reduced bore

E – Control stem sealing method

- dynamic – 2 x O-ring, static O-ring + Graphite
- dynamic – 2 x O-ring, static – 2 x O-ring
- dynamic - 2 x O-ring + Graphite (Fire safe design)
- static – 2 x O-ring + graphite (Fire safe design)
- O-ring + V-shaped PTFE ring packing

F – Connection to piping

- flanged
- threaded
- welded
- welded ends according to customer's requirements

G - Seats execution

- The seats are made with single or double piston effect, with the option to lubricate and execute in Fire safe design. Also the seats are supplied with "DBB" (double block and bleed) execution. The seats with single piston effect have the option to reduce the pressure in the intermediate space between the ball and body. The seats with double piston effect are pressed to the ball also by the fluid pressure in the intermediate space, which ensures hermetic closure at the inlet and the outlet side of the valve. To limit the pressure in the intermediate space of the body, an overflow device is mounted.

H – Bonnet sealing

- executed by a sealing ring or a combination of sealing ring and O-ring. To comply with Fire safe design, a graphite seal ring is used; moreover the body and bonnet are sealed by metal to metal

BALL VALVES

TYPE K84

MATERIAL SPECIFICATION

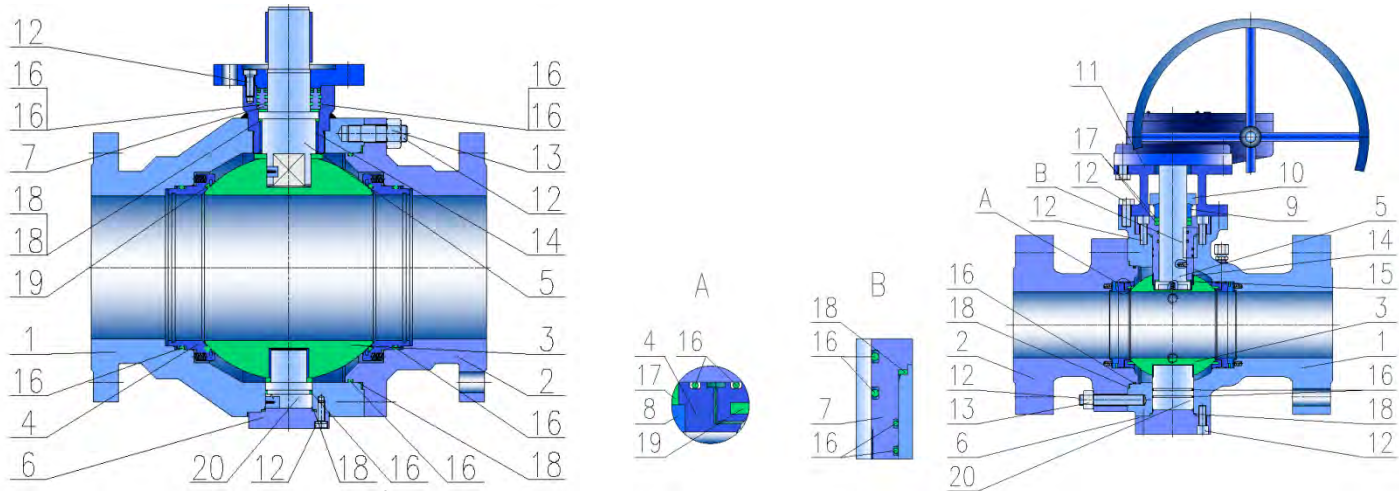

Pos	Designation	Foundry execution						Forged execution					
		WCB	LCB, LCC	CF3	CF3M	CF8	CF8M	LF2	A105	1.4541	F316L	F304	F316
1	Body	A216 WCB	A352 LCB, LCC	A351 F3	A351 CF3M	A351 CF8	A351 CF8M	A350 LF2	A105	1.4541	A182 F316L	A182 F304	A182 F316
2	Bonnet	A216 WCB	A352 LCB, LCC	A351 CF3	A351 CF3M	A351 CF8	A351 CF8M	A350 LF2	A105	1.4541	A182 F316L	A182 F304	A182 F316
3	Ball	A105 + ENP (Cr), A350 LF2 + ENP (Cr)	A352 LCB, LCC + ENP (Cr)	A351 CF3, A182 F304L	A351 CF3M, A182 F316L	A351 CF8, A182 F304	A351CF8 M, A182 F316	A350 LF2 + ENP (Cr)	A105 + ENP (Cr)	1.4541	A351 CF3M, A182 F316L	A351 CF8, A182 F304	A351 CF8M, A182 F316
4	Seat	A105 + ENP (Cr), A350 LF2 + ENP (Cr)	A182 F6a	A182 F304L	A182 F316L	A182 F304	A182 F316	A350 LF2 + ENP (Cr)	A105 + ENP (Cr)	1.4541	A182 F316L	A182 F304	A182 F316
5	Upper Stem	A182 F6a	A182 F6a	A182 F304L	A182 F316L	A182 F304	A182 F316	A182 F6a	A182 F6a	1.4541	A182 F316L	A182 F304	A182 F316
6	Bottom Cover	A105, A350 LF2	A182 F6a	A182 F304L	A182 F316L	A182 F304	A182 F316	A350 LF2	A105	1.4541	A182 F316L	A182 F304	A182 F316
7	Top Cover	A105, A350 LF2	A182 F6a	A182 F304L	A182 F316L	A182 F304	A182 F316	A350 LF2	A105	1.4541	A182 F316L	A182 F304	A182 F316
8	Thrust Ring of The Seat	A105 + ENP (Cr), A350 LF2 + ENP (Cr)	A182 F6a	A182 F304L	A182 F316L	A182 F304	A182 F316	A350 LF2 + ENP (Cr)	A105 + ENP (Cr)	1.4541	A182 F316L	A182 F304	A182 F316
9	Thrust Ring	A182 F6a	A182 F6a	A182 F304L	A182 F316	A182 F304	A182 F316	A182 F6a	A182 F6a	1.4541	A182 F316L	A182 F304	A182 F316
10	Gland Flange	A216 WCB	A352 LCB, LCC	A351 CF3	A351 CF3M	A351 CF8	A351 CF8M	A350 LF2	A105	1.4541	A182 F316L	A182 F304	A182 F316
11	Yoke	A216 WCB	A352 LCB, LCC	A351 CF3	A351 CF3M	A351 CF8	A381 CF8M	-	-	-	-	-	-
12	Bolt	A193 B7	A320 L7	A193 B8	A193 B8M	A193 B8	A193 B8M	25CrMo4	A193 B7	A2 - 70	A193 B8M	A193 B8	A193 B8M
13	Nut	A194 2H	A194 4	A194 8	A194 8M	A194 8	A194 8M	A2 - 70	A194 2H	A2 - 70	A194 8M	A194 8	A194 BM
14	Bushing	stainless steel + PTFE, bronze											
15	Washer	stainless steel + PTFE, bronze											
16	O-Ring	NITRIL, VITON, NBR, HNBR, EPDM											
17	Sealing Ring	graphite											
18	Gasket	graphite, graphite + stainless steel											
19	Seat Ring	NYLON, DEVLON, PTFE, RPTFE, PEEK, NITRIL, VITON, NBR, HNBR, EPDM											
20	Bottom Stem	A182 F6a	A182 F6a	A182 F304L	A182 F316L	A182 F304	A182 F316	A182 F6a	A182 F6a	1.1.4541	A182 F316L	A182 F304	A182 F316

BALL VALVES

TYPE K84

DIMENSIONS

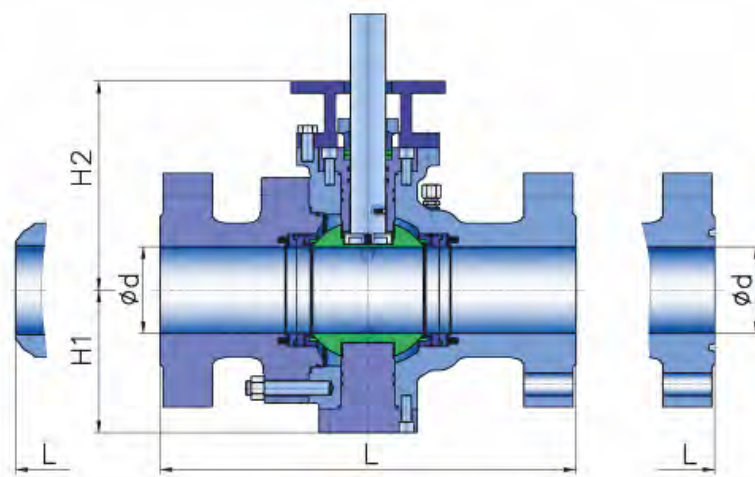

NPS	DN	CLASS 150								CLASS 300							
		L		d	H1	H2	EN ISO 5211	(KG)		L		d	H1	H2	EN ISO 5211	(kg)	
		1/RF	2					1/RF	2	1/RF	2					1/RF	2
1/2	15	108	140	13	45	55	F03	2,5	1,8	140	140	15	45	55	F03	2,5	1,8
1	25	127	165	25	65	70	F05	5,8	3,7	165	165	25	65	70	F05	5,5	4,2
1 1/2	40	165	190	38	107	119	F05	9	7,5	190	190	38	107	119	F07	13	9
2	50	178	216	49	110	170	F07	15	12	216	216	49	110	170	F10	20	15
2 1/2	65	191	241	62	118	215	F07	25	19	241	241	62	118	215	F12	31	25
3	80	203	283	74	153	218	F10	31	28	283	283	74	153	218	F12	42	31
4	100	229	305	100	170	229	F12	47	39	305	305	100	170	229	F14	66	52
6	150	394	457	152	231	245	F12	170	145	403	457	152	231	245	F16	178	145
8	200	457	521	203	277	288	F14	270	245	502	521	203	277	288	F25	293	245
10	250	533	559	254	310	331	F16	354	320	568	559	254	310	331	F30	392	320
12	300	610	635	305	344	368	F25	610	560	648	635	305	344	368	F30	660	560
14	350	686	762	337	370	393	F30	925	860	762	762	337	370	393	F30	990	860
16	400	762	838	387	415	437	F30	1206	1036	838	838	387	415	437	F35	1286	1036
18	450	864	914	438	453	470	F35	1540	1320	914	914	438	453	470	F35	1640	1320
20	500	914	991	489	491	515	F35	1832	1758	991	991	489	491	515	F35	1928	1758
24	600	1067	1143	591	598	605	F40	2970	2860	1143	1143	591	598	605	F40	3060	2860
26	650	1143	1245	633	628	622	F40	4140	3450	1245	1245	633	750	622	F40	3450	4140
28	700	1245	1346	686	675	683	F35	4533	4250	1346	1346	686	675	683	F40	4815	4250
30	750	1295	1397	737	712	721	F30	5307	5000	1397	1397	737	718	721	F40	5595	5000
32	800	1372	1524	781	763	775	F48	6090	5640	1524	1524	781	763	775	F48	6430	5640
36	900	1524	1727	876	834	849	F48	8565	8040	1727	1727	876	834	849	F48	8966	8040
40	1000	1900	1850	978	928	943	F48	10872	10260	1900	1850	978	928	943	F48	10890	10260
44	1100	1950	1900	1075	950	1280	F48	13825	12630	1950	1900	1075	950	1280	F48	15920	14340
48	1200	2180	2100	1166	1000	1350	F48	16915	15230	2180	2100	1166	1000	1350	F48	17916	16757
56	1400	2300	2250	1360	1150	1520	F48	20833	18750	2300	2250	1360	1150	1520	F48	23451	21644

BALL VALVES

TYPE K84

DIMENSIONS

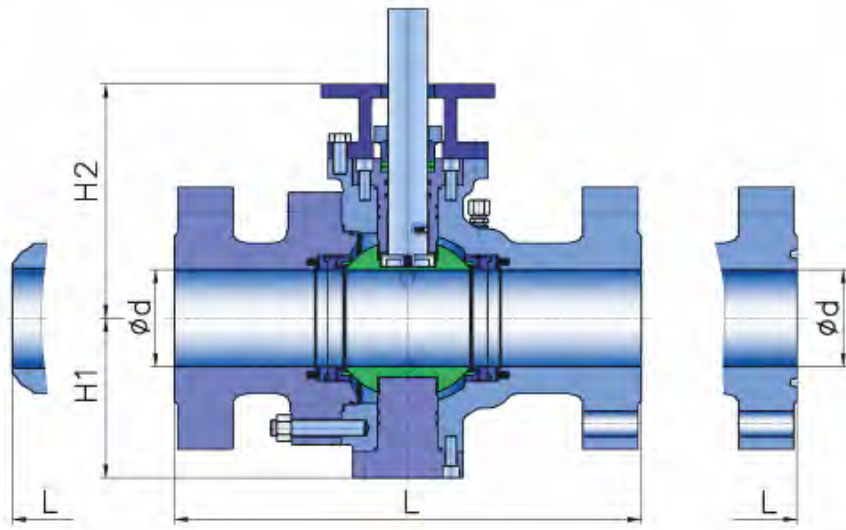

		CLASS 600									CLASS 900								
		L			d	H1	H2	EN ISO 5211	(KG)		L			d	H1	H2	EN ISO 5211	(KG)	
NPS	DN	1/RF	1/RTJ	2					RF	BW	1/RF	1/RTJ	2					RF	BW
1/2	15	165	165	165	15	45	55	F05	3,3	2,6	-	-	-	-	-	-	-	-	
1	25	216	216	216	25	65	70	F07	7,2	4,8	-	-	-	-	-	-	-	-	
1 1/2	32	241	241	241	38	107	119	F07	14	9	-	-	-	-	-	-	-	-	
2	50	292	292	295	51	110	170	F10	25	19	368	368	371	49	98	118	F12	59	35
2 1/2	65	330	330	333	64	118	215	F12	45	39	419	419	422	62	120	153	F14	67	50
3	80	356	356	359	76	153	218	F14	53	48	381	381	384	74	140	170	F14	85	71
4	100	432	432	435	102	170	229	F16	84	70	457	457	460	100	162	193	F14	177	160
6	150	559	559	562	152	237	249	F25	208	152	610	610	613	152	213	255	F16	286	230
8	200	660	660	664	203	277	297	F25	378	295	737	737	740	203	270	295	F25	440	345
10	250	787	787	791	254	314	337	F30	560	420	838	838	841	254	322	357	F25	720	560
12	300	838	838	841	305	355	378	F30	824	663	965	965	968	305	360	386	F30	990	770
14	350	889	889	892	334	381	400	F35	1080	923	1029	1029	1038	324	400	420	F60	1220	950
16	400	991	991	994	385	427	448	F35	1714	1434	1130	1130	1140	375	460	471	F30	1610	1150
18	450	1092	1092	1095	436	460	492	F40	2120	1830	1219	1219	1232	425	486	509	F30	2600	2140
20	500	1194	1194	1200	487	500	538	F40	2664	2250	1321	1321	1334	473	530	547	F35	3480	2860
24	600	1397	1397	1407	538	615	615	F40	4092	3550	-	-	-	-	-	-	-	-	-
28	700	1549	1549	1562	636	675	690	F48	5800	5420	-	-	-	-	-	-	-	-	-
30	750	1651	1651	1664	737	733	762	F48	7083	6450	-	-	-	-	-	-	-	-	-
32	800	1778	1778	1794	781	783	815	F48	9137	8330	-	-	-	-	-	-	-	-	-
36	900	2083	2083	2099	876	905	892	F48	11549	10690	-	-	-	-	-	-	-	-	-
40	1000	2180	2100	-	978	943	955	F60	14355	13210	-	-	-	-	-	-	-	-	-
44	1100	2200	2200	-	1075	982	1013	F60	16595	15281	-	-	-	-	-	-	-	-	-
48	1200	2400	2400	-	1166	1105	1135	F60	25443	23102	-	-	-	-	-	-	-	-	-
56	1400	2600	2600	-	1360	1254	1290	F60	31414	27830	-	-	-	-	-	-	-	-	-

BALL VALVES

TYPE K84

DIMENSIONS

		CLASS 1500									CLASS 2500								
		L			d	H1	H2	EN ISO 5211	(KG)		L			d	H1	H2	EN ISO 5211	(KG)	
NPS	DN	1/RF	2	1/RTJ					1/RF	2	1/RF	2	1/RF					2	1/RTJ
2	50	368	368	371	49	113	118	F12	59	35	451	451	454	49	120	170	F14	118	70
2 1/2	65	419	419	422	62	125	153	F14	94	66	508	508	514	62	130	193	F16	135	85
3	80	470	470	473	74	138	170	F14	109	81	578	578	584	74	150	210	F16	152	98
4	100	546	546	549	100	171	193	F16	181	161	673	673	683	100	180	270	F25	362	322
6	150	705	705	711	146	222	300	F16	400	300	914	914	927	146	230	300	F25	750	675
8	200	832	832	841	194	280	350	F25	735	615	1022	1022	1038	194	290	350	F30	1970	1660
10	250	991	991	1000	241	340	427	F25	1120	925	1270	1270	1292	241	350	427	F30	2990	2490
12	300	1130	1130	1146	289	370	470	F30	1550	1300	1422	1422	1445	289	446	470	F35	4130	3450
14	350	1257	1257	1276	318	499	522	F30	1915	1600	-	-	-	-	-	-	-	-	-
16	400	1384	1384	1407	362	558	598	F35	2350	1950	-	-	-	-	-	-	-	-	-
18	450	-	-	-	-	-	-	-	-	-	-	-	-	-	-	-	-	-	-
20	500	-	-	-	-	-	-	-	-	-	-	-	-	-	-	-	-	-	-

DIMENSIONS OF THE THREADED EXECUTION

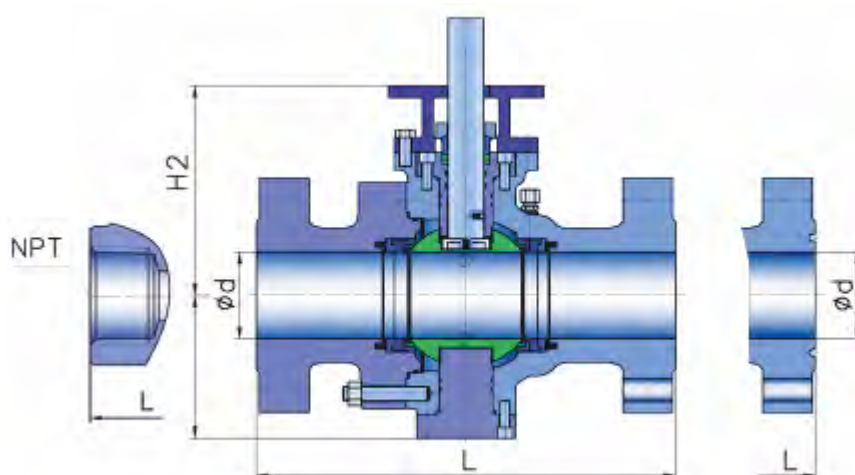

NPS	Thread dimension G	Class 150, 300		Class 600		Class 900	
		Ød	L	Ød	L	Ød	L
1/2"	1/2	15	75	15	85	15	130
3/4"	3/4	20	80	20	95	20	130
1"	1"	25	90	25	105	25	160
1 1/2"	1 1/2"	40	120	38	130	38	168
2"	2"	50	140	49	150	49	185
2 1/2"	2 1/2"	65	185	62	185	---	---
3"	3"	80	205	74	205	---	---
4"	4"	100	240	100	240	---	---
6"	6"	150	270	---	---	---	---

BALL VALVES

TYPE K84

TYPE DESIGNATION

K84 ABC DEF M Class/S

A FACE-TO- FACE DIMENSION

- 1 Short
- 2 Long

D FLOW DIRECTION

- 1 Straight, full bore
- 2 Straight, reduced bore

F CONTROL

- 1 By hand lever
- 2 Hand wheel with gearbox
- 3 Electric actuator
- 4 Electric actuator with gearbox
- 5 Pneumatic actuator
- 6 Other actuator
- 9 Without control

B SEATS EXECUTION

- 1 Polymer
- 2 Polymer + secondary sealing by paste
- 3 Polymer + fire safe
- 4 Polymer + fire safe + secondary sealing by paste
- 5 Metal + O - ring
- 6 Metal + O - ring + secondary sealing by paste
- 7 Metal + O - ring + fire safe

M BODY MATERIAL

- 0 Stainless steel
- 2 Cast alloy steel
- 3 Forged alloy steel
- 4 Forged carbon steel
- 5 Cast carbon steel

C CONTROL STEM SEALING METHOD

- 1 O - ring
- 2 O - ring+graphite
- 3 O - ring + graphite packing
- 4 V-shaped PTFE
- 5 Graphite packing

E CONNECTION INTO PIPE

- 1 Flanged ends
- 2 Welded ends
- 3 Threaded ends
- 8 Combined

S SPECIAL EXECUTION

- DPE** Seats with double piston effect
- AS** Antistatic design
- LT** Low temperature design





Range DN: 25 ~ 1000



Range PN: 16 ~ 100



PED 97/23/EC
PED 2014/68/EU



TR TS 10/11,
12/11, 32/11



EN 12 569
CERTIFICATE



CERTIFICATE
API 607, 6FA

Operating temperature: -196 °C ~ 550 °C

Connection into piping: Flanged, welded ends, threaded ends, combined execution



DESCRIPTION

K86 ball valves are controlled shut-off valves. They are designed to stop, regulate or allow the flow of the medium by external operation, either manually or via the installed drive. The ball valves allow the medium to flow in both directions. Their construction is designed to prevent the build-up of sediment in the flow channel which would otherwise hinder the valve operation. These ball valves are designed and manufactured to ensure maximum service life and reliability.

MATERIAL SPECIFICATION

K86 ball valves are made from carbon, alloy and stainless steels. The material type can be adjusted according to the customer's request to optimally suit the operating conditions.

APPLICATION

K81 ball valves are suitable for various liquids, gases and steam.

BASIC STANDARDS FOR DESIGN

Basic design

EN 1983

Pressure-temperature rating

EN 12 516 - 1

Testing

EN 12 266 - 1, 2

Face-to-face dimensions

EN 558, EN 12 982

Dimensions of the welded ends

EN 12 627

Top Flange dimensions

EN ISO 5211

Flange dimensions

EN 1092 - 1, GOST 12815-80

Special

NACE MR-0175

CONTROL BALL VALVES

TYPE K86

MATERIAL SPECIFICATION

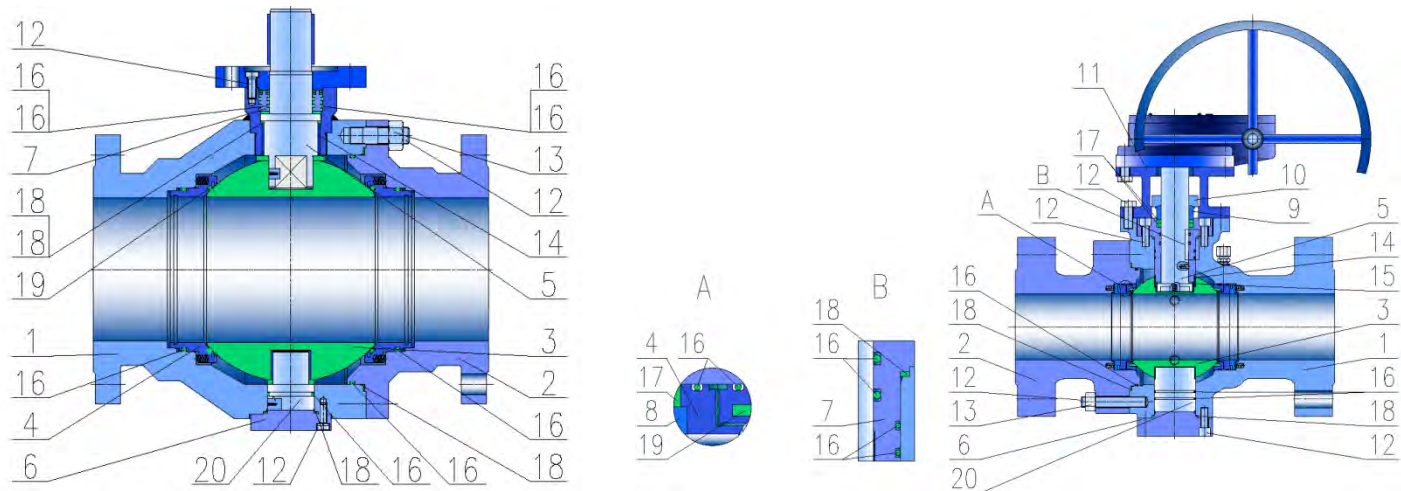

Pos	Designation	Foundry execution						Forged execution					
		WCB	LCB, LCC	CF3	CF3M	CF8	CF8M	LF2	A105	1.4541	F316L	F304	F316
1	Body	A216 WCB	A352 LCB, LCC	A351 F3	A351 CF3M	A351 CF8	A351 CF8M	A350 LF2	A105	1.4541	A182 F316L	A182 F304	A182 F316
2	Bonnet	A216 WCB	A352 LCB, LCC	A351 CF3	A351 CF3M	A351 CF8	A351 CF8M	A350 LF2	A105	1.4541	A182 F316L	A182 F304	A182 F316
3	Ball	A105 + ENP (Cr), A350 LF2 + ENP (Cr)	A352 LCB, LCC + ENP (Cr)	A351 CF3, A182 F304L	A351 CF3M, A182 F316L	A351 CF8, A182 F304	A351CF8 M, A182 F316	A350 LF2 + ENP (Cr)	A105 + ENP (Cr)	1.4541	A351 CF3M, A182 F316L	A351 CF8, A182 F304	A351 CF8M, A182 F316
4	Seat	A105 + ENP (Cr), A350 LF2 + ENP (Cr)	A182 F6a	A182 F304L	A182 F316L	A182 F304	A182 F316	A350 LF2 + ENP (Cr)	A105 + ENP (Cr)	1.4541	A182 F316L	A182 F304	A182 F316
5	Upper Stem	A182 F6a	A182 F6a	A182 F304L	A182 F316L	A182 F304	A182 F316	A182 F6a	A182 F6a	1.4541	A182 F316L	A182 F304	A182 F316
6	Bottom Cover	A105, A350 LF2	A182 F6a	A182 F304L	A182 F316L	A182 F304	A182 F316	A350 LF2	A105	1.4541	A182 F316L	A182 F304	A182 F316
7	Top Cover	A105, A350 LF2	A182 F6a	A182 F304L	A182 F316L	A182 F304	A182 F316	A350 LF2	A105	1.4541	A182 F316L	A182 F304	A182 F316
8	Thrust Ring of The Seat	A105 + ENP (Cr), A350 LF2 + ENP (Cr)	A182 F6a	A182 F304L	A182 F316L	A182 F304	A182 F316	A350 LF2 + ENP (Cr)	A105 + ENP (Cr)	1.4541	A182 F316L	A182 F304	A182 F316
9	Thrust Ring	A182 F6a	A182 F6a	A182 F304L	A182 F316	A182 F304	A182 F316	A182 F6a	A182 F6a	1.4541	A182 F316L	A182 F304	A182 F316
10	Gland Flange	A216 WCB	A352 LCB, LCC	A351 CF3	A351 CF3M	A351 CF8	A351 CF8M	A350 LF2	A105	1.4541	A182 F316L	A182 F304	A182 F316
11	Yoke	A216 WCB	A352 LCB, LCC	A351 CF3	A351 CF3M	A351 CF8	A381 CF8M	-	-	-	-	-	-
12	Bolt	A193 B7	A320 L7	A193 B8	A193 B8M	A193 B8	A193 B8M	25CrMo4	A193 B7	A2 - 70	A193 B8M	A193 B8	A193 B8M
13	Nut	A194 2H	A194 4	A194 8	A194 8M	A194 8	A194 8M	A2 - 70	A194 2H	A2 - 70	A194 8M	A194 8	A194 BM
14	Bushing	stainless steel + PTFE, bronze											
15	Washer	stainless steel + PTFE, bronze											
16	O-Ring	NITRIL, VITON, NBR, HNBR, EPDM											
17	Sealing Ring	graphite											
18	Gasket	graphite, graphite + stainless steel											
19	Seat Ring	NYLON, DEVLON, PTFE, RPTFE, PEEK, NITRIL, VITON, NBR, HNBR, EPDM											
20	Bottom Stem	A182 F6a	A182 F6a	A182 F304L	A182 F316L	A182 F304	A182 F316	A182 F6a	A182 F6a	1.1.4541	A182 F316L	A182 F304	A182 F316

CONTROL BALL VALVES

TYPE K86

DIMENSIONS

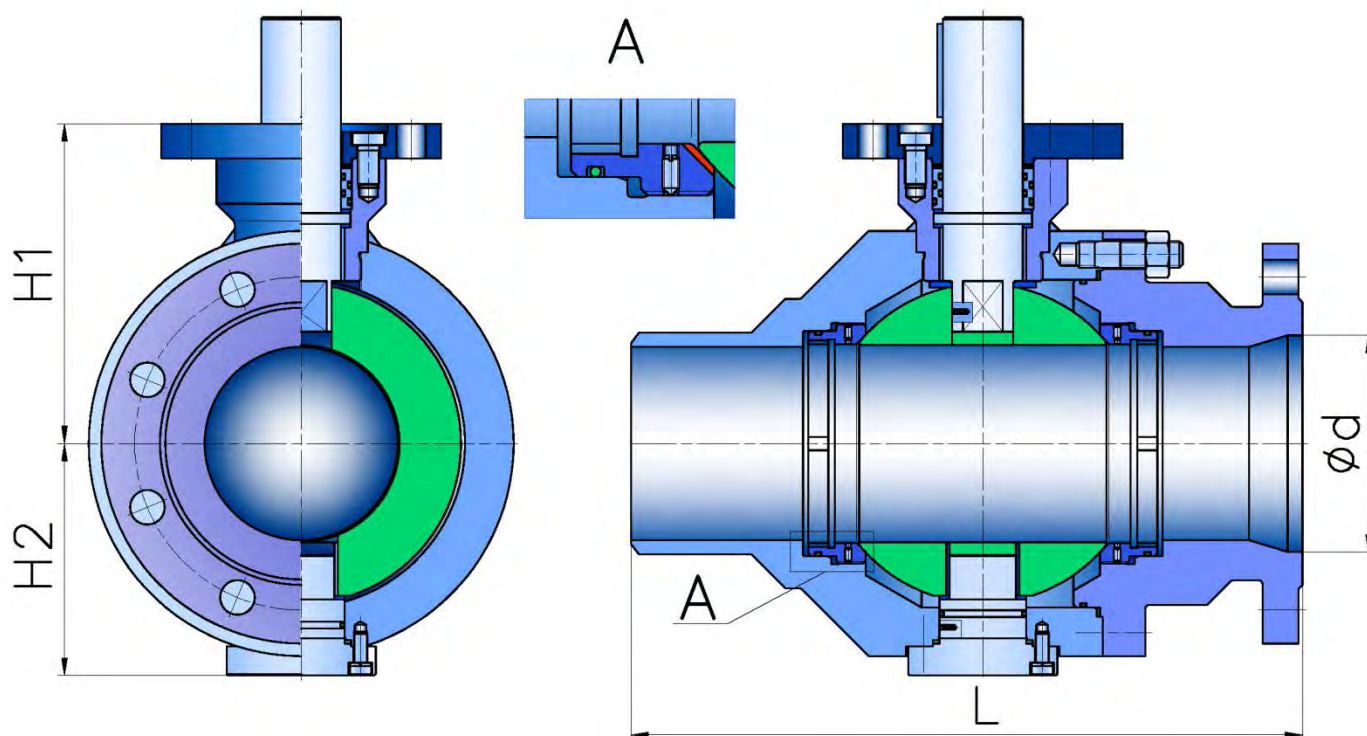

ACCORDING TO DIN STANDARDS-FLANGED

DN	PN 16, 25						PN 40						PN 63						PN 100					
	FLG	d	H1	H2	EN ISO 5211	(KG)	FLG	d	H1	H2	EN ISO 5211	(KG)	FLG	d	H1	H2	EN ISO 5211	(kg)	FLG	d	H1	H2	EN ISO 5211	(KG)
25	160	28	101	68	F07	5	160	28	101	68	F 07	5	160	28	101	68	F07	14	160	28	101	68	F07	18
50	230	54	119	107	F07	19	230	54	119	107	F 07	18	230	54	119	107	F07	30	230	52	119	107	F07	36
65	290	70	170	110	F10	28	290	70	170	110	F 10	25	290	69	170	110	F10	42	290	66	170	110	F10/ F12	52
80	310	82	215	118	F12	32	310	82	215	118	F 12	30	310	80	215	118	F12	55	310	78	215	118	F12	72
100	350	107	218	153	F12	53	350	107	218	153	F 12	95	350	100	218	153	F12	86	350	101	218	153	F12/ F14	104
125	400	131	229	170	F14	79	400	131	229	170	F 14	120	400	125	229	170	F14	154	400	124	229	170	F14/ F16	162
150	450	159	266	190	F16	100	450	159	266	193	F 16	200	450	150	266	193	F16	225	450	149	266	193	F16/ F25	238
200	550	207	312	210	F16	172	550	207	312	210	F 16	246	550	203	312	210	F25	354	550	194	312	210	F25	448
250	650	259	475	270	F25	284	650	259	475	270	F 25	308	650	253	475	270	F30	604	650	241	475	270	F30	660
300	750	308	510	340	F25	494	750	308	510	340	F 25	512	750	299	510	340	F30	830	750	288	510	340	F30	1070
350	850	340	355	380	F25	713	850	340	355	380	F 25	790	850	337	380	400	F30	1110	850	324	380	400	F30	1720
400	950	389	415	440	F25	1000	950	389	415	440	F 25	1490	950	387	430	450	F30	1910	950	387	430	450	F30	2610
500	1150	488	490	515	F25	1498	1150	488	490	515	F 25	1720	1150	489	500	540	F30	3120	1150	489	500	540	F30	4397
600	1350	588	600	605	F30	2540	1350	588	600	605	F 30	2770	1350	591	620	620	F 35	4640	1350	591	620	620	F 35	7035
700	1550	686	675	683	F35	3825	1550	686	675	683	F 35	3995	1550	686	675	690	F 35	8010	-	-	-	-	-	-
800	1750	785	760	775	F35	6230	1750	785	760	775	F 35	7176	1750	781	785	815	F 35	11656	-	-	-	-	-	-
900	1950	882	835	850	F35	8273	1950	882	835	850	F 35	9988	-	-	-	-	-	-	-	-	-	-	-	-
1000	2150	981	930	945	F35	11084	2150	981	930	945	F 35	11735	-	-	-	-	-	-	-	-	-	-	-	-

CONTROL BALL VALVES

TYPE K86

ACCORDING TO DIN STANDARDS-FLANGED

DN	PN 16, 25						PN 40						PN 63						PN 100					
	L	d	H1	H2	EN ISO 5211	(KG)	L	d	H1	H2	EN ISO 5211	(KG)	L	d	H1	H2	EN ISO 5211	(KG)	L	d	H1	H2	EN ISO 5211	(KG)
25	270	28,5	101	68	F07	5	270	28,5	101	68	F07	5	270	28,5	101	68	F07	14	270	27,9	101	68	F07	18
50	300	54,5	119	107	F07	19	300	54,5	119	107	F07	18	300	52,3	119	107	F07	30	300	51,3	119	107	F07	36
65	360	70,3	170	110	F10	28	360	70,3	170	110	F10	25	360	68,1	170	110	F10	42	360	66,1	170	110	F10 / F12	52
80	390	82,5	215	118	F12	32	390	82,5	215	118	F12	30	390	79,9	215	118	F12	55	390	77,7	215	118	F12	72
100	450	107,1	218	153	F12	53	450	107,1	218	153	F12	95	450	105,3	218	153	F12	86	450	100,3	218	153	F12 / F14	104
125	525	131,7	229	170	F14	79	525	131,7	229	170	F14	120	525	127,8	229	170	F14	154	525	123,7	229	170	F14 / F16	162
150	600	159,3	266	190	F16	100	600	159,3	266	193	F16	200	600	155,7	266	193	F16	225	600	148,3	266	193	F16 / F25	238
200	600	206,5	312	210	F16	172	600	206,5	312	210	F25	246	600	204,9	312	210	F25	354	600	194,1	312	210	F25	448
250	730	258,5	475	270	F25	284	730	258,8	475	270	F30	308	730	255,4	475	270	F30	604	730	241	475	270	F30	660
300	850	307,9	510	340	F25	494	850	307,9	510	340	F30	512	850	301,9	510	340	F30	830	850	278,9	510	340	F30	1070
350	980	337,6	380	355	F25	510	980	337,6	380	355	F30	740	980	330,6	400	380	F30	1700	980	315,6	400	380	F30	2240
400	1100	384,4	440	415	F25	750	1100	384,4	450	430	F30	1030	1100	378,4	450	430	F30	1970	1100	366,4	450	430	F30	2770
500	1250	480	515	490	F25	1190	1250	480	540	500	F30	1540	1250	472	540	500	F30	3250	1250	458	540	500	F30	3740
600	1143	-	605	600	F30	2100	1143	-	620	620	F30	2600	1397	-	620	620	F35	4604	1143	-	620	615	F35	5560
700	1346	-	683	675	F35	3000	1346	-	690	675	F35	3900	1549	-	690	675	F40	6621	-	-	-	-	-	-
800	1397	-	775	760	F35	6155	1397	-	815	785	F35	7006	1651	-	815	785	F40	8917	-	-	-	-	-	-
900	1524	-	850	835	F35	8267	1524	-	890	905	F40	9208	-	-	-	-	-	-	-	-	-	-	-	-
1000	1727	-	945	930	F35	10720	1727	-	955	940	F40	11820	-	-	-	-	-	-	-	-	-	-	-	-

DN	KVS m3/h	PN 16, 25						PN 40					
		L	d	H1	H2	EN ISO 5211	(KG)	L	d	H1	H2	EN ISO 5211	(KG)
25	65	210	25	101	68	F07	5	210	25	101	68	F07	5
50	320	230	49	119	107	F07	19	230	48	119	107	F07	18
65	570	290	66	170	110	F10	28	290	66	170	110	F10	25
80	850	310	78	215	118	F12	32	310	78	215	118	F12	30
100	1420	350	96	218	153	F12	53	350	96	218	153	F12	95
125	2020	400	121	229	170	F14	79	400	120	229	170	F14	120
150	3400	480	146	266	190	F16	100	480	145	266	193	F16	200
200	6075	550	202	312	210	F25	172	550	200	312	210	F25	246
250	10600	650	254	475	270	F30	284	650	252	475	270	F30	308
300	16800	750	303	510	340	F30	494	750	301	510	340	F30	512

DN	KVS m3/h	PN 63						PN 100					
		L	d	H1	H2	EN ISO 5211	(KG)	L	d	H1	H2	EN ISO 5211	(KG)
25	65	210	25	101	68	F07	14	210	25	101	68	F07	18
50	320	230	47	119	107	F07	30	230	45	119	107	F07	36
65	570	290	64	170	110	F10	42	290	62	170	110	F10 / F12	52
80	850	310	77	215	118	F12	55	310	75	215	118	F12	72
100	1420	350	94	218	153	F12	86	350	92	218	153	F12 / F14	104
125	2020	400	118	229	170	F14	154	400	112	229	170	F14 / F16	162
150	3400	480	142	266	193	F16	225	480	136	266	193	F16 / F25	238
200	6075	550	198	312	210	F25	354	550	190	312	210	F25	448
250	10600	650	246	475	270	F30	604	650	236	475	270	F30	660
300	16800	750	294	510	340	F30	830	750	284	510	340	F30	1070

CONTROL BALL VALVES

TYPE K86

TYPE DESIGNATION

K86 ABC DEF M PN/S
A FACE-TO- FACE
DIMENSION

- 1 Short
- 2 Long

BODY DESIGN

- 2 Two pieces
- 3 Three pieces

F CONTROL

- 1 By hand lever
- 2 Hand wheel with gearbox
- 3 Electric actuator
- 4 Electric actuator with gearbox
- 5 Pneumatic actuator
- 6 Other actuator
- 9 Without control

D FLOW DIRECTION

- 1 Straight, full bore
- 2 Straight, reduced bore

M BODY MATERIAL

- 0 Stainless steel
- 2 Cast alloy steel
- 3 Faged alloy steel
- 4 Forged carbon steel
- 5 Cast carbon steel

C CONTROL STEM SEALING METHOD

- 1 O- ring
- 2 O – ring + graphite (fire safe)
- 3 O – ring + Graphite packing
- 4 V-shaped PTFE O - ring
- 5 Graphite packing

E CONNECTION INTO PIPE

- 1 Flanged
- 2 Welded ends
- 8 Combined

B SEATS EXECUTION

- 9 Metal - Metal

S SPECIAL EXECUTION

- AS Antistatic design
- LT Low temperature design





Range DN: 50 ~ 1200



PED 97/23/EC
PED 2014/68/EU



TR TS 10/11,
12/11, 32/11



Range PN: 16 ~ 100

Operating temperature: -196 °C ~ 550 °C

Connection into piping: Flanged, welded ends, threaded ends, combined execution



DESCRIPTION

K89 (all-welded design) ball valves are controlled shut-off valves. They are designed to stop or allow the flow of the medium by external operation, either manually or via the installed drive. The ball valves allow the medium to flow in both directions. Their construction is designed to prevent the build-up of sediment in the flow channel which would otherwise hinder the valve operation. These ball valves are designed and manufactured to ensure maximum service life and reliability.

MATERIAL SPECIFICATION

K89 ball valves are made from carbon, alloy and stainless steels. The material type can be adjusted according to the customer's request to optimally suit the operating conditions.

APPLICATION

K89 ball valves are suitable for various liquids, gases and steam.

BASIC STANDARDS FOR DESIGN

Basic design

EN 1983

Pressure-temperature rating

EN 12 516 - 1

Testing

EN 12 266 - 1, 2

Face-to-face dimensions

EN 12 982

Dimensions of the welded ends

EN 12 627

Top Flange dimensions

EN ISO 5211

Flange dimensions

EN 1092 - 1

Special

NACE MR-0175

ALL WELDED BALL VALVES

TYPE K89

STRUCTURAL DESIGN

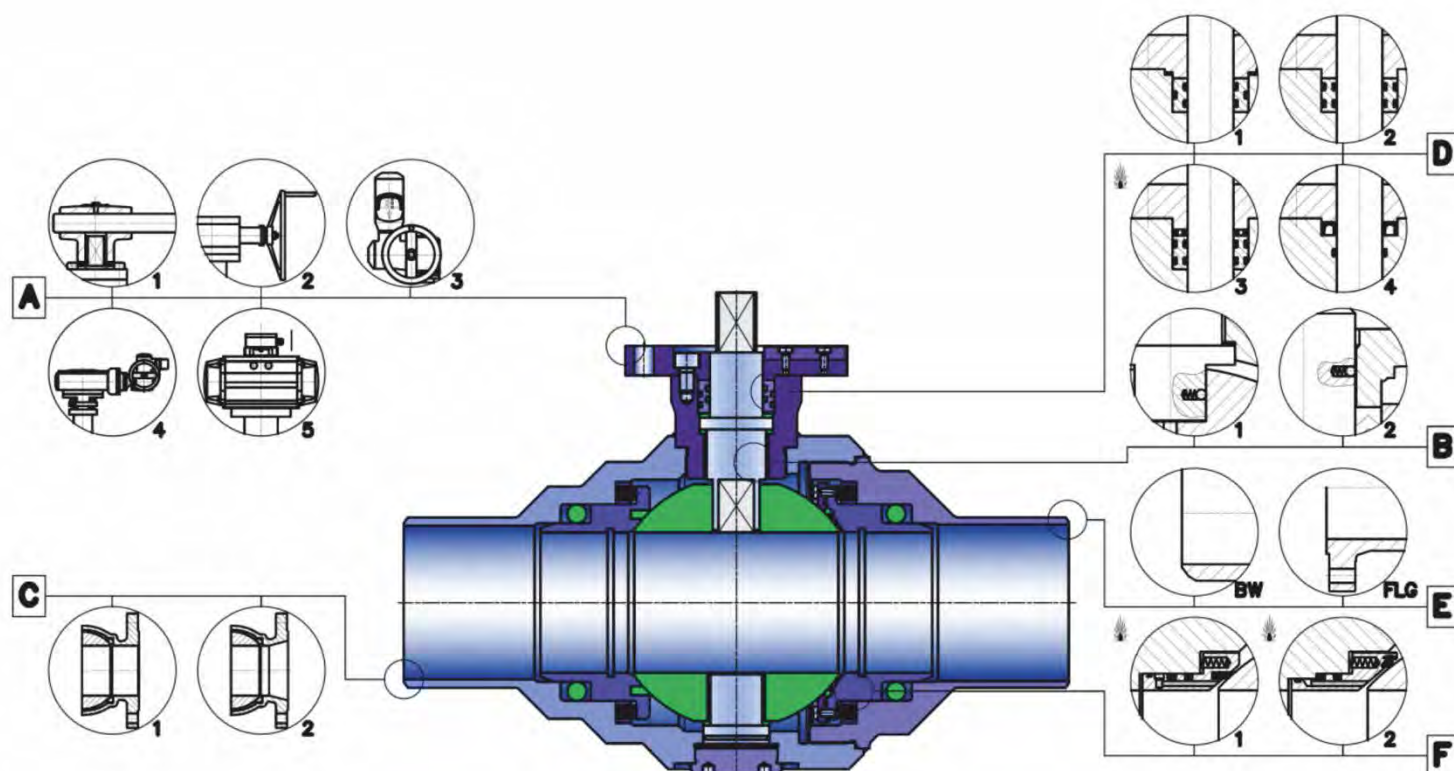

A - control

- by hand lever
- gear box + hand wheel
- electric actuator
- electric actuator + gear box
- pneumatic actuator

B – special execution

- antistatic design

C – flow direction

- straight, full bore
- straight, reduced bore

D – control stem sealing method

- dynamic – 2x O - ring, static O - ring + Graphite
- dynamic – 2x O - ring, static– 2x O - ring
- dynamic - 2xO-ring + Graphite (Fire safe design)
- static - 2x O - ring + Graphite (Fire safe design)
- O-ring + V-shaped PTFE ring packing

E – connection into piping

- flanged
- welded ends
- welded ends according to customer's requirements

F- Seats execution

- The seats are made with single or double piston effect, with possibilities of greasing and in Fire safe design execution. Also the seats are supplied with „DBB“ (double block and bleed) execution. The seats with single piston effect have possibility to reduce the pressure in an intermediate space between the ball and body. The seats with double piston effect are pressed to the ball also by the fluid pressure in the intermediate space, what is ensuring hermetic closure at the inlet and the outlet side of the valve. For restriction of the pressure in the intermediate space of the body an overflow device is mounted..

ALL WELDED BALL VALVES

TYPE K89

MATERIAL SPECIFICATION – WELEDED ENDS EXECUTION

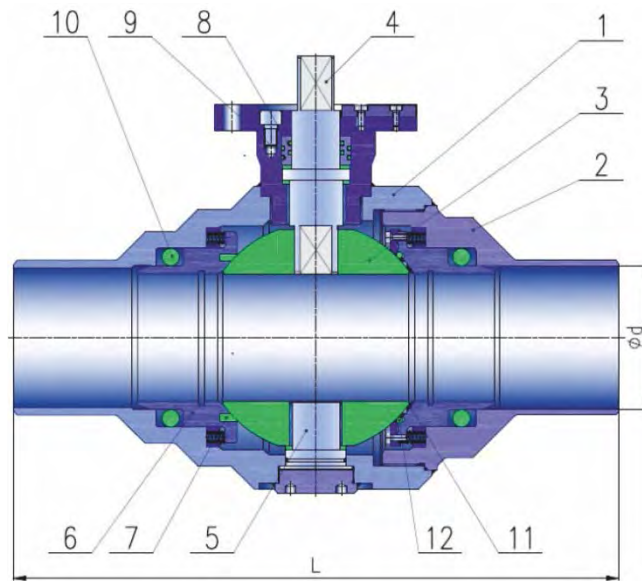

Pos.	Designation	Material									
		A350 LF2	A105	A182F5	A182F9	A182F304	A182F316				
1	Body	A350 LF2	A105	A182F5	A182F9	A182F304	A182F316	1.4541	1.4401	1.4404	
2	Bonnet	A350 LF2	A105	A182F5	A182F9	A182F304	A182F316	1.4541	1.4401	1.4404	
3	Ball	X12Cr13 + Cr (ENP)	X12Cr13 + Cr (ENP)	A182F5 + Cr (ENP)	A182F9 + Cr (ENP)	A182F304 + Cr (ENP)	A182F316 + Cr (ENP)	1.4541 + Cr (ENP)	1.4401 + Cr (ENP)	1.4404 + Cr (ENP)	
4	Upper Stem	X12Cr13	X12Cr13	A182F5	A182F9	A182F304	A182F316	1.4541	1.4401	1.4404	
5	Bottom stem	X12Cr13	X12Cr13	A182F5	A182F9	A182F304	A182F316	1.4541	1.4401	1.4404	
6	Seat	A350 LF2 + STL	A105 + STL	A182F5	A182F9	A182F304	A182F316	1.4541	1.4401	1.4404	
7	Seat ring	PTFE									
8	O-ring	NBR, HNBR, EPDM, Viton, PTFE									
9	O-ring	NBR, HNBR, EPDM, Viton, PTFE									
10	O-ring	NBR, HNBR, EPDM, Viton, PTFE									
11	Overlay	Ni, Stelit 6									
12	Seat ring	NBR, HNBR, EPDM, VITON, Graphite									

DIMENSIONS – WELEDED ENDS EXECUTION

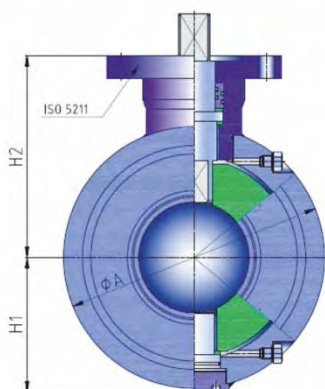

DN	PN 40						PN 63						PN 100					
	FLG	d	H1	H2	EN ISO 5211	(KG)	FLG	d	H1	H2	EN ISO 5211	(KG)	FLG	d	H1	H2	EN ISO 5211	(KG)
50	300	54,5	70	204	F07	21	300	52,3	69	138	F07	28	300	52,3	69	138	F07	28
65	360	70,3	100	305	F10	33	360	68,1	100	160	F10	41	360	66,1	100	160	F10 / F12	43
80	390	82,5	110	335	F12	54	390	79,9	107	181	F12	58	390	78,9	107	181	F12	64
100	450	107,1	116	423	F12	66	450	105,3	116	209	F12	72	450	103,1	116	209	F12 / F14	75
125	525	131,7	150	444	F14	98	525	127,8	150	229	F14	115	525	127,1	150	229	F14 / F16	117
150	600	159,3	180	526	F16	145	600	155,7	180	266	F16	170	600	152,3	180	266	F16 / F25	195
200	600	206,5	197	619	F25	210	600	204,9	197	312	F25	265	600	201,5	197	312	F25	295
250	730	258,8	250	855	F30	285	730	255,4	250	475	F30	380	730	253	250	475	F30	470
300	850	307,9	300	940	F30	445	850	301,9	300	510	F30	535	850	298,9	300	510	F30	650

ALL WELDED BALL VALVES

TYPE K89

MATERIAL SPECIFICATION – FLANGED EXECUTION

Pos.	Designation	Material
1	Body	P265 GH
2	Ball	1.4301
3	Seat	PTFE
4	Ring	P265 GH + ENP
5	O-ring	VITON
6	Spring	INCONEL X750
7	Upper Stem	1.4301
8	Bottom stem	1.4301
9	Bushing	PTFE
10	O-ring	VITON
11	Gland	PTFE
12	Nut	P265 GH

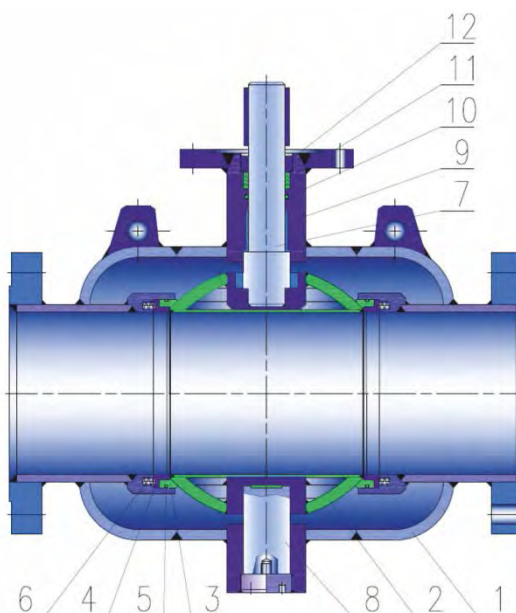

DIMENSIONS – FULL BORE EXECUTION

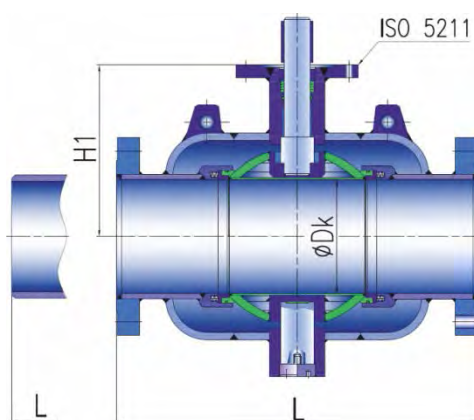

DN	PN 16							PN 25						
	FLG	Dk	H1	EN ISO 5211	Kv m3/h	(KG)		FLG	Dk	H1	EN ISO 5211	Kv m3/h	(KG)	
						RF	BW						RF	BW
200	630	200	464	F16	8650	170	150	630	200	464	F16	8650	179	150
250	710	250	491	F16	14705	228	200	710	250	491	F16	14705	240	200
300	750	300	525	F25	20760	303	265	750	300	525	F25	20760	318	265
350	860	350	547	F25	24220	479	423	860	350	547	F25	24220	507	423
400	970	400	599	F25	31140	677	605	970	400	599	F25	31140	715	605
500	1150	500	646	F30	49305	1227	1099	1150	500	646	F30	49305	1267	1099
600	1380	600	725	F35	64875	2472	2280	1380	600	725	F35	64875	2535	2280
700	1525	700	795	F35	80445	3390	3160	1525	700	795	F35	80445	-	3160
800	1650	779	820	F40	95583	4426	4110	1650	779	820	F40	95583	-	4110
900	1750	876	902	F40	115045	6106	5666	1750	876	902	F40	115045	-	5666
1000	1850	976	963	F40	129750	7794	7260	1850	976	963	F40	129750	-	7260

DIMENSIONS – REDUCED BORE EXECUTION

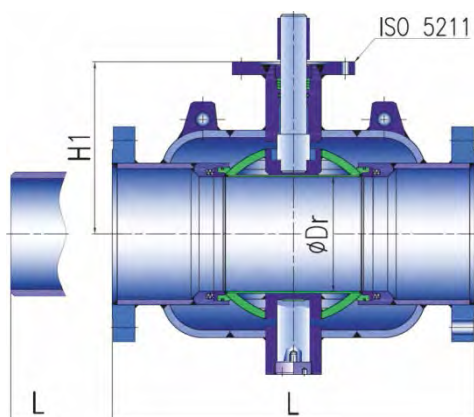

DN	PN 16							PN 25						
	FLG	Dr	H1	EN ISO 5211	Kv m3/h	(KG)		FLG	Dr	H1	EN ISO 5211	Kv m3/h	(KG)	
						RF	BW						RF	BW
250	630	200	464	F16	3028	98	70	630	200	464	F16	3028	110	70
300	710	250	491	F16	4723	184	146	710	250	491	F16	4723	199	146
350	750	300	525	F25	6834	258	202	750	300	525	F25	6834	286	202
400	860	350	547	F25	9256	362	290	860	350	547	F25	9256	400	290
450	970	400	599	F25	12110	467	375	970	400	599	F25	12110	504	375
500	970	400	599	F25	15570	648	520	970	400	599	F25	15570	688	520
600	1150	500	646	F30	19030	748	556	1150	500	646	F30	19030	811	556
700	1380	600	725	F35	27248	1271	1041	1380	600	725	F35	27248	-	1041
800	1525	700	795	F35	37195	2736	2420	1525	700	795	F35	37195	-	2420
900	1650	779	820	F40	48440	3750	3310	1650	779	820	F40	48440	-	3310
1000	1750	876	902	F40	61415	4844	4310	1750	876	902	F40	61415	-	4310
1200	1850	976	963	F40	74390	-	4560	1850	976	963	F40	74390	-	4560

ALL WELDED BALL VALVES

TYPE K89

TYPE DESIGNATION

K89 ABC DEF M PN/S

A FACE-TO- FACE DIMENSION

- 1 Short
- 2 Long

BODY DESIGN

- 1 All welded body

D FLOW DIRECTION

- 1 Straight, full bore
- 2 Straight, reduced bore

F CONTROL

- 1 By hand lever
- 2 Hand wheel with gearbox
- 3 Electric actuator
- 4 Electric actuator with gearbox
- 5 Pneumatic actuator
- 6 Other actuator
- 9 Without control

B SEATS EXECUTION

- 1 Polymer
- 2 Polymer + secondary sealing by paste
- 3 Polymer + fire safe
- 4 Polymer + fire safe + secondary sealing by paste
- 5 Metal + O - ring
- 6 Metal + O - ring + secondary sealing by paste
- 7 Metal + O - ring + fire safe

M BODY MATERIAL

- 0 Stainless steel
- 2 Cast alloy steel
- 3 Forged alloy steel
- 4 Forged carbon steel
- 5 Cast carbon steel

C CONTROL STEM SEALING METHOD

- 1 O - ring
- 2 O - ring+graphite
- 3 O - ring + graphite packing
- 4 V-shaped PTFE
- 5 Graphite packing

E CONNECTION INTO PIPE

- 1 Flanged
- 2 Welding-on ends
- 3 Combined

S SPECIAL EXECUTION

- DPE** Seats with double piston effect
- AS** Antistatic design
- LT** Low temperature design





Range DN: 8 ~ 300



PED 97/23/EC
PED 2014/68/EU



TR TS 10/11,
12/11, 32/11



Range PN: 16 ~ 63

Operating temperature: -50 °C ~ 230 °C

Connection into piping: Flanged, welded ends, threaded ends, combined execution



DESCRIPTION

V005 ball valves are controlled shut-off valves. They are designed to stop or allow the flow of the medium by external operation, either manually or via the installed drive. The ball valves allow the medium to flow in both directions. Their construction is designed to prevent the build-up of sediment in the flow channel which would otherwise hinder the valve operation. These ball valves are designed and manufactured to ensure maximum service life and reliability.

MATERIAL SPECIFICATION

V005 ball valves are made from carbon, alloy and stainless steels. The material type can be adjusted according to the customer's request to optimally suit the operating conditions.

APPLICATION

V005 ball valves of this design are suitable for the chemical and food-stuff industries and in processes where the contamination of the working medium by the products of corrosion is not admissible.

BASIC STANDARDS FOR DESIGN

Basic design

EN 1983

Pressure-temperature rating

EN 12 516 - 1

Testing

EN 12 266 - 1, 2

Face-to-face dimensions

EN 558, EN 12 982

Dimensions of the welded ends

EN 12 627

Top Flange dimensions

EN ISO 5211

Flange dimensions

EN 1092 - 1

Special

NACE MR-0175

BALL VALVES

TYPE V005

MATERIAL SPECIFICATION

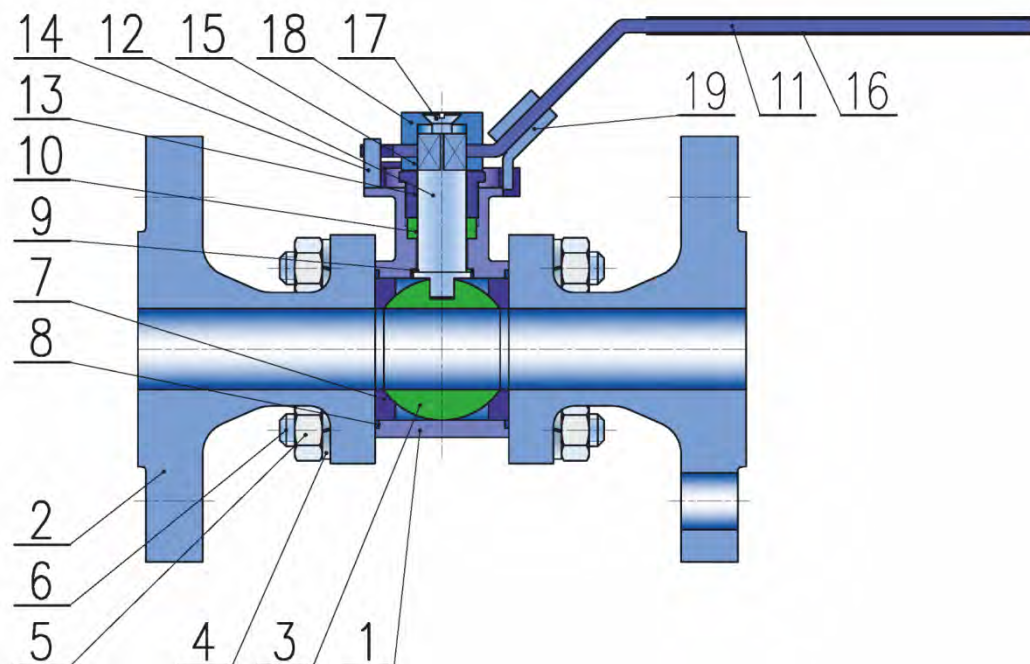

Pos.	Designation	Material		
1	Body	A216 WCB	A351 CF8	A351 CF8M
2	Bonnet	A216 WCB	A351 CF8	A351 CF8M
3	Ball	A351 CF8, 304, 316	A351 CF8	A351 CF8M
4	Spring washer	304		
5	Nut	304		
6	Bolt	304		
7	Seat	PTFE, PTFE + glass, PTFE + graphite, PTFE + stainless steel		
8	Packing	PTFE + stainless steel		
9	Thrust washer	PTFE, PTFE + glass, PTFE + graphite, PTFE + stainless steel		
10	Gland	PTFE + stainless steel		
11	Hand lever	304		
12	Upper Stem	316		
13	Gland nut	304		
14	Stopper	304		
15	Stem washer	304		
16	Plastic cover	Plastic		
17	Lever bolt	304		
18	Lever cover	304		
19	Lock device	304		

BALL VALVES

TYPE V005

DIMENSIONS

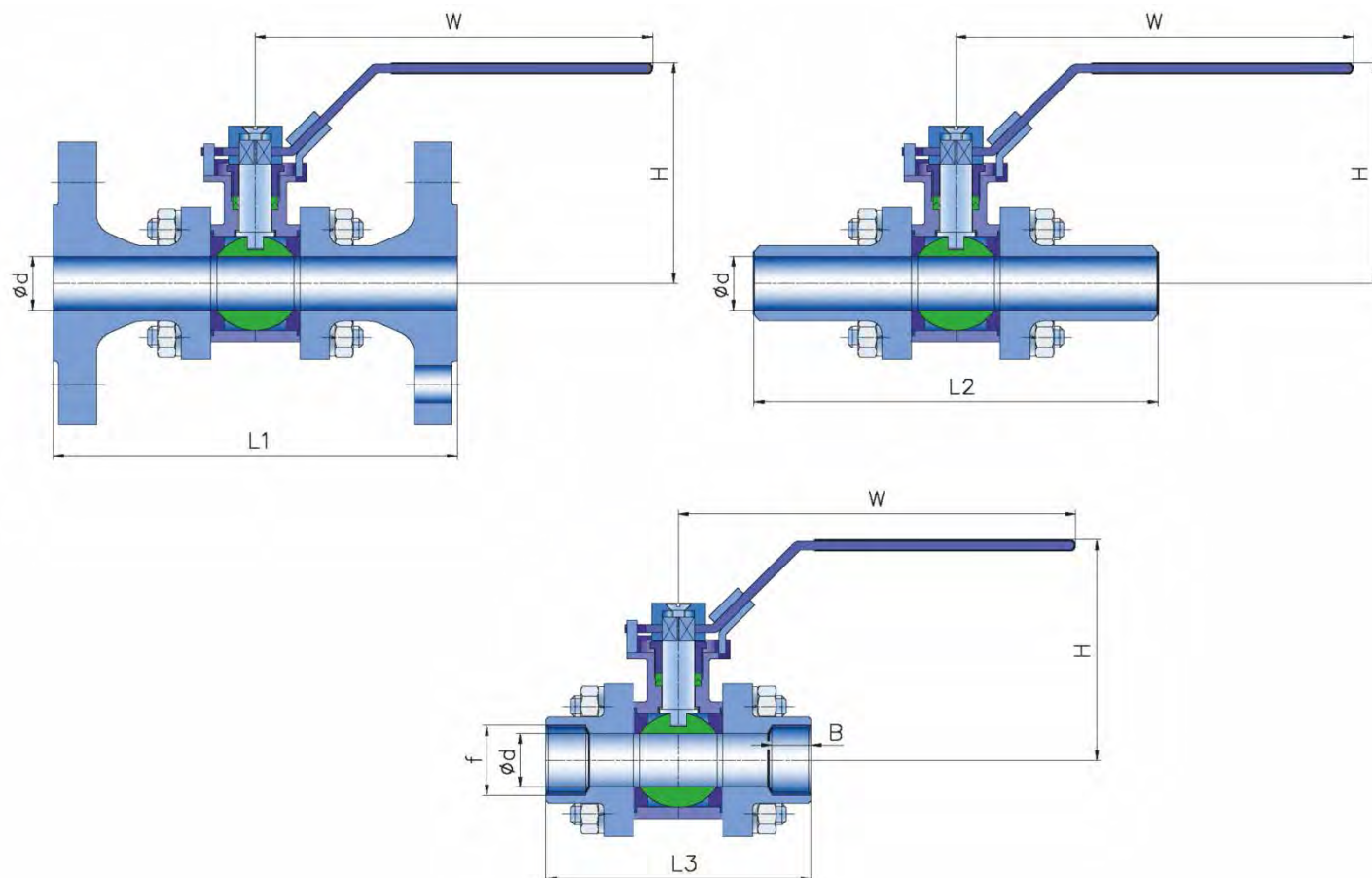

DN	PN 16, 25, 40, 63									
	d	L1	L2	L3	f (Rp)	B	H	W	EN ISO 5211	(kg)
8	11.2	130	65	55	1/4	12	81	126	F 03	1.5
10	12.6	130	70	60	3/8	12	81	140	F 03	2
15	16	130	75	75	1/2	15	84	147	F 03	3
20	20	150	90	80	3/4	17.5	87	147	F 03	4
25	25	160	100	90	1	19.5	93	154	F 04	5
32	32	180	110	110	1 1/4	21.5	99	154	F 04	8
40	38.1	200	125	120	1 1/2	21.5	114	218	F 05	11
50	50.8	230	150	140	2	22	122	218	F 05	15
65	65	290	190	185	2 1/2	27.5	150	252	F 07	20
80	80	310	220	205	3	32	161	252	F 07	29
100	100	350	270	240	4	35	180	292	F 10	48
125	131.7	400	330	-	-	-	210	292	F 10/F 12	67
150	159.3	480	430	260	6	36	240	350	F 12/F 14	95
200	207.5	600	460	-	-	-	295	350	F 14/F 16	170
250	259	730	559	-	-	-	355	390	F 16/F 25	200
300	308	850	635	-	-	-	410	390	F 16/F 25	237

BALL VALVES

TYPE V005

TYPE DESIGNATION

V005 ABC M PN/S

A CONNECTION INTO PIPE F Flanged B Welded T Threaded	B ISO TOP FLANGE - Without M With flange	C LOCK DEVICE OF HAND LEVER - Without L With lock device
M BODY MATERIAL SS Stainless cast AS Cast alloy steel CS Cast carbon steel	S SPECIAL EXECUTION A Antistatic execution S	





Range DN: 8 ~ 300



PED 97/23/EC
PED 2014/68/EU



TR TS 10/11,
12/11, 32/11



Range PN: 16 ~ 63

Operating temperature: -50 °C ~ 230 °C

Connection into piping: Flanged or threaded ends



DESCRIPTION

V006 ball valves are controlled shut-off valves. They are designed to stop or allow the flow of the medium by external operation, either manually or via the installed drive. The ball valves allow the medium to flow in both directions. Their construction is designed to prevent the build-up of sediment in the flow channel which would otherwise hinder the valve operation. These ball valves are designed and manufactured to ensure maximum service life and reliability.

MATERIAL SPECIFICATION

V006 ball valves are made from carbon, alloy and stainless steels. The material type can be adjusted according to the customer's request to optimally suit the operating conditions.

APPLICATION

V006 ball valves of this design are suitable for the chemical and food-stuff industries and in processes where the contamination of the working medium by the products of corrosion is not admissible.

BASIC STANDARDS FOR DESIGN

Basic design

EN 1983

Pressure-temperature rating

EN 12 516 - 1

Testing

EN 12 266 - 1, 2

Face-to-face dimensions

EN 558, EN 12 982

Dimensions of the welded ends

N/A

Top Flange dimensions

EN ISO 5211

Flange dimensions

EN 1092 - 1

Special

NACE MR-0175

BALL VALVES

TYPE V006

MATERIAL SPECIFICATION

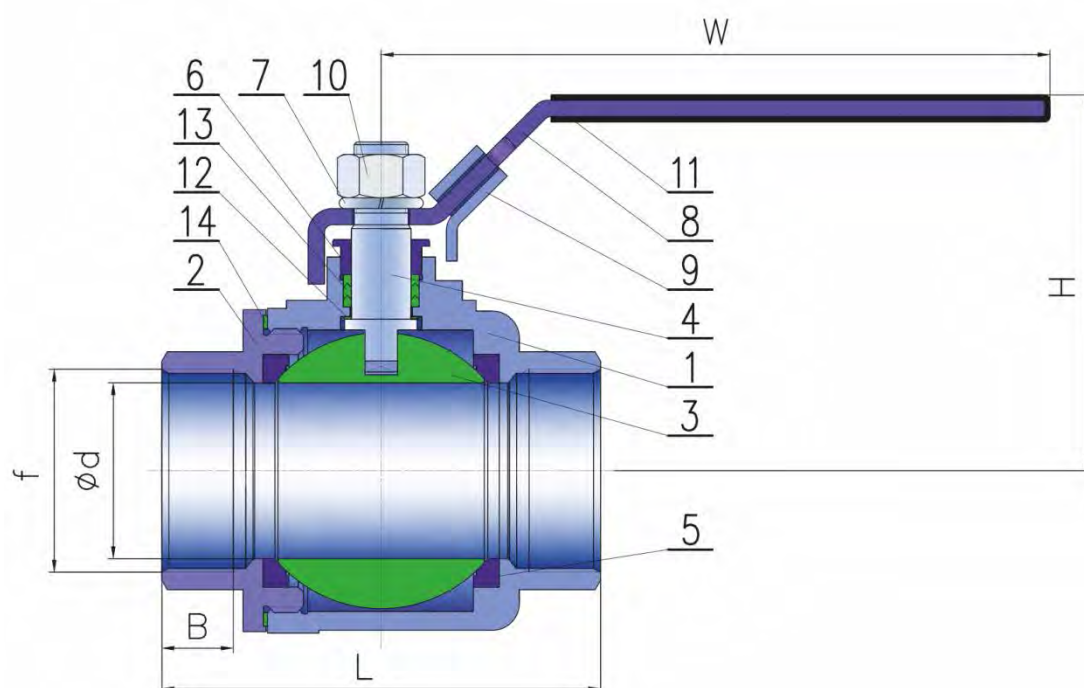

Pos.	Designation	Material		
1	Body	A216 WCB	A351 CF8	A351 CF8M
2	Bonnet	A216 WCB	A351 CF8	A351 CF8M
3	Ball	A351 CF8, 304, 316	A351 CF8	A351 CF8M
4	Upper Stem	316		
5	Seat	PTFE, PTFE + glass, PTFE + graphite, PTFE + stainless steel		
6	Gland flange	316		
7	Washer	304		
8	Lever	304		
9	Locking device	304		
10	Stem nut	304		
11	Cover of lever	Plastic		
12	Thrust washer	304		
13	Stem packing	PTFE, PTFE + glass, PTFE + graphite		
14	Joint gasket	PTFE + stainless steel		

BALL VALVES

TYPE V006

DIMENSIONS

PN 10, PN 16, PN 25, PN 40, PN 63							
DN	d	L	f	B	H	W	(kg)
8	11.2	49	1/4	12	51	95	0.25
10	12.6	49	3/8	12	51	95	0.25
15	16	57	1/2	15	53	95	0.45
20	20	65	3/4	17.5	59	110	0.5
25	25	78	1	19.5	73	135	1.1
32	32	90.5	1 1/4	21.5	78	135	1.6
40	38.1	105	1 1/2	21.5	91	165	2.3
50	50.8	127	2	22	99	165	3.7
65	65	160	2 1/2	27.5	130	215	4.6
80	80	187	3	32	142	215	5.8
100	100	260	4	35	174	325	8.4

TYPE DESIGNATION

V006 ABC M PN/S

<p>A CONNECTION INTO PIPE</p> <p>F Flanged</p> <p>T Threaded</p>	<p>B ISO TOP FLANGE</p> <p>- Without</p> <p>M With flange</p>	<p>C LOCK DEVICE OF HAND LEVER</p> <p>- Without</p> <p>L With lock device</p>
<p>M BODY MATERIAL</p> <p>SS Stainless cast</p> <p>AS Cast alloy steel</p> <p>CS Cast carbon steel</p>	<p>S SPECIAL EXECUTION</p> <p>A Antistatic execution</p> <p>S</p>	



Range NPS: 1/4" ~ 40"



PED 97/23/EC
PED 2014/68/EU



TR TS 10/11,
12/11, 32/11



Range Class: 150 ~ 2500



EN 12 569
CERTIFICATE

Operating temperature: -196 °C ~ 550 °C

Connection into piping: Flanged, welded ends, threaded ends, combined execution



DESCRIPTION

C09 2 gate valves are controlled shut-off valves. They are designed to stop or allow the flow of the medium by external operation, either manually or via the installed drive. They are not intended to regulate the flow of the transported medium. The medium can flow in both directions. These gate valves are designed and manufactured to ensure maximum service life and reliability.

MATERIAL SPECIFICATION

C09 2 gate valves are made from carbon, alloyed and stainless steels. The material type can be adjusted according to the customer's request to optimally suit the operating conditions.

APPLICATION

C09 2 gate valves are mainly suitable for various chemicals and petrochemicals, liquids, gases and steam.

BASIC STANDARDS FOR DESIGN

Basic design

API 602, API 600, ASME B16.34

Pressure-temperature rating

ASME B16.34

Testing

API 598, EN 12 266 - 1, 2

Face-to-face dimensions

ANSI B16.10

Dimensions of the welded ends

ANSI B16.25, ASME B16.11

Top Flange dimensions

EN ISO 5210

Flange dimensions

ANSI B 16.5, ANSI B16.47A

Special

NACE MR-0175

STRUCTURAL DESIGN

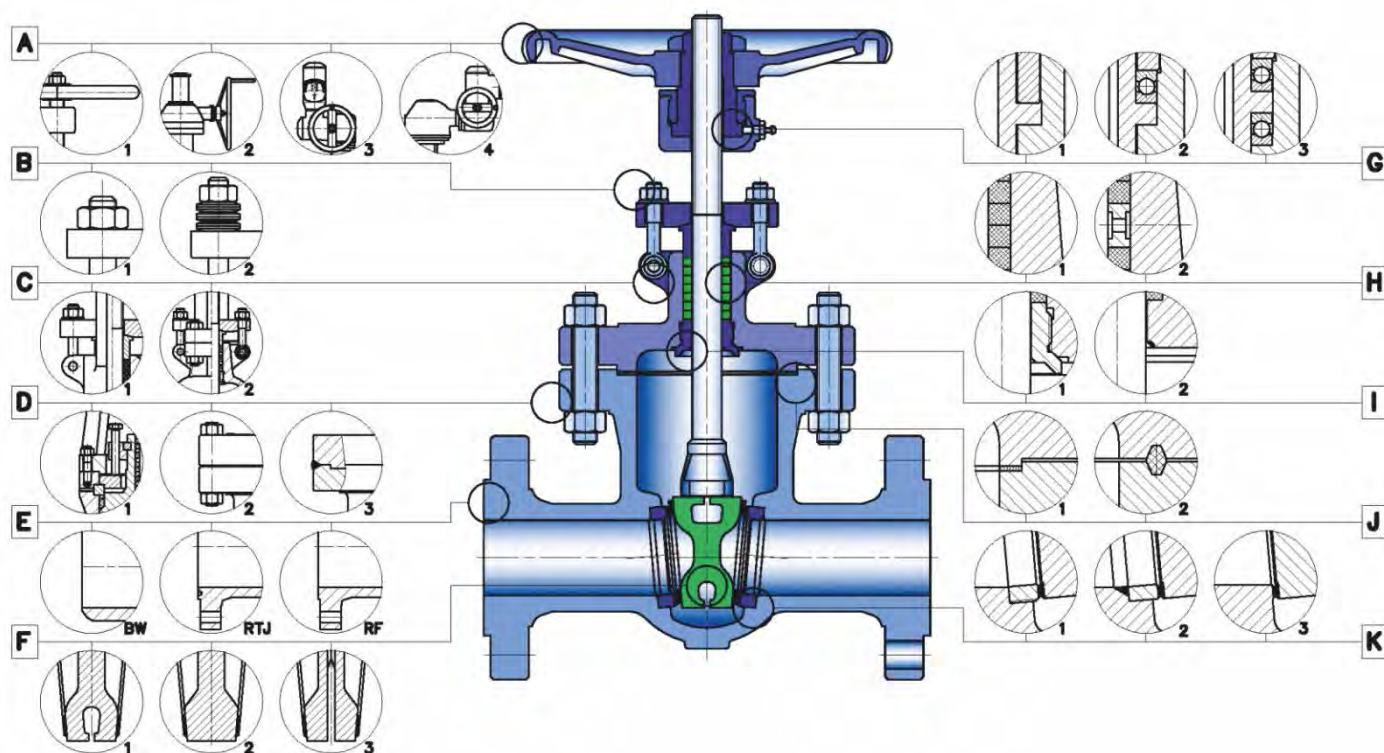
**A - Control**

- hand wheel
- hand wheel + gearbox
- electric actuator
- electric actuator with gearbox

B – Gland compression

- in case of valve operation with cyclic changes in pressure or at high pressures and temperatures, gland compression by means of Belleville springs, which ensure a constant pre-stress in packing, is preferred.

C – Yoke execution

- yoke is the separate detail fixed by bolts to the bonnet
- yoke as integral part of the bonnet (yoke-bonnet)

D - Bonnet execution

- pressure seal bonnet is used for high pressures, temperatures and operation with cyclic changes of pressure
- the bonnet bolted to the body
- the bonnet welded to the body

E – Connection to piping

- flanged
- threaded
- socket welding
- welded ends
- welded ends according to customer's requirements

F – Wedge execution

- solid
- flexible
- split wedge

G - Bedding of stem nut

- friction (sliding) type
- combination of sliding and rolling stem nut bedding
- bedding of stem nut between two axial rolling bearings

H – Execution of gland packing

- standard
- double-stem packing with lantern ring-shall be chosen according to working conditions

I - Back-seat execution

- screwed into the bonnet
- integral part of the bonnet

J - Bonnet sealing

- Class150,300 - by gasket for male-female body/bonnet connection
- Class600,900 – RTJ ring
- Class1500,2500 - by pressure seal bonnet

K - Seats execution

- the seats are screwed into the body
- the seats are inserted into the body and welded on
- the seats consist of a weld deposit on the body

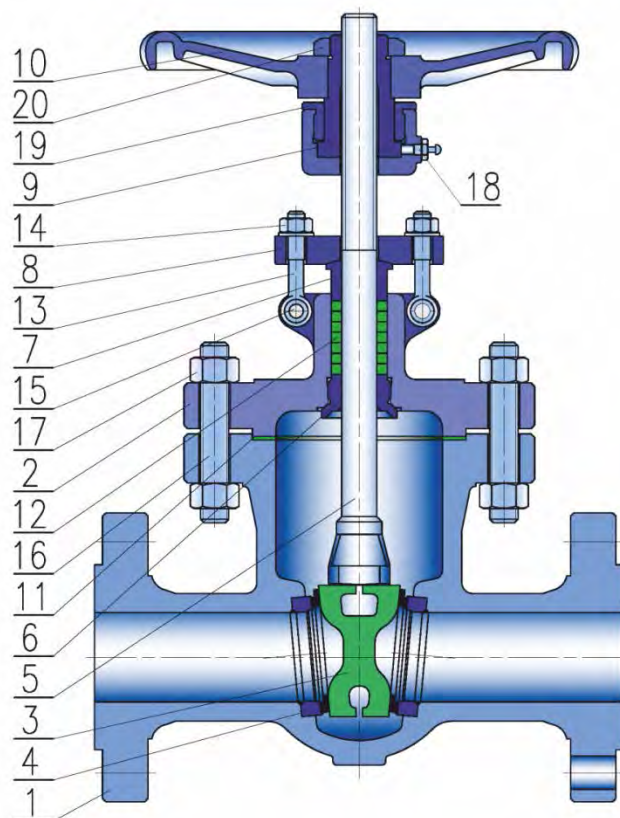
 MATERIAL SPECIFICATION - CAST

Pos.	Designation	WCB	LCC	LCB	WC6	WC9	C5	C12	CF8 / 304	CF8M / 316
1	Body	A216 WCB	A352 LCC	A352 LCB	A217 WC6	A217 WC9	A217 C5	A217 C12	A351 CF8	A351 CF8M
2	Bonnet	A216 WCB	A352 LCC	A352 LCB	A217 WC6	A217 WC9	A217 C5	A217 C12	A351 CF8	A351 CF8M
3	Wedge	A216 WCB + overlay	A352 LCC + overlay	A352 LCB + overlay	A217 WC6 + overlay	A217 WC9 + overlay	A217 C5 + overlay	A217 C12 + overlay	A351 CF8 + overlay	A351 CF8M + overlay
4	Seat	A105 + overlay	A350 LF2 + overlay	A350 LF2 + overlay	A182 F5 + overlay	A182 F5 + overlay	A182 F5 + overlay	A182 F5 + overlay	A351 CF8 + overlay	A351 CF8M + overlay
5	Stem	A182 F6a	A182 F6a	A182 F6a	A182 F6a	A182 F6a	A182 F6a	A182 F6a	A276 F304	A276 F316
6	Back Seat	A182 F6a	A182 F6a	A182 F6a	A182 F6a	A182 F6a	A182 F6a	A182 F6a	A351 CF8	A351 CF8M
7	Stuffing Box Bushing	A182 F6a	A182 F6a	A182 F6a	A182 F6a	A182 F6a	A182 F6a	A182 F6a	A182 F304	A182 F316
8	Gland Flange	A216 WCB	A352 LCC	A352 LCB	A217 WC6	A217 WC9	A217 C5	A217 C12	A351 CF8	A351 CF8M
9	Stem Nut	bronze, A439 D2								
10	Hand Wheel	cast iron								
11	Bonnet Gasket	graphite, 304 + graphite, 316 + graphite								
12	Gland Packing	graphite								
13	Eye Bolt	A193 B7	A320 L7	A320 L7	A193 B16	A193 B16	A193 B16	A193 B16	A193 B8	A193 B8M
14	Nut	A194 2H	A194 4	A194 4	A194 2H	A194 2H	A194 2H	A194 2H	A194 8	A194 8M
15	Pin	A276 410	A276 410	A276 410	A276 410	A276 410	A276 410	A276 410	304	316
16	Bonnet Bolt	A193 B7	A320 L7	A320 L7	A193 B16	A193 B16	A193 B16	A193 B16	A193 B8	A193 B8M
17	Nut	A194 2H	A194 4	A194 4	A194 2H	A194 2H	A194 2H	A194 2H	A194 8	A194 8M
18	Grease Nipple	carbon steel								
19	Threaded Bushing	carbon steel								
20	Nut	carbon steel								

GATE VALVES

TYPE C09 2

DIMENSIONS - CAST

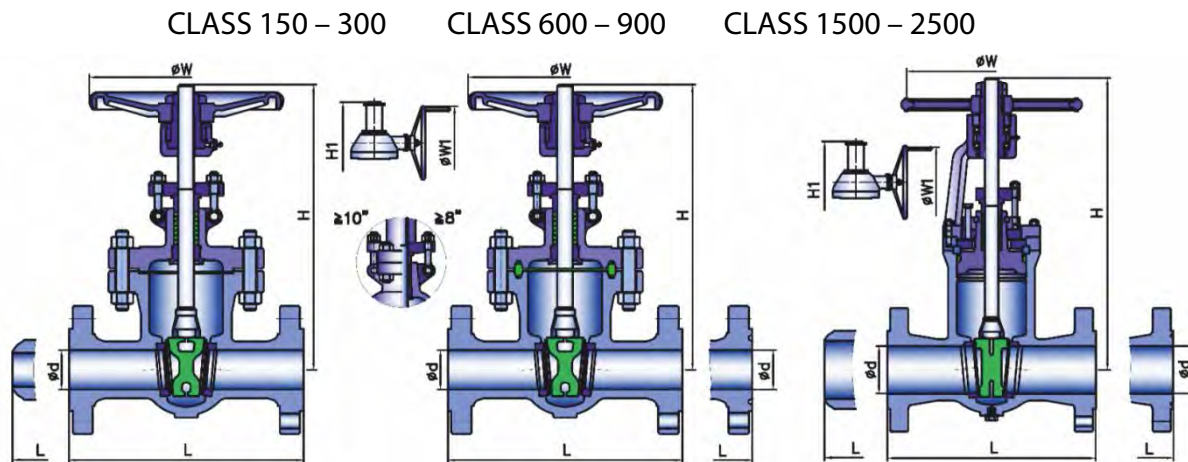

Diameter		CLASS 150									CLASS 300										
NPS	DN	L			d	H	H1	W	W1	(KG)		L			d	H	H1	W	W1	(KG)	
		1/RF	1/RTJ	2						H.W.	G.O.	1/RF	1/RTJ	2						H.W.	G.O.
2	50	178	191	216	51	400	-	200	-	19	-	216	232	216	51	420	-	200	-	26	-
2 1/2	65	191	203	241	64	435	-	200	-	27	-	241	257	241	64	446	-	200	-	31	-
3	80	203	216	283	76	515	-	250	-	34	-	283	298	283	76	537	-	250	-	49	-
4	100	229	241	305	102	595	-	280	-	49	-	305	321	305	102	619	650	280	310	74	101
5	125	254	267	381	127	725	-	280	-	63	-	381	397	381	127	722	750	300	310	99	127
6	150	267	279	403	152	780	820	300	310	78	105	403	419	403	152	806	835	350	310	131	187
8	200	292	305	419	203	975	1020	350	310	125	151	419	435	419	203	1000	1030	400	310	209	236
10	250	330	343	457	254	1150	1200	400	310	188	217	457	473	457	254	1240	1280	450	310	336	387
12	300	356	368	502	305	1380	1430	450	310	288	317	502	518	502	305	1425	1460	500	310	452	503
14	350	381	394	572	337	1545	1580	500	310	387	437	572	588	572	337	1585	1620	600	460	706	757
16	400	406	419	610	387	1733	1780	500	460	502	554	610	626	610	387	1790	1830	500	460	925	966
18	450	432	445	660	438	1915	1990	500	460	603	655	660	676	660	438	1960	2000	650	460	1133	1226
20	500	457	470	711	489	2122	2220	600	460	766	818	711	727	711	489	2158	2220	750	460	1347	1402
24	600	508	521	813	591	2520	2600	600	460	1009	1187	813	829	813	591	2576	2620	900	600	2125	2387
26	650	559	-	864	633	-	2800	-	600	-	1552	1245	1270	1245	633	-	2850	-	600	-	3002
28	700	610	-	914	684	-	3050	-	600	-	1882	1346	1372	1346	684	-	3080	-	600	-	3302
30	750	610	-	914	735	-	3130	-	600	-	2300	1397	1422	1397	735	-	3180	-	600	-	3552
32	800	660	-	965	779	-	3280	-	600	-	2552	1524	1553	1524	779	-	3300	-	600	-	4400
34	850	762	-	1016	830	-	3500	-	600	-	2952	1626	1654	1626	830	-	3550	-	600	-	5202
36	900	711	-	1016	874	-	3720	-	600	-	3390	1727	1756	1727	874	-	3760	-	600	-	6052
40	1000	813	-	1067	976	-	3800	-	600	-	3750	1955	-	1955	976	-	3920	-	600	-	6260

GATE VALVES

TYPE C09 2

DIMENSIONS - CAST

Diameter		CLASS 600										CLASS 900									
NPS	DN	L			d	H	H1	W	W1	(KG)		L			d	H	H1	W	W1	(KG)	
		1/RF	1/RTJ	2						H.W.	G.O.	1/RF	1/RTJ	2						H.W.	G.O.
2	50	292	295	292	51	444	-	200	-	33	-	368	371	368	51	500	-	280	-	71	-
2 1/2	65	330	333	330	64	500	-	250	-	53	-	419	422	419	64	550	-	280	-	111	-
3	80	356	359	356	76	558	585	280	310	61	88	381	384	381	76	610	600	300	310	141	168
4	100	432	435	432	102	665	695	300	310	108	135	457	460	457	102	702	750	350	310	200	228
5	125	508	511	508	127	760	790	350	310	176	228	559	565	559	127	850	900	400	310	259	286
6	150	559	562	559	152	868	900	450	310	217	269	610	613	610	152	980	1060	500	460	359	411
8	200	660	664	660	203	1073	1110	500	310	399	452	737	740	737	203	1100	1140	650	460	551	602
10	250	787	791	787	254	1263	1300	650	460	606	658	838	841	838	254	1320	1370	700	460	1002	1102
12	300	838	841	838	305	1600	1650	700	460	852	894	965	968	965	305	1500	1560	900	460	1217	1312
14	350	889	892	889	337	1705	1750	900	460	1179	1234	1029	1039	1029	322	1900	1955	900	600	1600	1702
16	400	991	994	991	387	1835	1900	900	460	1515	1568	1130	1140	1130	373	2050	2100	900	600	2152	2332
18	450	1092	1095	1092	438	-	2020	-	600	-	1982	1219	1232	1219	438	-	2362	-	600	-	3000
20	500	1194	1200	1194	489	-	2172	-	600	-	2462	1321	1334	1321	489	-	2463	-	600	-	3800
24	600	1397	1407	1397	591	-	2650	-	600	-	3652	-	-	-	-	-	-	-	-	-	-
28	700	1549	1562	1549	684	-	2862	-	600	-	5547	-	-	-	-	-	-	-	-	-	-
32	800	1778	1794	1778	779	-	3100	-	600	-	6800	-	-	-	-	-	-	-	-	-	-
36	900	2083	2099	2083	876	-	3450	-	600	-	8100	-	-	-	-	-	-	-	-	-	-
40	1000	2149	-	2149	976	-	3600	-	600	-	9500	-	-	-	-	-	-	-	-	-	-

Diameter		CLASS 1500										CLASS 2500									
NPS	DN	L			d	H	H1	W	W1	(KG)		L			d	H	H1	W	W1	(KG)	
		1/RF	1/RTJ	2						H.W.	G.O.	1/RF	1/RTJ	2						H.W.	G.O.
2	50	368	371	368	51	510	-	280	-	70	-	451	454	451	42	530	580	280	310	100	130
2 1/2	65	419	422	419	64	560	-	300	-	110	-	508	514	508	52	580	630	300	310	150	180
3	80	470	473	470	76	620	670	350	310	175	202	578	584	578	62	650	700	350	310	245	275
4	100	546	549	546	102	728	770	400	310	270	300	673	683	673	87	750	800	400	310	390	420
5	125	673	676	673	127	870	920	450	310	378	405	794	807	794	96	900	960	500	460	550	580
6	150	705	711	705	144	1000	1070	500	460	520	575	914	927	914	131	1040	1100	600	460	780	835
8	200	832	841	832	192	1130	1180	750	460	820	915	1022	1098	1022	179	1150	1200	750	460	1260	1355
10	250	991	1000	991	239	1360	1410	900	600	1560	1750	1270	1292	1270	223	1400	1460	900	600	2380	2565
12	300	1130	1146	1130	287	-	1620	-	600	-	2120	1422	1445	1422	265	-	1660	-	600	-	3250
14	350	1257	1276	1257	315	-	2020	-	600	-	2600	-	-	-	-	-	-	-	-	-	-
16	400	1384	1407	1384	360	-	2180	-	600	-	3450	-	-	-	-	-	-	-	-	-	-

GATE VALVES

TYPE C09 2

MATERIAL SPECIFICATION - FORGED

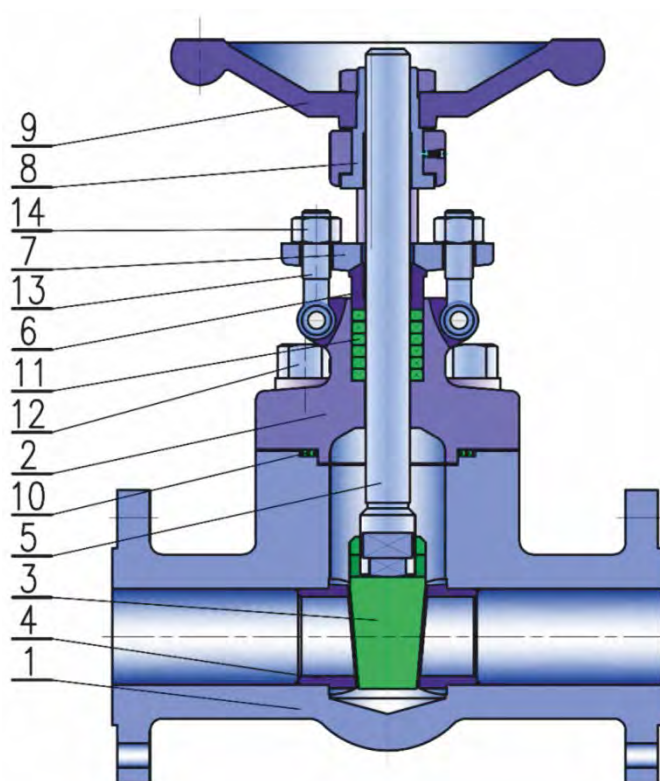

Pos.	Designation	A350 LF2	A105	A182 F5	A182 F9	A182 F304	A182 F316
1	Body	A350 LF2	A105	A182 F5	A182 F9	A182 F304	A182 F316
2	Bonnet	A350 LF2	A105	A182 F5	A182 F9	A182 F304	A182 F316
3	Wedge	A350 LF2 + overlay	A105 + overlay	A182 F5 + overlay	A182 F9 + overlay	A182 F304 + overlay	A182 F316 + overlay
4	Seat	A350 LF2 + overlay	A105 + overlay	A182 F5 + overlay	A182 F9 + overlay	A182 F304 + overlay	A182 F316 + overlay
5	Stem	A182 F6a	A182 F6a	A182 F6a	A182 F6a	A276 F304	A276 F316
6	Stuffing Box Bushing	A182 F6a	A182 F6a	A182 F6a	A182 F6a	A182 F304	A182 F316
7	Gland Flange	A350 LF2	A105	A182 F5	A182 F9	A182 F304	A182 F316
8	Stem Nut	bronze, A439 D2					
9	Hand Wheel	cast iron					
10	Bonnet Gasket	graphite, 304 + graphite, 316 + graphite					
11	Gland Packing	graphite					
12	Bonnet Bolt	A320 L7	A193 B7	A193 B16	A193 B16	A193 B8	A193 B8M
13	Eye Bolt	A320 L7	A193 B7	A193 B16	A193 B16	A193 B8	A193 B8M
14	Nut	A194 4	A194 2H	A194 2H	A194 2H	A194 8	A194 8M

GATE VALVES

TYPE C09 2

DIMENSIONS - FORGED

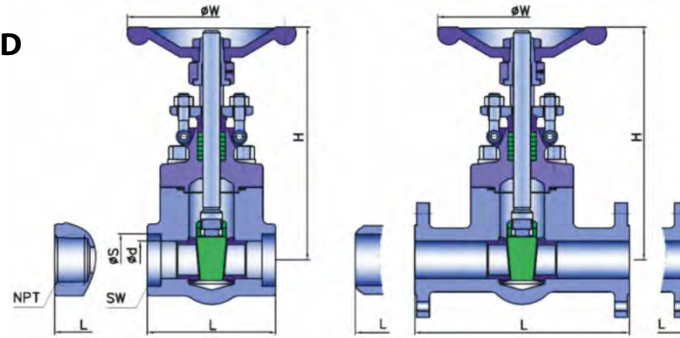

Diameter		CLASS 150										CLASS 300									
NPS	DN	L					d	S	H	W	(KG)	L					d	S	H	W	(KG)
		1/RF	1/RTJ	2	3	4						H.W.	1/RF	1/RTJ	2	3					
1/8	6	108	-	108	79	79	3,2	14,2	166	100	2,2	140	-	140	79	79	3,2	14,2	166	100	2,5
3/8	10	108	-	108	79	79	5,9	17,6	166	100	2,2	140	-	140	79	79	5,9	17,6	166	100	2,5
1/2	15	108	119	108	79	79	9,5	21,8	166	100	3	140	151	140	79	79	9,5	21,8	166	100	3,5
3/4	20	117	130	117	92	92	12,7	27,1	169	100	3,5	152	165	152	92	92	12,7	27,1	169	100	5
1	25	127	140	127	111	111	17,5	33,8	193	125	5,5	165	178	165	111	111	17,5	33,8	193	125	7
1 1/2	40	165	178	165	120	120	28,6	48,7	246	160	10,5	190	203	190	120	120	28,6	48,7	246	160	13,5
2	50	178	190	216	140	140	36,5	61,1	283	180	14,5	216	232	216	140	140	36,5	61,1	283	180	18

Diameter		CLASS 600										CLASS 800									
NPS	DN	L					d	S	H	W	(KG)	L					d	S	H	W	(KG)
		1/RF	1/RTJ	2	3	4						H.W.	1/RF	1/RTJ	2	3					
1/8	6	165	-	165	79	79	3,2	14,2	166	100	3	-	-	-	79	79	3,2	14,2	166	100	2,2
3/8	10	165	-	165	79	79	5,9	17,6	166	100	3	-	-	-	79	79	5,9	17,6	166	100	2,2
1/2	15	165	165	165	79	79	9,5	21,8	166	100	4,5	-	-	-	79	79	9,5	21,8	166	100	2,2
3/4	20	190	190	190	92	92	12,7	27,1	169	100	6	-	-	-	92	92	12,7	27,1	169	100	2,2
1	25	216	216	216	111	111	17,5	33,8	193	125	9	-	-	-	111	111	17,5	33,8	193	125	5
1 1/2	40	241	241	241	120	120	28,6	48,7	246	160	16	-	-	-	120	120	28,6	48,7	246	160	7
2	50	292	295	292	140	140	36,5	61,1	283	180	19,5	-	-	-	140	140	36,5	61,1	283	180	11

Diameter		CLASS 900,1500										CLASS 2500									
NPS	DN	L					d	S	H	W	(KG)	L					d	S	H	W	(KG)
		1/RF	1/RTJ	2	3	4						H.W.	1/RF	1/RTJ	2	3					
1/8	6	216	-	216	102	102	3,2	14,2	166	100	4	264	-	264	102	102	3,2	14,2	166	100	6
3/8	10	216	-	216	102	102	5,9	17,6	166	100	4	264	-	264	102	102	5,9	17,6	166	100	6
1/2	15	216	216	216	102	102	9,5	21,8	169	100	4	264	263	264	102	102	9,5	21,8	169	100	6
3.4	20	229	229	229	111	111	12,7	27,1	193	125	4	273	273	273	111	111	12,7	27,1	193	125	6
1	25	254	254	254	120	120	17,5	33,8	236	160	8	308	304	308	120	120	17,5	33,8	236	160	10
1 1/2	40	305	305	305	140	140	28,6	48,7	283	180	12	384	384	384	140	140	28,6	48,7	283	180	15
2	50	368	371	368	178	178	36,5	61,1	330	200	22	451	454	451	178	178	36,5	61,1	330	200	25

TYPE DESIGNATION

C09 2 C/D E M₁ Class/S

C

CONNECTION INTO PIPE

- 1 Flanged
- 2 Welded ends
- 3 Threaded
- 4 Socket welding
- 8 Combined

D

FLANGE FACING

ANSI B 16.5

- | | |
|------------|-------------------|
| PFF | Flat sealing face |
| RF | Raised face |
| LTF | Large tongue |
| STF | Small tongue |
| LGF | Large groove |
| SGF | Small groove |
| LMF | Large male |
| SMF | Small male |
| LFF | Large female |
| SFF | Small female |
| RTJ | Ring joint face |

E

CONTROL

- 1 Hand wheel
- 2 Gearbox + hand wheel
- 3 Electric actuators
- 4 Gearbox + electric actuators
- 5 Pneumatic actuators
- 9 Without control

M₁

BODY MATERIAL

- 0 Stainless steel
- 2 Cast alloy steel
- 3 Forged alloy steel
- 4 Forged carbon steel
- 5 Cast carbon steel
- LT Carbon steel for low temperatures

S

SPECIAL EXECUTION

- As** Antistatic execution
- B** With bypass





Range DN: 15 ~ 1200



Range PN: 16 ~ 160



PED 97/23/EC
PED 2014/68/EU



TR TS 10/11,
12/11, 32/11



EN 12 569
CERTIFICATE

Operating temperature: -196 °C ~ 550 °C

Connection into piping: Flanged, welded ends, threaded ends, combined execution



DESCRIPTION

S38 gate valves are controlled shut-off valves. They are designed to stop or allow the flow of the medium by external operation, either manually or via the installed drive. They are not intended to regulate the flow of the transported medium. The medium can flow in both directions. These gate valves are designed and manufactured to ensure maximum service life and reliability.

MATERIAL SPECIFICATION

S38 gate valves are made from carbon, alloyed and stainless steels. The material type can be adjusted according to the customer's request to optimally suit the operating conditions.

APPLICATION

S38 gate valves are mainly suitable for various chemicals and petrochemicals, liquids, gases and steam.

BASIC STANDARDS FOR DESIGN

Basic design

EN 1984, EN 12516 - 1

Pressure-temperature rating

EN 12 516 - 1

Testing

EN 12 266 - 1, 2

Face-to-face dimensions

EN 558, EN 12 982

Dimensions of the welded ends

EN 12 627

Top Flange dimensions

EN ISO 5210

Flange dimensions

EN 1092-1

Special

NACE MR-0175

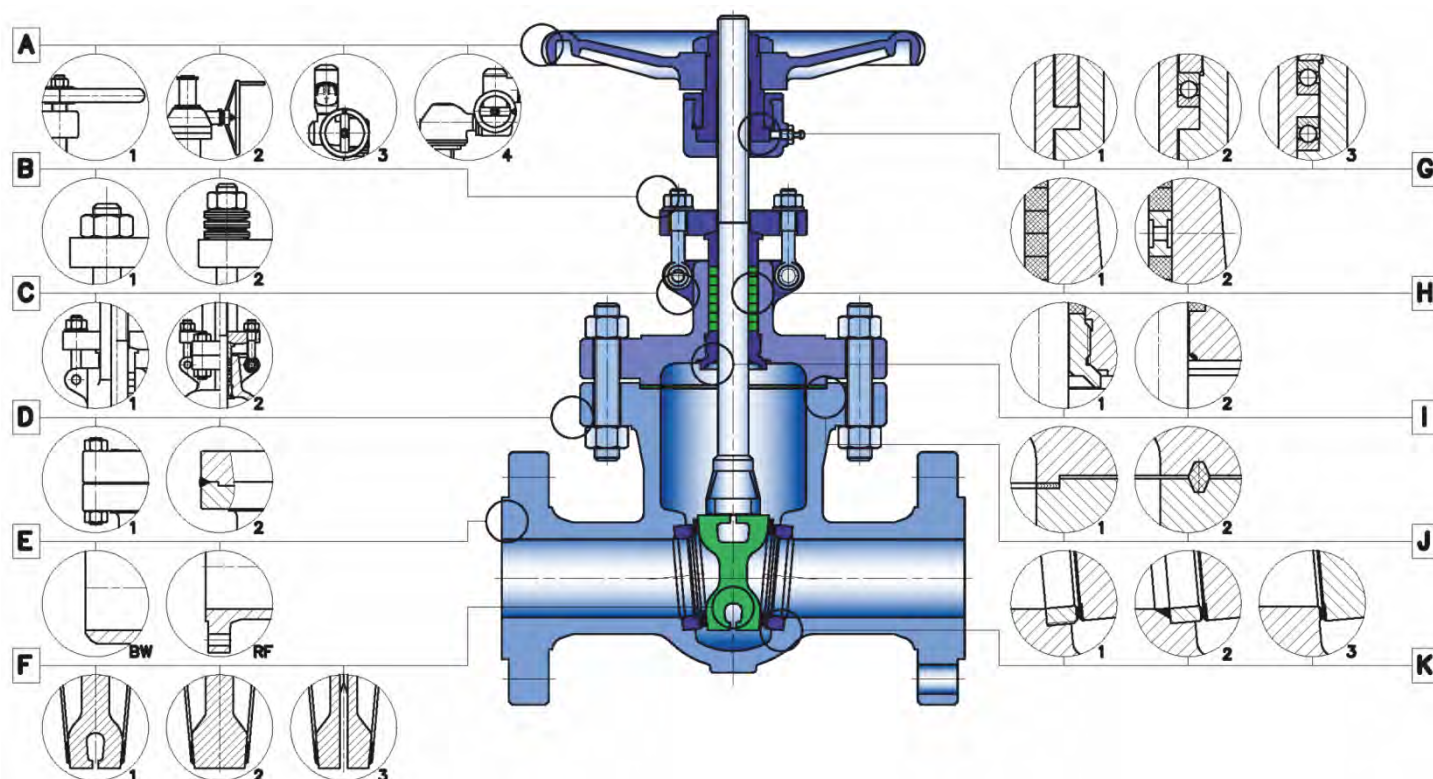
STRUCTURAL DESIGN
**A - Control**

- hand wheel
- hand wheel + gearbox
- electric actuator
- electric actuator with gearbox

B – Gland compression

- in case of valve operation with cyclic changes in pressure or at high pressures and temperatures, gland compression by means of Belleville springs, which ensure a constant pre-stress in packing, is preferred.

C — Yoke execution

- the yoke is a separate piece bolted to the bonnet
- the yoke is an integral part of the bonnet (yoke-bonnet)

D – Bonnet execution

- the bonnet is bolted to the body
- the bonnet is welded to the body

E — Connection to piping

- flanged
- welded ends
- welded ends

according to customer's requirements

F — Wedge execution

- solid
- flexible
- split wedge

G- Bedding of stem nut

- friction (sliding) type
- combination of sliding and rolling stem nut bedding
- bedding of stem nut between two axial rolling bearings

H – Execution of gland packing

- standard
- double-stem packing with lantern ring - shall be chosen in accordance with working conditions

I – Back-seat execution

- screwed into the bonnet
- integral part of the bonnet

J - Bonnet sealing

- male / female facing

K - Seats execution

- the seats are screwed into the body
- the seats are inserted into the body and welded on
- the seats are a welded layer on the body

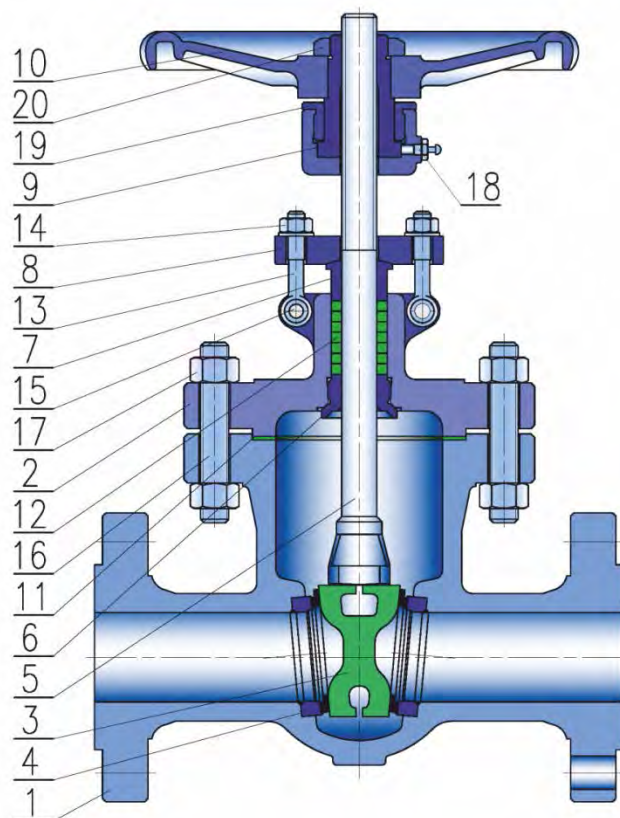
 MATERIAL SPECIFICATION - CAST

Pos.	Designation	GP 240GH (1.0619)	G17CrMo5-5 (1.7357)	GS12CrMo 19-5 (1.7363)	GX12CrMo 10-1 (1.7389)	G17Mn5 (1.1131)	G20Mn5 (1.6220)	GX5CrNi19-10 (1.4308)	GX5CrNiMo19-11-2 (1.4408)
1	Body	GP 240GH	G17CrMo5-5	GS12CrMo 19-5	GX12CrMo 10-1	G17Mn5	G20Mn5	GX5CrNi19-10	GX5CrNiMo19-11-2
2	Bonnet	GP 240GH	G17CrMo5-5	GS12CrMo 19-5	GX12CrMo 10-1	G17Mn5	G20Mn5	GX5CrNi19-10	GX5CrNiMo19-11-2
3	Wedge	GP 240GH + overlay	G17CrMo5-5 + overlay	GS12CrMo 19-5 + overlay	GX12CrMo 10-1 + overlay	G17Mn5 + overlay	G20Mn5 + overlay	GX5CrNi19-10 + overlay	GX5CrNiMo19-11-2 + overlay
4	Seat	P355NH + overlay	13CrMo4-5 + overlay	X11CrMo5 + overlay	X11CrMo 9-1 + overlay	P355NH + overlay	P355 NL1 + overlay	X5CrNi18-10 + overlay	X5CrNiMo 17-12-2 + overlay
5	Stem	X12Cr13	X12Cr13	X12Cr13	X12Cr13	X12Cr13	X12Cr13	X5CrNi18-10	X5CrNiMo 17-12-2
6	Back Seat	X12Cr13	X12Cr13	X12Cr13	X12Cr13	X12Cr13	X12Cr13	X5CrNi18-10	X5CrNiMo 17-12-2
7	Stuffing Box Bushing	P355NH	13CrMo4-5	X11CrMo5	GX12CrMo 10-1	P355NH	P355 NL1	X5CrNi18-10	X5CrNiMo 17-12-2
8	Gland Flange	GP 240GH	G17CrMo5-5	GS12CrMo 19-5	GX12CrMo 10-1	G17Mn5	G20Mn5	GX5CrNi19-10	GX5CrNiMo19-11-2
9	Stem Nut	bronze, Ad439 D2							
10	Hand Wheel	cast iron							
11	Bonnet Gasket	graphite, 304 + graphite, 316 + graphite							
12	Gland Packing	graphite							
13	Eye Bolt	25CrMo4	25CrMo4	25CrMo4	25CrMo4	25CrMo4	25CrMo4	A193 B8, A4-70	A193 B8M, A4-70
14	Nut	25CrMo4	25CrMo4	25CrMo4	25CrMo4	25CrMo4	25CrMo4	A194 8, A4 - 70	A194 8M, A4-70
15	Pin	X12Cr13	X12Cr13	X12Cr13	X12Cr13	X12Cr13	X12Cr13	X12Cr13	X12Cr13
16	Bonnet Bolt	42CrMo4	A193 B16	A193 B16	A193 B16	42CrMo4	26CrMo4	A193 B8, A4-70	A193 B8M, A4-70
17	Nut	25CrMo4	A194 7	A194 7	A194 7	25CrMo4	26CrMo4	A194 8, A4 - 70	A194 8M, A4 - 70
18	Grease Nipple	carbon steel							
19	Threaded Bushing	carbon steel							
20	Nut	carbon steel							

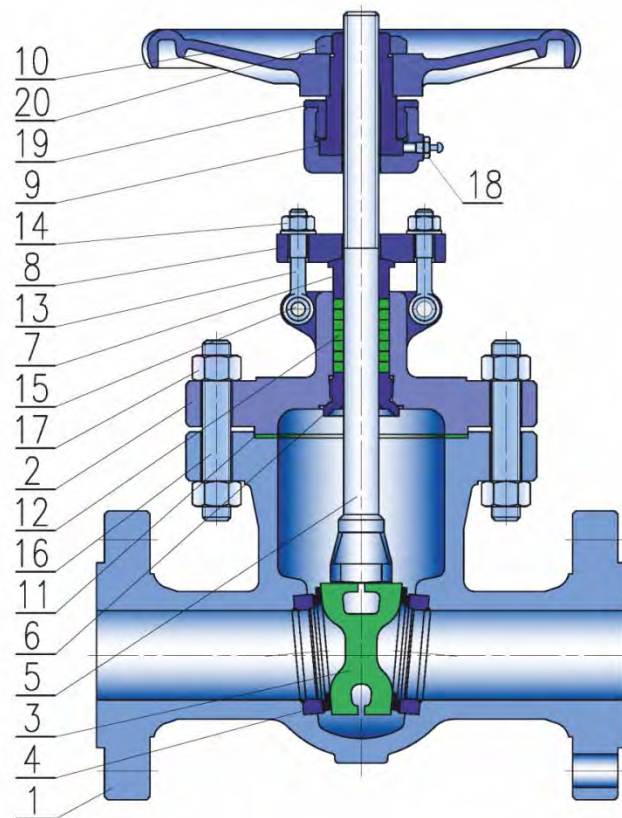
 MATERIAL SPECIFICATION - CAST

Pos.	Designation	WCB	LCC	LCB	WC6	WC9	C5	C12	CF8 / 304	CF8M / 316
1	Body	A216 WCB	A352 LCC	A352 LCB	A217 WC6	A217 WC9	A217 C5	A217 C12	A351 CF8	A351 CF8M
2	Bonnet	A216 WCB	A352 LCC	A352 LCB	A217 WC6	A217 WC9	A217 C5	A217 C12	A351 CF8	A351 CF8M
3	Wedge	A216 WCB + overlay	A352 LCC + overlay	A352 LCB + overlay	A217 WC6 + overlay	A217 WC9 + overlay	A217 C5 + overlay	A217 C12 + overlay	A351 CF8 + overlay	A351 CF8M + overlay
4	Seat	A105 + overlay	A350 LF2 + overlay	A350 LF2 + overlay	A182 F5 + overlay	A182 F5 + overlay	A182 F5 + overlay	A182 F5 + overlay	A351 CF8 + overlay	A351 CF8M + overlay
5	Stem	A182 F6a	A182 F6a	A182 F6a	A182 F6a	A182 F6a	A182 F6a	A182 F6a	A276 F304	A276 F316
6	Back Seat	A182 F6a	A182 F6a	A182 F6a	A182 F6a	A182 F6a	A182 F6a	A182 F6a	A351 CF8	A351 CF8M
7	Stuffing Box Bushing	A182 F6a	A182 F6a	A182 F6a	A182 F6a	A182 F6a	A182 F6a	A182 F6a	A182 F304	A182 F316
8	Gland Flange	A216 WCB	A352 LCC	A352 LCB	A217 WC6	A217 WC9	A217 C5	A217 C12	A351 CF8	A351 CF8M
9	Stem Nut	bronze, A439 D2								
10	Hand Wheel	cast iron								
11	Bonnet Gasket	graphite, 304 + graphite, 316 + graphite								
12	Gland Packing	graphite								
13	Eye Bolt	A193 B7	A320 L7	A320 L7	A193 B16	A193 B16	A193 B16	A193 B16	A193 B8	A193 B8M
14	Nut	A194 2H	A194 4	A194 4	A194 2H	A194 2H	A194 2H	A194 2H	A194 8	A194 8M
15	Pin	A276 410	A276 410	A276 410	A276 410	A276 410	A276 410	A276 410	304	316
16	Bonnet Bolt	A193 B7	A320 L7	A320 L7	A193 B16	A193 B16	A193 B16	A193 B16	A193 B8	A193 B8M
17	Nut	A194 2H	A194 4	A194 4	A194 2H	A194 2H	A194 2H	A194 2H	A194 8	A194 8M
18	Grease Nipple	carbon steel								
19	Threaded Bushing	carbon steel								
20	Nut	carbon steel								

GATE VALVES

TYPE S38

MATERIAL SPECIFICATION - FORGED

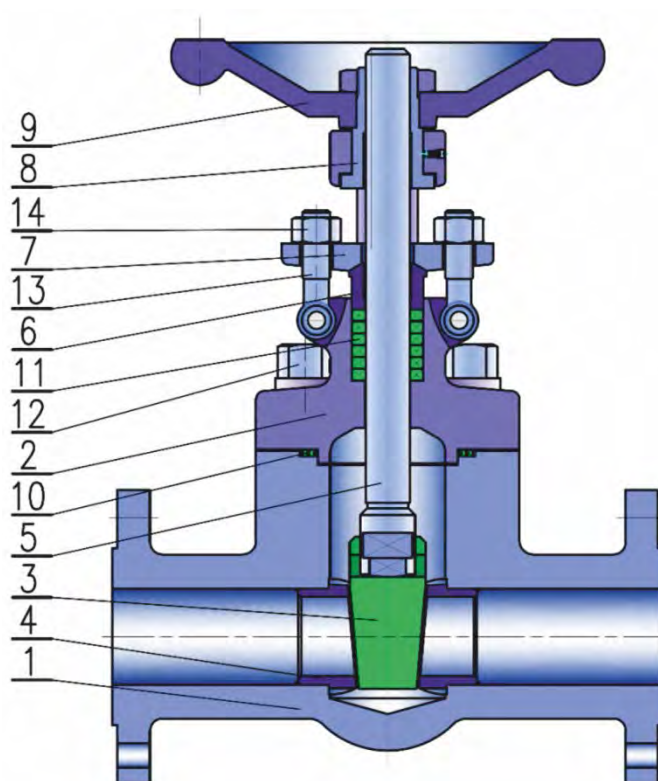

Pos.	Designation	A350 LF2	A105	A182 F5	A182 F9	A182 F304	A182 F316
1	Body	A350 LF2	A105	A182 F5	A182 F9	A182 F304	A182 F316
2	Bonnet	A350 LF2	A105	A182 F5	A182 F9	A182 F304	A182 F316
3	Wedge	A350 LF2 + overlay	A105 + overlay	A182 F5 + overlay	A182 F9 + overlay	A182 F304 + overlay	A182 F316 + overlay
4	Seat	A350 LF2 + overlay	A105 + overlay	A182 F5 + overlay	A182 F9 + overlay	A182 F304 + overlay	A182 F316 + overlay
5	Stem	A182 F6a	A182 F6a	A182 F6a	A182 F6a	A276 F304	A276 F316
6	Stuffing Box Bushing	A182 F6a	A182 F6a	A182 F6a	A182 F6a	A182 F304	A182 F316
7	Gland Flange	A350 LF2	A105	A182 F5	A182 F9	A182 F304	A182 F316
8	Stem Nut	bronze, A439 D2					
9	Hand Wheel	cast iron					
10	Bonnet Gasket	graphite, 304 + graphite, 316 + graphite					
11	Gland Packing	graphite					
12	Bonnet Bolt	A320 L7	A193 B7	A193 B16	A193 B16	A193 B8	A193 B8M
13	Eye Bolt	A320 L7	A193 B7	A193 B16	A193 B16	A193 B8	A193 B8M
14	Nut	A194 4	A194 2H	A194 2H	A194 2H	A194 8	A194 8M

GATE VALVES

TYPE S38

DIMENSIONS - CAST

DN	PN 16									PN 25								
	L		d	H	H1	W	W1	(KG)		L		d	H	H1	W	W1	(KG)	
	1	2						H.W.	G.O.	1	2						H.W.	G.O.
15	130	130	14,0	170	-	120	-	5	-	130	130	14,0	170	-	120	-	5,5	-
20	150	150	19,0	190	-	140	-	6,5	-	150	150	19,0	190	-	140	-	7	-
25	160	160	25,0	205	-	160	-	9	-	160	160	25,0	205	-	160	-	11	-
32	180	180	32,0	270	-	180	-	12	-	180	180	32,0	270	-	180	-	14	-
40	240	240	43,1	310	-	200	-	26,5	-	240	240	43,1	310	-	200	-	20	-
50	250	250	54,5	358	-	240	-	29	-	250	250	54,5	358	-	240	-	34	-
65	270	270	70,3	373	-	240	-	33	-	270	270	70,3	373	-	240	-	36	-
80	280	280	82,5	435	-	280	-	46	-	280	280	82,5	435	-	280	-	50	-
100	300	300	107,1	500	-	320	-	63	-	300	300	107,1	500	-	320	-	69	-
125	325	325	131,7	614	-	360	-	108	-	325	325	131,7	614	-	360	-	116	-
150	350	350	159,3	674	994	360	310	134	199	350	350	161,5	674	994	360	310	141	206
200	400	400	206,5	818	1138	400	310	192	254	400	400	206,5	818	1138	400	310	192	257
250	450	450	260,4	969	1409	450	310	273	310	450	450	258,2	969	1409	450	310	207	317
300	500	500	309,7	1145	1588	560	310	379	391	500	500	307,9	1145	1588	560	310	400	412
350	550	550	339,6	1280	1755	640	310	590	729	550	550	337,6	1280	1750	640	310	631	750
400	600	600	390,0	1450	1902	640	460	849	992	600	600	388,8	1450	1902	640	460	900	1042
450	650	650	438,0	1563	2141	720	460	907	1168	650	650	438,0	1563	2141	720	460	1013	1274
500	700	700	492,0	1676	2276	720	460	958	1222	700	700	488,0	1676	2276	720	460	1166	1420
600	800	800	591,0	1810	2474	800	460	1112	1376	800	800	591,0	1810	2474	800	460	1258	1522
700	900	900	684,0	-	3046	-	600	-	-	900	900	684,0	-	3046	-	600	-	-
800	1000	1000	779,0	-	3250	-	600	-	-	1000	1000	779,0	-	6250	-	600	-	-
900	1100	1100	874,0	-	3509	-	600	-	-	1100	1100	874,0	-	3509	-	600	-	-

GATE VALVES

TYPE S38

DIMENSIONS - CAST

DN	PN 40									PN 63								
	L		d	H	H1	W	W1	(KG)		L		d	H	H1	W	W1	(KG)	
	1	2						H.W.	G.O.	1	2						H.W.	G.O.
15	130	130	14,0	135	-	120	-	6	-	170	170	14,0	140	-	100	-	7	-
20	150	150	19,0	190	-	140	-	8	-	190	190	19,0	140	-	100	-	9	-
25	160	160	25,0	205	-	160	-	12	-	210	210	25,0	215	-	180	-	12	-
32	180	180	32,0	270	-	180	-	15	-	230	230	32,0	270	-	180	-	16	-
40	240	240	43,1	310	-	200	-	31	-	240	240	42,5	345	-	200	-	32	-
50	250	250	54,5	371	-	280	-	34	-	250	250	53,5	371	-	280	-	39	-
65	290	290	70,3	393	-	280	-	38	-	290	290	69,7	393	-	280	-	43	-
80	310	310	82,5	455	-	320	-	51	-	310	310	81,7	455	-	320	-	60	-
100	350	350	107,1	551	871	360	310	81	163	350	350	106,3	551	1020	360	310	89	154
125	400	400	131,7	634	948	400	310	128	190	400	400	130,7	638	1100	400	310	140	205
150	450	450	161,5	708	1028	400	310	155	219	450	450	158,3	718	1290	450	310	207	317
200	550	550	206,3	858	1325	450	310	265	373	550	550	204,9	873	1475	560	310	327	437
250	650	650	258,2	1015	1400	560	310	370	480	650	650	255,2	1050	1500	640	310	467	606
300	750	750	307,9	1201	1653	640	310	550	686	750	750	301,9	1215	1820	640	310	590	732
350	850	850	337,9	1308	1791	640	460	679	821	850	850	337,0	-	2216	-	460	-	1110
400	950	950	384,4	1483	2092	720	460	953	1214	950	950	387,0	-	2838	-	460	-	1540
500	1150	1150	479,6	-	2465	-	460	-	2150	1150	1150	489,0	-	3320	-	460	-	2460

DN	PN 100									PN 160								
	L		d	H	H1	W	W1	(KG)		L		d	H	H1	W	W1	(KG)	
	1	2						H.W.	G.O.	1	2						H.W.	G.O.
15	170	170	14,0	140	-	200	-	6	-	170	170	14,0	230	-	200	-	7	-
20	190	190	19,0	140	-	200	-	11	-	190	190	19,0	260	-	200	-	10	-
25	210	210	25,0	310	-	280	-	13	-	210	210	25,0	280	-	280	-	14	-
32	230	230	32,0	320	-	320	-	20	-	230	230	32,0	312	-	320	-	21	-
40	240	240	42,5	360	-	320	-	30	-	260	260	42,5	350	-	320	-	26	-
50	250	250	53,9	371	-	360	-	50	-	300	300	51,0	512	-	360	-	73	-
65	290	290	68,9	393	-	400	-	70	-	340	340	64,0	560	-	360	-	110	-
80	310	310	80,9	455	892	400	310	100	165	390	390	76,0	585	905	400	310	141	206
100	350	350	104,3	551	1013	400	310	110	220	450	450	102,0	631	1071	450	310	185	295
125	400	400	127,1	638	1184	560	310	186	292	525	525	127,0	723	1163	560	310	320	432
150	450	450	154,1	718	1250	560	310	250	389	600	600	152,0	820	1170	640	460	462	601
200	550	550	199,1	873	1250	560	310	360	502	750	750	203,0	990	1440	720	460	711	853
250	650	650	248,0	1050	1650	640	460	485	790	-	-	-	-	-	-	-	-	-
300	750	750	295,5	1215	1800	640	460	633	910	-	-	-	-	-	-	-	-	-
350	850	850	337,0	-	2030	-	460	-	1610	-	-	-	-	-	-	-	-	-
400	950	950	387,0	-	2250	-	460	-	2512	-	-	-	-	-	-	-	-	-

 TYPE DESIGNATION
S38 C/D E M₁ PN/S**C****CONNECTION INTO PIPE**

- 1 Flanged
- 2 Welded ends
- 8 Combined

M₁**BODY MATERIAL**

- 0 Stainless steel
- 2 Cast alloy steel
- 3 Forged alloy steel
- 4 Forged carbon steel
- 5 Cast carbon steel
- LT Carbon steel for low temperatures

D**FLANGE FACING****EN 1092 - 1**

- A Flat face
- B Raised face
- C Tongue face
- D Groove face
- E Spigot
- F Recess
- G O - ring recess
- H O - ring groove

E**CONTROL**

- 1 Hand wheel
- 2 Gearbox + hand wheel
- 3 Electric actuators
- 4 Gearbox + electric actuators
- 9 Without control

S**SPECIAL EXECUTION**

- As Antistatic execution
- B Bypass





Range DN: 50 ~ 400



PED 97/23/EC
PED 2014/68/EU



TR TS 10/11,
32/11



Range PN: 160 ~ 400



**HIGH-PRESSURE
EXECUTION**

Operating temperature: -196 °C ~ 550 °C

Connection into piping: Flanged, welded ends, combined execution

DESCRIPTION

S43 gate valves (high-pressure execution) are controlled shut-off valves. They are designed to stop or allow the flow of the medium by external operation, either manually or via the installed drive. The medium can flow in both directions. These gate valves are designed and manufactured to ensure maximum service life and reliability.

MATERIAL SPECIFICATION

S43 gate valves are made from carbon, alloy and stainless steels. The material type can be adjusted according to the customer's request to optimally suit the operating conditions.

APPLICATION

S43 gate valves are suitable for various liquids, gases and steam. They are specially designed for use in the power engineering and chemical industry.

BASIC STANDARDS FOR DESIGN

Basic design

EN 1984, EN 12516 - 1

Pressure-temperature rating

EN 12 516 - 1

Testing

EN 12 266 - 1, 2

Face-to-face dimensions

EN 558, EN 12 982

Dimensions of the welded ends

EN 12 627

Top Flange dimensions

EN ISO 5210

Flange dimensions

EN 1092-1

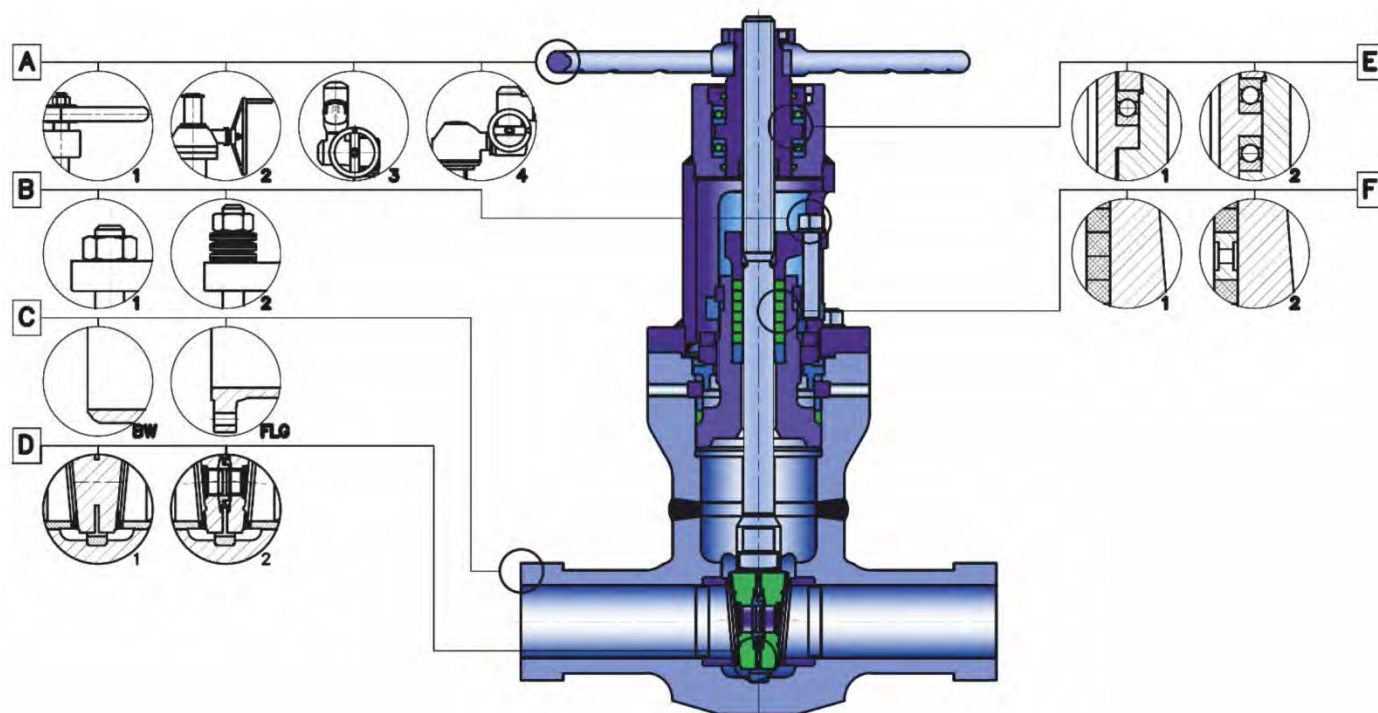
 STRUCTURAL DESIGN
**A - Control**

- hand wheel
- hand wheel+gearbox
- electric actuator
- electric actuator with gearbox

B – Gland compression

- in case of valve operation with cyclic changes in pressure or at high pressures and temperatures, the gland compression by means of Belleville springs, which secure a constant pre-stress in packing, is preferred

C — Connection into piping

- flanged
- with welding-ends
- according to customer's requirements

D – Wedge execution

- flexible
- split wedge

E- Bedding of stem nut

- combination of sliding and rolling stem nut bedding
- bedding of stem nut between two axial rolling bearings

F — Execution of gland packing

- standard
- double stem packing with lantern ring-shall be chosen in dependence on working conditions

GATE VALVES

TYPE S43

MATERIAL SPECIFICATION

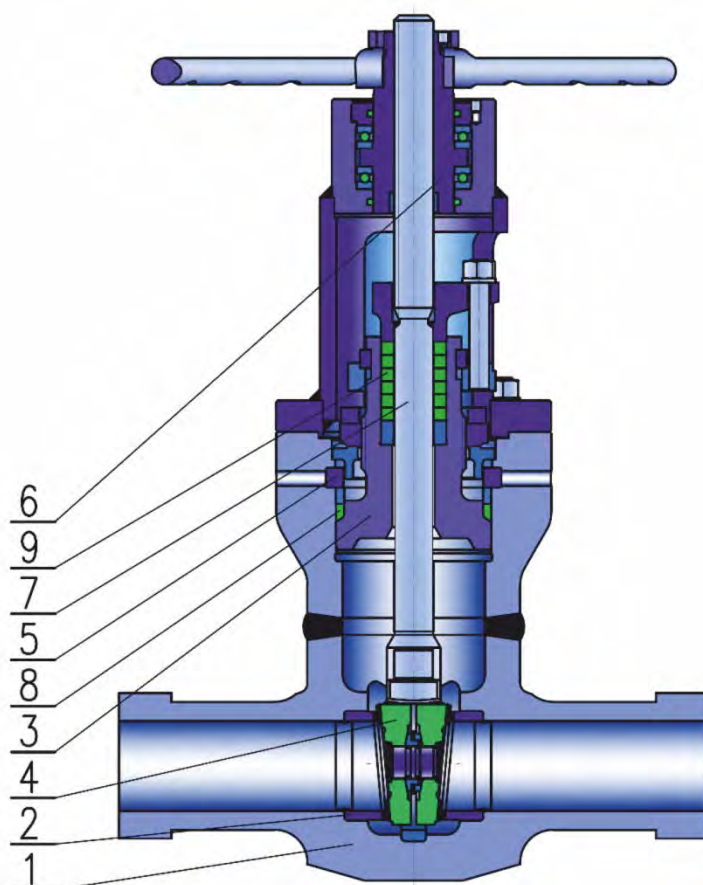

Pos.	Designation	P250GH (1.0460)	P265GH (1.0460)	P285NH (1.0477)	16Mo3 (1.5415)	G20Mo5 (1.5419)	13CrMo4-5 (1.7335)	14MoV6-3 (1.7715)	10CrMo9-10 (1.7380)	X20CrMoV12-1 (1.4922)	X10CrMoVNb9-1 (1.4903)	X6CrNiTi18-10 (1.4541)
1	Body	P250GH(1.0460)	P265GH(1.0425)	P285NH (1.0477)	16Mo3 (1.5415)	G20Mo5 (1.5419)	13CrMo4-5 (1.7335)	14MoV6-3 (1.7715)	10CrMo9-10 (1.7380)	X20CrMoV12-1 (1.4922)	X10CrMoVNb9-1 (1.4903)	X6CrNiTi18-10 (1.4541)
2	Bonnet	P250GH(1.0460) + overlay	P265GH(1.0425)+ overlay	P285NH(1.0477)+ overlay	16Mo3 (1.5415)+ overlay	G20Mo5 (1.5419)+ overlay	13CrMo4-5 (1.7335)+ overlay	14MoV6-3 (1.7715)+ overlay	10CrMo9-10 (1.7380)+ overlay	X20CrMoV12-1 (1.4922)+ overlay	X10CrMoVNb9-1 (1.4903)+ overlay	X6CrNiTi18-10 (1.4541)+ overlay
3	Pressure Sealing	P250GH(1.046)	P265GH(1.0425)	P285NH (1.0477)	16Mo3 (1.5415)	G20Mo5 (1.5419)	13CrMo4-5 (1.7335)	14MoV6-3 (1.7715)	10CrMo9-10 (1.7380)	X20CrMoV12-1 (1.4922)	X10CrMoVNb9-1 (1.4903)	X6CrNiTi18-10 (1.4541)
4	Wedge	P250GH(1.0460) + overlay	P265GH(1.0425)+ overlay	P285NH(1.0477)+ overlay	16Mo3 (1.5415)+ overlay	G20Mo5 (1.5419)+ overlay	13CrMo4-5 (1.7335)+ overlay	14MoV6-3 (1.7715)+ overlay	10CrMo9-10 (1.7380)+ overlay	X20CrMoV12-1 (1.4922)+ overlay	X10CrMoVNb9-1 (1.4903)+ overlay	X6CrNiTi18-10 (1.4541)+ overlay
5	Split Ring	P250GH(1.0460)	P265GH(1.0425)	P285NH (1.0477)	16Mo3 (1.5415)	G20Mo5 (1.5419)	13CrMo4-5 (1.7335)	14MoV6-3 (1.7715)	10CrMo9-10 (1.7380)	X20CrMoV12-1 (1.4922)	X10CrMoVNb9-1 (1.4903)	X6CrNiTi18-10 (1.4541)
6	Stem Nut	bronze										
7	Stem	X22CrMoV12-1 (1.4923)										
8	Gasket	graphite										
9	Gland Packing	graphite										

GATE VALVES

TYPE S43

DIMENSIONS

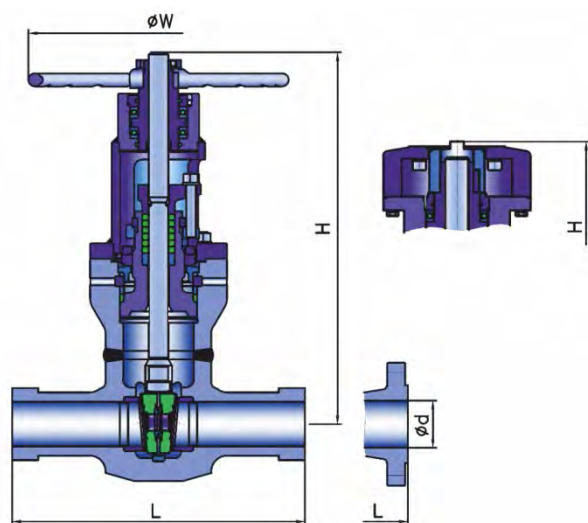

DN	PN 160						PN 250					
	L		d	H	W	(KG)	L		d	H	W	(KG)
	1	2					1	2				
50/40	270	270	40	460	320	51	310	310	40	460	320	55
50/50	300	300	50	481	320	55	350	350	50	481	320	58
65/50	360	360	50	481	320	63	425	425	50	481	320	71
80/75	390	390	75	619	400	108	470	470	75	619	400	120
100/75	450	450	75	619	400	110	550	550	75	619	400	142
125/110	525	525	110	803	500	262	650	650	110	803	500	298
150/110	600	600	110	803	500	283	750	750	110	803	500	301
200/150	750	750	150	951	630	519	950	950	150	951	630	644
250/200	900	900	200	1199	710	1017	1150	1150	200	1199	710	1218
300/250	1050	1050	250	1344	800	3443	-	-	-	-	-	-

DN	PN 320					PN 400				
	L	d	H	W	(KG)	L	d	H	W	(KG)
50/40	320	40	452	320	81	320	40	452	320	87
50/50	360	50	458	320	90	360	50	458	320	98
65/50	360	50	458	320	96	360	50	458	320	105
65/55	360	55	458	320	95	360	55	458	320	104
80/75	450	75	666	400	206	450	75	666	400	220
100/75	450	75	666	400	202	450	75	666	400	217
125/110	500	110	746	500	255	500	110	746	500	269
150/110	550	110	746	500	258	550	110	746	500	274
175/125	650	125	950	630	552	650	125	950	630	588
175/150	650	150	1083	630	841	650	150	1083	630	873
200/150	650	150	1083	710	850	650	150	1083	710	882
225/175	700	175	1332	710	1603	700	175	1332	710	1724
250/200	800	200	1450	710	2020	800	200	1450	710	2145
275/200	850	200	1450	710	2034	850	200	1450	710	2160
250/225	800	225	1600	710	2705	800	225	1600	710	2904
275/225	850	225	1600	800	2717	850	225	1600	800	2925
300/225	900	225	1600	800	2730	900	225	1600	800	2946
300/250	1000	250	1694	-	3152	1000	250	1694	-	3498
350/275	1000	275	1850	-	4426	1000	275	1850	-	4761
400/275	1000	275	1850	-	4460	1000	275	1850	-	4795

 TYPE DESIGNATION

S43 C E M₁ PN DN/Ø d/S
C**CONNECTION INTO PIPE**

- 1 Flanged
- 2 Welded ends
- 8 Combined

M₁**BODY MATERIAL**

- 0 Stainless steel
 - 3 Forged alloy steel
 - 4 Forged carbon steel
- L**
T Carbon steel for low temperatures

D**FLANGE FACING****EN 1092 - 1**

- A** Flat face
- B** Raised face
- C** Tongue face
- D** Groove face
- E** Spigot
- F** Recess
- G** O - ring recess
- H** O - ring groove

E**CONTROL**

- 1 Hand wheel
- 2 Gearbox + hand wheel
- 3 Electric actuators
- 4 Gearbox + electric actuators
- 5 Pneumatic actuators
- 9 Without control

S**SPECIAL EXECUTION**

- As** Antistatic execution





Range DN: 15 ~ 1200
NPS: 1 1/2" ~ 40"



PED 97/23/EC
PED 2014/68/EU



TR TS 10/11,
12/11, 32/11



Range PN: 16 ~ 160
Class: 150 - 900

Operating temperature: -196 °C ~ 550 °C

Connection into piping: Flanged, welded ends, combined execution



DESCRIPTION

S38/S through conduit gate valves are controlled shut-off valves. They are designed to stop or allow the flow of the medium by external operation, either manually or via the installed drive. They are not intended to regulate the flow of the transported medium. The medium can flow in both directions. These gate valves are designed and manufactured to ensure maximum service life and reliability.

MATERIAL SPECIFICATION

S38/S through conduit gate valves are made from carbon, alloy and stainless steels. The material type can be adjusted according to the customer's request to optimally suit the operating conditions.

APPLICATION

S38/S through conduit gate valves are suitable for various liquids, gases and steam.

BASIC STANDARDS FOR DESIGN

Basic design

API 6D, ASME B16.34

Pressure-temperature rating

ASME B16.34, EN 12 516 - 1

Testing

API 598 EN 12 266 - 1, 2

Face-to-face dimensions

ANSI B16.10, EN 558, EN 12 982

Dimensions of the welded ends

ANSI B16.25, EN 12 627

Top Flange dimensions

EN ISO 5210

Flange dimensions

ANSI B 16.5, ANSI B16.47A, EN1092 - 1

Special

NACE MR-0175

THROUGH CONDUIT GATE VALVES

TYPE S38/S

STRUCTURAL DESIGN

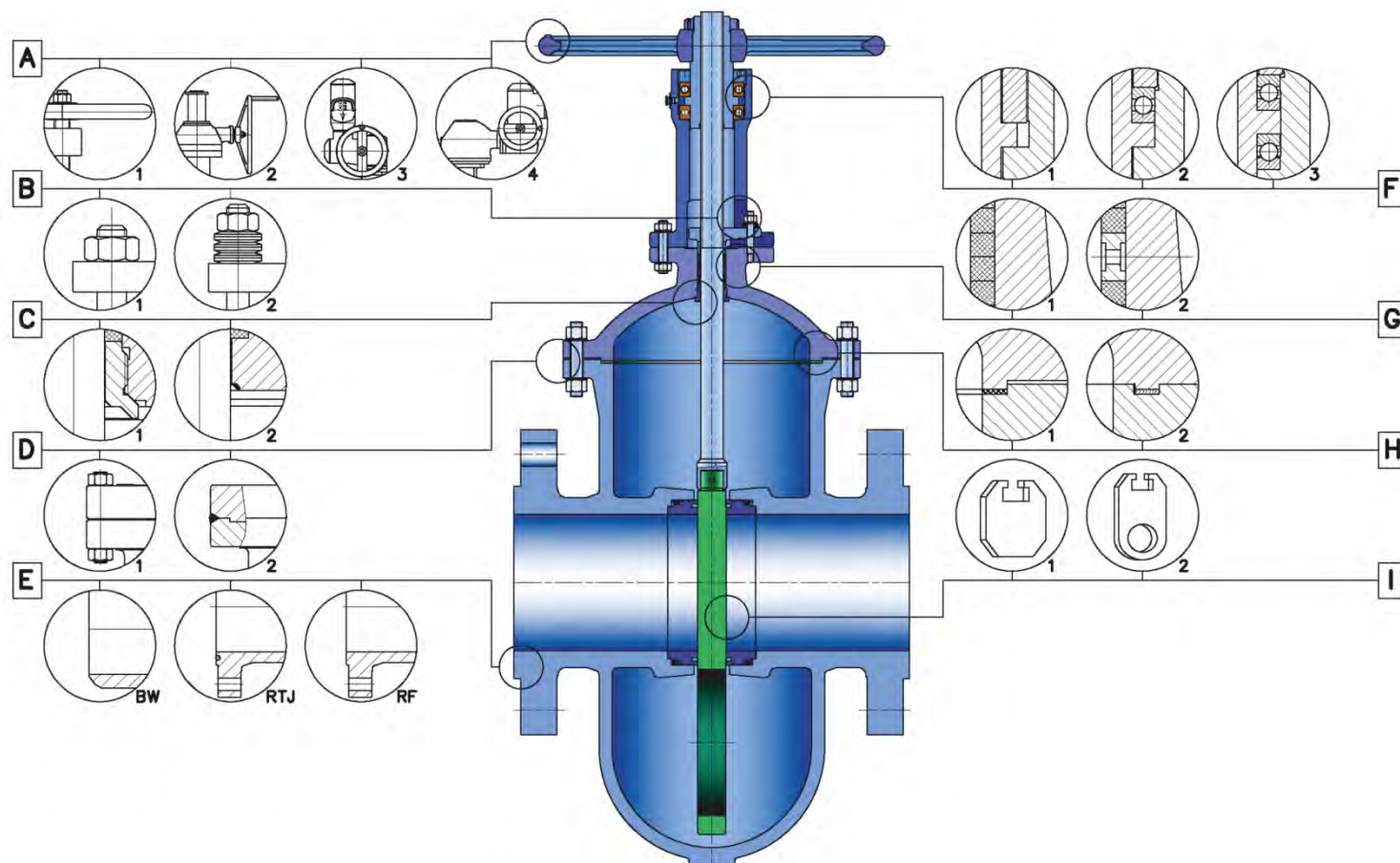

A – Control

- hand wheel
- hand wheel + gearbox
- electric actuator
- electric actuator with gearbox

B – Gland compression

- in case of valve operation with cyclic changes in pressure or at high pressures and temperatures, gland compression by means of Belleville springs, which ensure a constant pre-stress in packing, is preferred.

C - Back seat execution

- screwed into the bonnet
- integral part of the bonnet

D - Bonnet execution

- the bonnet is bolted to the body
- the bonnet is welded to the body

E - Connection to piping

- flanged
- with rough or smooth raised face
- with male / female facing
- with tongue / groove facing
- with RTJ
- welded
- with welded ends according to customer's requirements

F - Bedding of stem nut

- depending on the operating torque
- friction (sliding) type
- combination of sliding and rolling stem nut bedding
- bedding of stem nut between two axial rolling bearings

G - Execution of gland packing

- standard
- double stem packing with lantern ring - shall be chosen in accordance with working conditions

H - Bonnet sealing

- CLASS 150 to CLASS 400 – by gasket for male-female body/bonnet connection
- CLASS 600, 900 – by spiral wound gasket for tongue-groove body/bonnet connection

I – Disk execution

- The disk can be either with or without a hole. When using a disk with a hole, the pressure loss of the valve is the same as the pressure loss of the pipeline of the same inside diameter and length. The pressure loss of the valve with a disk without a hole is smaller than the pressure loss of the wedge gate valve. The flow coefficients of both discs are nearly identical except for the above-mentioned pressure loss.

THROUGH CONDUIT GATE VALVES

TYPE S38/S

MATERIAL SPECIFICATION

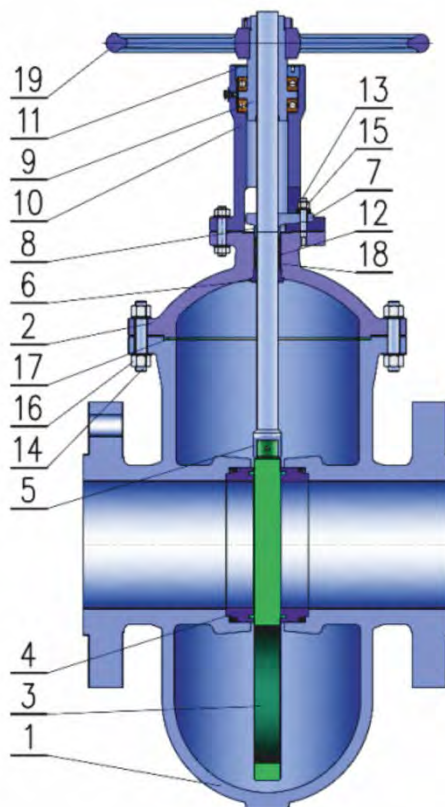

Pos.	Designation	WCB	LCC	LCB	WC 6	WC 9	C 5	C 12	CF8 / 304	CF8M / 316
1	Body	A216 WCB	A352 LCC	A352 LCB	A217 WC6	A217 WC9	A217 C5	A217 C12	A351 CF8	A351 CF8M
2	Bonnet	A216 WCB	A352 LCC	A352 LCB	A217 WC6	A217 WC9	A217 C5	A217 C12	A351 CF8	A351 CF8M
3	Disk	A105 + overlay	A350 LF3 + overlay	A350 LF3 + overlay	A217 WC6 + overlay	A217 WC9 + overlay	A217 C5 + overlay	A217 C12 + overlay	A182 F304	A182 F316
4	Seat	A105 + overlay	A350 LF3 + overlay	A350 LF3 + overlay	A182 F5 + overlay				A182 F304	A182 F316
5	Stem	A276 - 410	A182 F6a						A182 F304	A182 F316
6	Back seat	A182 F6a						A351 CF8	A351 CF8M	
7	Gland flange	A216 WCB	A352 LCC	A352 LCB	A217 WC6	A217 WC9	A217 C5	A217 C12	A351 CF8	A351 CF8M
8	Stuffing box bushing	A182 F6a						A182 F304	A182 F316	
9	Stem nut	bronze, A439 D2								
10	Yoke	A216 WCB	A352 LCC	A352 LCB	A217 WC6	A217 WC9	A217 C5	A217 C12	A351 CF8	A351 CF8M
11	Threaded bushing	carbon steel							stainless steel	stainless steel
12	Lantern ring	A276 - 420	A182 F6a						A182 F304	A182 F316
13	Bolt of gland flange	A193 B7	A320 L7	A320 L7	A193 B16	A193 B16	A193 B16	A193 B16	A193 B8	A193 B8M
14	Bolt	A193 B7	A320 L7	A320 L7	A193 B16	A193 B16	A193 B16	A193 B16	A193 B8	A193 B8M
15	Nut	A194 2H	A194 4	A194 4	A194 2H	A194 2H	A194 2H	A194 2H	A194 8	A194 8M
16	Nut	A194 2H	A194 4	A194 4	A194 2H	A194 2H	A194 2H	A194 2H	A194 8	A194 8M
17	Gasket	304 + graphite								316L + graphite
18	Stem packing	graphite								
19	Hand wheel	cast iron								

THROUGH CONDUIT GATE VALVES

TYPE S38/S

MATERIAL SPECIFICATION

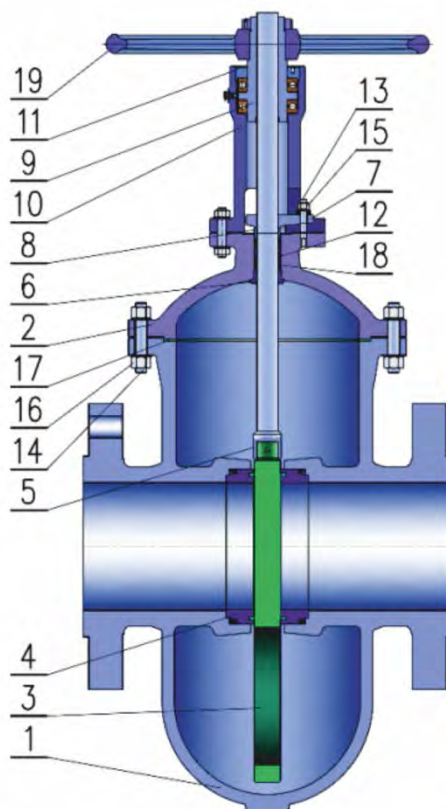

Pos.	Designation	Material								
1	Body	GP 240GH	G17CrMo5-5	GS12CrMo 19-5	GX12CrMo 10-1	G17Mn5	G20Mn5	GX5CrNi19-10	GX5CrNiMo19-11-2	
2	Bonnet	GP 240GH	G17CrMo5-5	GS12CrMo 19-5	GX12CrMo 10-1	G17Mn5	G20Mn5	GX5CrNi19-10	GX5CrNiMo19-11-2	
3	Disk	GP 240GH + overlay	G17CrMo5-5 + overlay	GS12CrMo 19-5 + overlay	GX12CrMo 10-1 + overlay	G17Mn5 + overlay	G20Mn5 + overlay	GX5CrNi19-10 + overlay	GX5CrNiMo19-11-2 + overlay	
4	Seat	P355NH + overlay	13CrMo4-5 + overlay	X11CrMo5 + overlay	X11CrMo 9-1 + overlay	P355NH + overlay	P355 NL1 + overlay	X5CrNi18-10 + overlay	X5CrNiMo 17-12-2 + overlay	
5	Stem	X12Cr13							X5CrNi18-10	X5CrNiMo 17-12-2
6	Back seat	X12Cr13							X5CrNi18-10	X5CrNiMo 17-12-2
7	Gland flange	GP 240GH	G17CrMo5-5	GS12CrMo 19-5	GX12CrMo 10-1	G17Mn5	G20Mn5	GX5CrNi19-10	GX5CrNiMo19-11-2	
8	Stuffing box bushing	P355NH	13CrMo4-5	X11CrMo5	GX12CrMo 10-1	P355NH	P355NL1	X5CrNi18-10	X5CrNiMo 17-12-2	
9	Stem nut	Bronze ,A439 D2								
10	Yoke	GP 240GH	G17CrMo5-5	GS12CrMo 19-5	GX12CrMo 10-1	G17Mn5	G20Mn5	GX5CrNi19-10	GX5CrNiMo19-11-2	
11	Threaded bushing	Carbon steel						Stainless steel		
12	Lantern ring	X12Cr13							GX5CrNi19-10	GX5CrNiMo19-11-2
13	Bolt of gland flange	25CrMo4	25CrMo4	25CrMo4	25CrMo4	25CrMo4	25CrMo4	A193B8,A4-70	A193B8M,A4-70	
14	Bolt	42CrMo4	A193B16	A193B16	A193B16	42CrMo4	26CrMo4	A193B8,A4-70	A193B8M,A4-70	
15	Nut	25CrMo4	25CrMo4	25CrMo4	25CrMo4	25CrMo4	25CrMo4	A194 8,A4-70	A194 8M,A4-70	
16	Nut	25CrMo4	A194 7	A194 7	A194 7	25CrMo4	26CrMo4	A194 8,A4-70	A194 8M,A4-70	
17	Gasket	304 + graphite, 316L + graphite								
18	Stem packing	graphite								
19	Hand wheel	cast iron								

THROUGH CONDUIT GATE VALVES

TYPE S38/S

DIMENSIONS

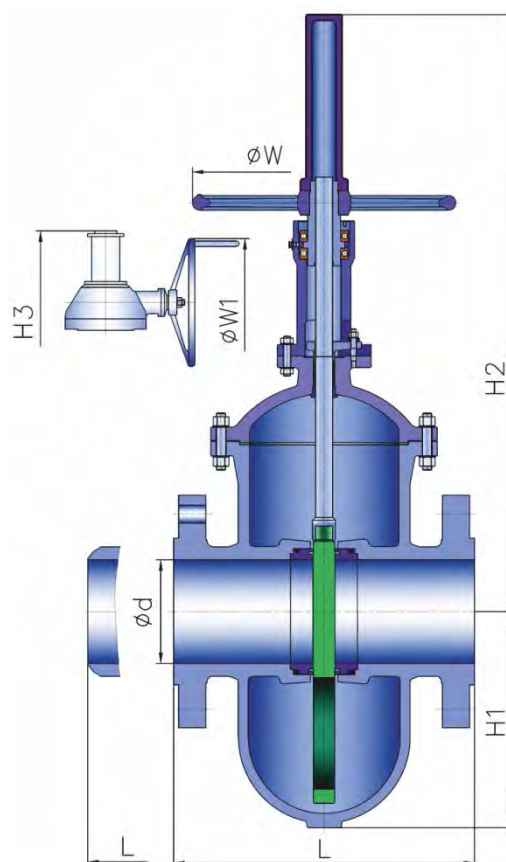

		PN 16, PN 25, CLASS 150									PN 40, CLASS 300								
NPS	DN	L		H1	H2	H3	W	W1	(KG)		L		H1	H2	H3	W	W1	(KG)	
		1	2						2	1	1	2						2	1
1 1/2	40	165	165	115	435	-	250	-	29	33	190	190	115	435	-	250	-	32	35
2	50	178	216	122	475	-	250	-	48	54	216	216	122	575	-	250	-	51	54
2 1/2	65	190	241	152	535	-	300	-	59	70	241	241	152	535	-	300	-	62	70
3	80	203	283	178	600	-	300	-	63	73	283	283	178	600	-	300	-	66	73
4	100	229	305	220	700	-	350	-	73	85	305	305	220	700	-	350	-	78	90
6	150	267	403	345	910	-	350	-	158	180	403	403	345	910	-	350	-	159	180
8	200	292	419	420	1095	1235	350	305	264	300	419	419	420	1095	1235	350	305	266	300
10	250	330	457	495	1370	1510	450	305	290	329	457	457	495	1370	1510	450	305	416	470
12	300	356	502	600	1470	1610	500	305	400	455	502	502	600	1470	1610	500	305	576	650
14	350	381	572	640	1730	1890	600	458	619	704	762	762	640	1730	1890	600	458	890	1005
16	400	406	610	720	1870	2030	650	458	869	987	838	838	720	1870	2030	650	458	1260	1410
18	450	432	660	798	2185	2415	700	458	1115	1267	914	914	798	2185	2415	700	458	1620	1810
20	500	457	711	875	2335	2565	800	458	1435	1631	991	991	875	2335	2545	800	458	2110	2330
24	600	508	813	1250	2815	3045	1000	458	2310	2625	1143	1143	1170	2815	3045	1000	458	3410	3750
28	700	610	914	1250	-	-	-	-	3203	3640	1346	1346	1250	-	-	-	-	4715	5200
32	800	660	965	1370	-	-	-	-	4540	5159	1524	1524	1370	-	-	-	-	6690	7370
36	900	711	1016	1500	-	-	-	-	6209	7056	1727	1727	1500	-	-	-	-	9230	10080
40	1000	813	-	1670	-	-	-	-	7293	8288	-	-	-	-	-	-	-	-	-

THROUGH CONDUIT GATE VALVES

TYPE S38/S

DIMENSIONS

		CLASS 400									PN 63								
NPS	DN	L		H1	H2	H3	W	W1	(KG)		L		H1	H2	H3	W	W1	(KG)	
		1	2						2	1	1	2						2	1
1 1/2	40	241	241	127	457	-	250	-	34	40	241	241	127	457	-	250	-	34	40
2	50	292	292	135	499	-	250	-	51	59	250	292	135	499	-	250	-	51	59
2 1/2	65	330	330	167	562	-	300	-	58	70	290	330	167	562	-	300	-	58	70
3	80	356	356	196	630	-	300	-	84	100	310	356	196	630	-	300	-	84	100
4	100	406	406	242	735	-	350	-	137	165	350	406	242	735	-	350	-	137	165
6	150	495	495	380	956	1096	350	305	210	240	450	495	380	956	1096	350	305	210	240
8	200	597	597	462	1150	1290	400	305	340	385	550	597	462	1150	1290	350	305	340	385
10	250	673	673	545	1439	1580	500	305	505	565	650	673	545	1439	1580	450	305	505	565
12	300	762	762	660	1545	1705	600	458	680	765	750	762	660	1545	1705	500	458	680	765
14	350	826	826	705	1818	197	650	458	1010	1130	850	826	705	1817	1977	600	458	1010	1130
16	400	902	902	792	1965	2125	700	458	1430	1580	950	902	792	1965	2125	650	458	1430	1580
18	450	978	978	878	2295	2525	700	458	1940	2120	1050	978	878	2295	2525	700	458	1940	2120
20	500	1054	1054	963	2452	2682	1000	458	2500	2750	1150	1054	963	2452	2682	800	458	2500	2750
24	600	1232	1232	1287	-	3186	-	458	3710	4050	1350	1232	1287	-	3186	1000	458	3710	4050
28	700	1397	1397	1375	-	-	-	-	5100	5700	1450	1397	1375	-	-	-	-	5100	5700
32	800	1650	1650	1507	-	-	-	-	6920	7547	1650	1651	1507	-	-	-	-	6920	7547
36	900	1880	1880	1650	-	-	-	-	9800	10600	1880	1880	1650	-	-	-	-	9800	10600

		PN 100, CLASS 600									PN 160, CLASS 900								
NPS	DN	L		H1	H2	H3	W	W1	(KG)		L		H1	H2	H3	W	W1	(KG)	
		1	2						2	1	1	2						2	1
1 1/2	40	241	241	127	457	-	250	-	42	46	305	305	140	503	-	300	-	42	45
2	50	292	292	135	499	-	300	-	59	68	368	368	147	550	-	350	-	82	87
2 1/2	65	330	330	167	562	-	350	-	78	90	419	419	184	618	-	400	305	129	136
3	80	356	356	196	630	-	350	-	106	122	381	381	216	693	833	500	305	165	173
4	100	432	432	242	735	-	400	-	134	167	457	457	266	810	950	600	458	237	251
6	150	559	559	380	956	1096	500	305	212	260	610	610	418	1052	1212	650	458	421	443
8	200	660	660	462	1150	1290	600	305	384	484	737	737	508	126	1423	700	458	672	707
10	250	787	787	525	1439	1580	650	458	540	720	838	838	600	1583	1813	800	458	983	1034
12	300	838	838	660	1545	1705	700	458	965	1160	965	965	726	1698	1928	1000	458	1634	1720
14	350	889	889	705	1817	1977	800	458	1305	1620	1029	1029	775	-	2230	-	-	2353	2476
16	400	991	991	792	1965	2125	1000	458	1350	1800	1130	1130	871	-	-	-	-	2613	2750
18	450	1092	1092	878	-	2525	-	458	1950	2440	1219	1219	966	-	-	-	-	3575	3763
20	500	1194	1194	963	-	2682	-	458	2365	2985	1321	1321	1060	-	-	-	-	4331	4559
24	600	1397	1397	1287	-	-	-	-	3800	4740	1549	1549	1416	-	-	-	-	6954	7320
28	700	1549	1549	1375	-	-	-	-	5930	6800	-	-	-	-	-	-	-	-	-
32	800	1778	1778	1507	-	-	-	-	8333	9410	-	-	-	-	-	-	-	-	-

THROUGH CONDUIT GATE VALVES

TYPE S38/S

TYPE DESIGNATION

S38 C/D E M₁ PN or Class/S

C CONNECTION INTO PIPE

- 1 Flanged
- 2 Welded ends
- 8 Combined

M₁ BODY MATERIAL

- 0 Stainless steel
- 2 Cast alloy steel
- 5 Cast carbon steel
- L Carbon steel for low temperatures
- T temperatures

S SPECIAL EXECUTION

- A Antistatic execution
- B Bypass
- O With overflow

D FLANGE FACING

EN 1092 - 1

- A Flat face
- B Raised face
- C Tongue face
- D Groove face
- E Spigot
- F Recess
- G O - ring recess
- H O - ring groove

ANSI B 16.5

- PFF Flat sealing face
- RF Raised face
- LTF Large tongue
- STF Small tongue
- LGF Large groove
- SGF Small groove
- LMF Large male
- SMF Small male
- LFF Large female
- SFF Small female
- RTJ Ring joint

E CONTROL

- 1 Hand wheel
- 2 Gearbox + hand wheel
- 3 Electric actuators
- 4 Gearbox + electric actuators
- 9 Bare shaft





Range DN: 40 ~ 2000
NPS: 1 1/2" ~ 80"



PED 97/23/EC
PED 2014/68/EU



TR TS 10/11,
12/11, 32/11



Range PN: 16 ~ 160
Class: 150 - 300

Operating temperature: Depending on the sealing material

Connection into piping: Flanged, welded ends, WAFER type, LUG type



DESCRIPTION

DE BTF (double eccentric) butterfly valves are controlled shut-off valves. They are designed to stop or allow the flow of the medium by external operation, via either the hand wheel or the installed drive. The medium can flow in one direction only. These butterfly valves are designed and manufactured to ensure maximum service life and reliability.

MATERIAL SPECIFICATION

DE BTF butterfly valves are made from carbon ,alloyed and stainless steels. The material type can be adjusted according to the customer's request to optimally suit the operating conditions.

APPLICATION

DE BTF butterfly valves are suitable for various liquids, gases and steam.

BASIC STANDARDS FOR DESIGN

Basic design

API 609, ASME B16.34

Pressure-temperature rating

ASME B16.34, EN 12 516 - 1

Testing

API 598 EN 12 266 - 1, 2

Face-to-face dimensions

ANSI B16.10, EN 558

Dimensions of the welded ends

ANSI B16.25, EN 12 627

Top Flange dimensions

EN ISO 5211

Flange dimensions

ANSI B 16.5, ANSI B16.47A, EN1092 - 1

Special

NACE MR-0175

DOUBLE ECCENTRIC BUTTERFLY VALVES

TYPE DE BTF

STRUCTURAL DESIGN

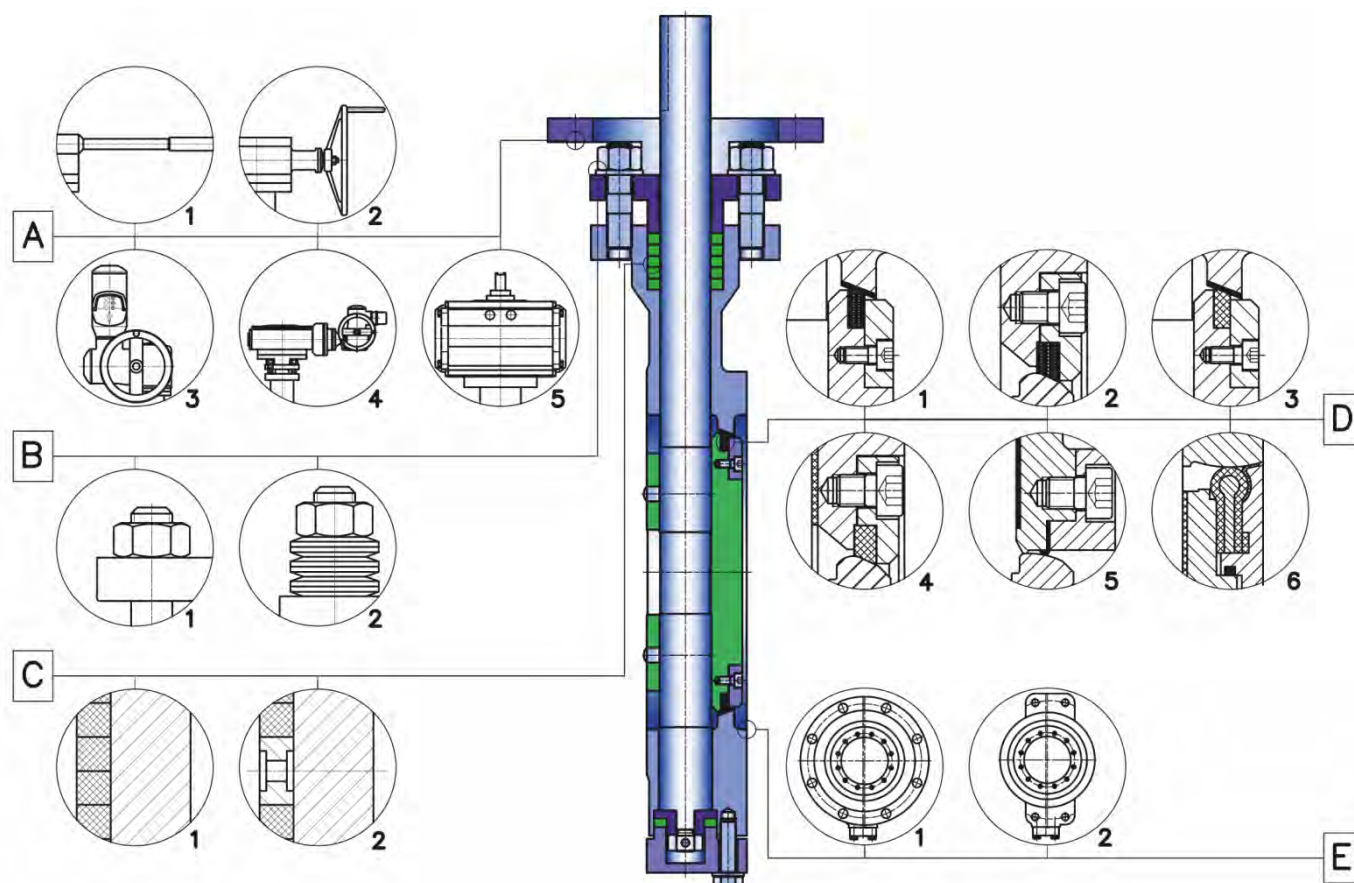

A - Control

- by hand lever into DN 150
- by gearbox
- by electric actuator
- by electric actuator with gear box
- by pneumatic actuator

B – Gland compression

- in case of valve operation with cyclic changes in pressure or at high pressures and temperatures, the gland compression by means of Belleville springs, which secure a constant pre-stress in packing, is preferred.

C - Execution of gland

- standard
- double stem packing with lantern ring – shall be chosen in dependence on working conditions

D – Seat Execution

- PTFE
- Viton
- Stainless steel
- NBR
- EPDM
- Stainless steel + graphite

The seat ring can be placed either in the body or on the disc

E – Connection into piping

- flanged, welded ends, wafer type, lug type

DOUBLE ECCENTRIC BUTTERFLY VALVES

TYPE

DE BTF

MATERIAL SPECIFICATION

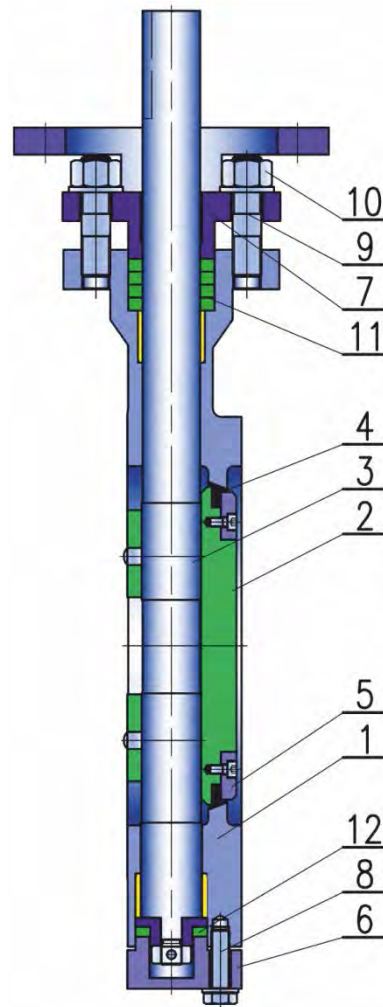

Pos.	Designation	WCB	LCC	LCB	WC6	WC9	C5	C12	CF8 / 304	CF8M / 316
1	Body	A216 WCB	A352 LCC	A352 LCB	A217 WC6	A217 WC9	A217 C5	A217 C12	A351 CF8	A351 CF8M
2	Disc	A216 WCB	A352 LCC	A352 LCB	A217 WC6	A217 WC9	A217 C5	A217 C12	A351 CF8	A351 CF8M
3	Control stem	AISI 420	AISI 420	AISI 420	AISI 420	AISI 420	AISI 420	AISI 420	A182 F304	A182 F316
4	Seat	AISI 430	AISI 430	AISI 430	AISI 430	AISI 430	AISI 430	AISI 430	AISI 304	AISI 316
		+ seat ring (EPDM, NBR, HNBR, VITON, GRAPHITE)								
5	Retaining ring	A216 WCB	A352 LCC	A352 LCB	A217 WC6	A217 WC9	A217 C5	A217 C12	A351 CF8	A351 CF8M
6	Bottom cover	A216 WCB	A352 LCC	A352 LCB	A217 WC6	A217 WC9	A217 C5	A217 C12	A351 CF8	A351 CF8M
7	Gland flange	A216 WCB	A352 LCC	A352 LCB	A217 WC6	A217 WC9	A217 C5	A217 C12	A351 CF8	A351 CF8M
8	Bolt	A193 B7	A320 L7	A320 L7	A193 B16	A193 B16	A193 B16	A193 B16	A193 B8	A193 B8M
9	Bolt	A193 B7	A320 L7	A320 L7	A193 B16	A193 B16	A193 B16	A193 B16	A193 B8	A193 B8M
10	Nut	A194 2H	A194 4	A194 4	A194 B8M	A194 B8M	A194 2H	A194 2H	A194 8	A194 8M
11	Gland packing									
12	Gasket	graphite								

DOUBLE ECCENTRIC BUTTERFLY VALVES

TYPE DE BTF

DIMENSIONS

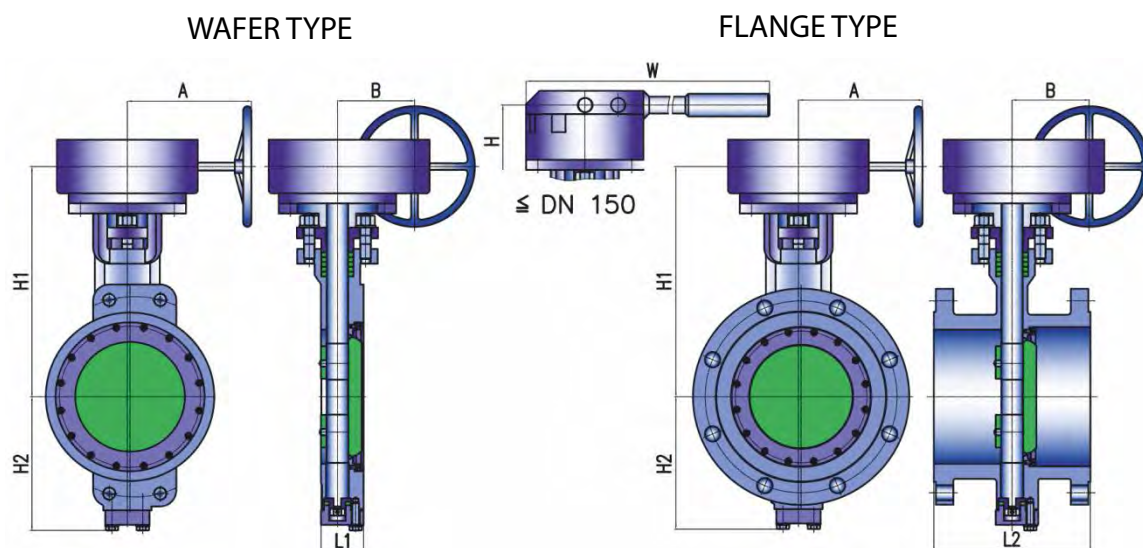

DOUBLE ECCENTRIC BUTTERFLY VALVES

TYPE DE BTF

DIMENSIONS – DE BTF R

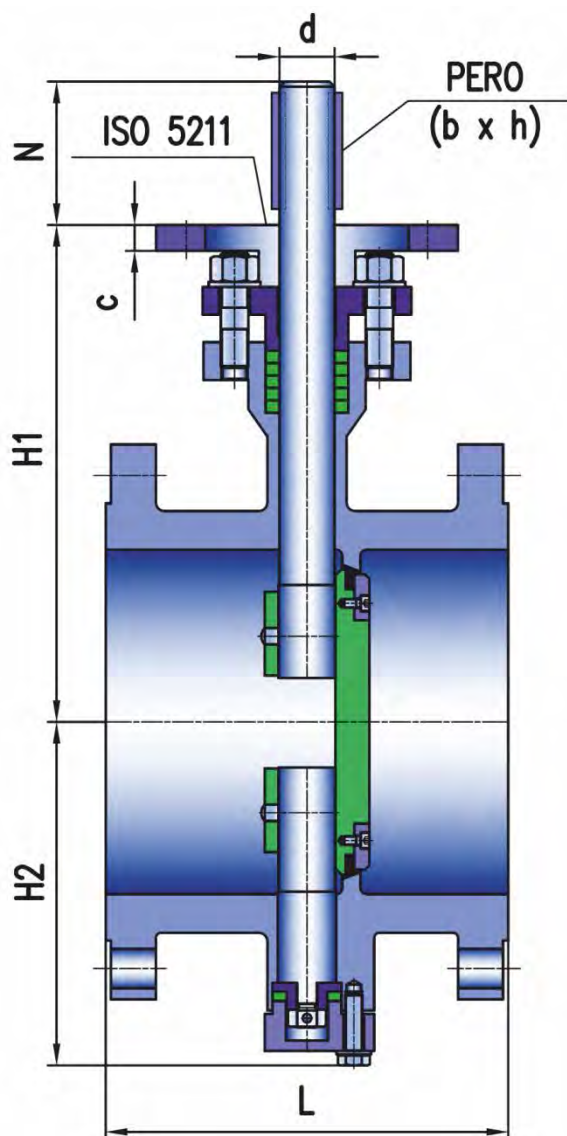

DN	PN 10									
	L	H1	H2	ISO 5211	d	N	c	key		kg
								b	h	
200	230	200	180	F10	25	40	15	8	7	74
250	250	240	200	F12	30	40	20	8	7	114
300	270	255	230	F12	30	50	20	8	7	148
350	290	280	260	F12	35	50	20	10	8	183
400	310	310	300	F12	35	50	20	10	8	215
500	350	375	355	F14	40	70	25	12	8	337
600	390	744	542	F16	50	85	25	14	9	511
700	430	754	510	F16	65	90	25	18	11	905
800	470	824	595	F16	70	90	25	20	12	1221
900	510	916	660	F16	75	100	30	20	12	1576
1000	550	1000	740	F25	80	110	30	22	14	2090
1200	630	1237	880	F25	80	110	30	22	14	2227
1400	710	1367	1013	F25	90	110	35	22	14	2705
1600	790	1638	1113	F25	100	110	35	22	14	4327
1600	790	1638	1113	F25	100	110	35	22	14	4327
2000	950	1820	1350	F25	140	165	40	22	14	4865

DN	PN 16									
	L	H1	H2	ISO 5211	d	N	c	key		KG
								b	h	
200	230	200	180	F10	25	40	15	8	7	74
250	250	240	200	F12	30	50	20	8	7	114
300	270	255	230	F12	35	50	20	10	8	148
350	290	280	260	F12	40	50	20	12	8	183
400	310	310	300	F14	40	70	20	12	8	215
500	350	375	355	F16	50	90	25	14	9	337
600	390	744	542	F25	65	90	25	18	11	511
700	430	754	510	F25	70	110	25	20	12	905
800	470	824	595	F25	85	110	25	22	14	1221
900	510	916	660	F25	90	110	30	25	14	1576
1000	550	1000	740	F30	100	130	30	28	16	2090
1200	630	1237	880	F30	100	130	30	28	16	2227
1400	710	1367	1013	F30	120	130	35	32	18	2705
1600	790	1638	1113	F30	120	130	35	32	18	4327

Standard butterfly valves of type DE BTF and DE BTF R with this design provide tightness in only one direction (in the direction of the arrow on the body). If it is also necessary to ensure tightness in the opposite direction, this requirement should be specified in the order.

DOUBLE ECCENTRIC BUTTERFLY VALVES

TYPE DE BTF

DIMENSIONS

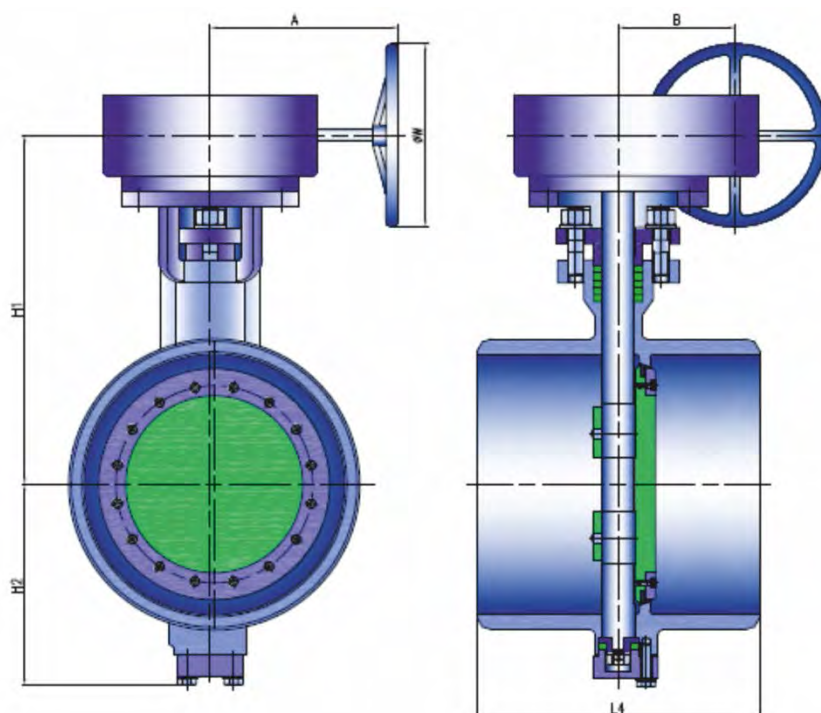

DN	PN 2,5 – 16 Class 150						PN 25, 40 Class 300					
	L4	H1	H2	A	B	kg	L4	H1	H2	A	B	kg
						L1						L1
40		155	49	-	-	3,4		155	49	-	-	3,4
50	150	162	59	-	-	4,1	150	162	59	-	-	5
65	170	179	67	-	-	6	170	179	82	-	-	7,2
80	180	187	89	-	-	7,7	180	187	89	-	-	9
100	190	202	101	-	-	9,8	190	202	108	-	-	12
125	200	218	115	-	-	13	200	218	127	-	-	16
150	210	232	130	-	-	18	210	232	140	-	-	22

DN	PN 2,5 – 16 Class 150						PN 25, 40 Class 300					
	L4	H1	H2	A	B	kg	L4	H1	H2	A	B	kg
						L1						L1
200	230	297	205	170	84	37,5	230	297	205	170	84	37,5
250	250	327	235	170	84	54,5	250	327	235	170	84	54,5
300	270	364	275	200	108	90	270	364	275	200	108	90
350	290	404	309	200	108	116	290	404	309	200	108	116
400	310	444	346	240	128	157	310	444	346	240	128	157
450	330	472	392	240	152	207	330	472	392	240	152	207
500	350	522	427	300	68	269	350	522	427	300	168	269
600	390	608	509	320	192	378	390	608	509	320	192	378
700	430	795	572	332	218	554	-	795	572	332	218	554
800	470	835	638	350	237	673	-	835	638	350	237	673
900	510	885	700	350	237	-	-	885	700	350	237	-
1000	550	945	765	350	237	-	-	945	765	350	237	-

DOUBLE ECCENTRIC BUTTERFLY VALVES

TYPE

DE BTF

TYPE DESIGNATION

DE BTF C E M₁/M₂ PN or CLASS/S

C	CONNECTION INTO PIPE	E	CONTROL	M₁	BODY MATERIAL
	<ul style="list-style-type: none"> 1 Flanged 2 Welding on ends OL Type „LUG“ OW Type „WAFER“ 		<ul style="list-style-type: none"> 1 Hand lever 2 Gearbox+hand wheel 3 Electric actuator 4 Gearbox + electric actuator 5 Pneumatic actuators 6 Hydraulic actuator 9 Without control 		<ul style="list-style-type: none"> 0 Stainless steel 1 Modular cast iron 2 Cast alloy steel 3 Forged alloy steel 4 Forged carbon steel 5 Cast carbon steel 6 Grey cast iron LT Carbon steel for low temperatures
M₂	SEAT RING MATERIAL				
	<ul style="list-style-type: none"> E EPDM N NBR HN HNBR P CR S WMQ T PTFE V VITON 	S	SPECIAL EXECUTION		
			<ul style="list-style-type: none"> As Antistatic execution DT Bi-directional tightness 		



Range DN: 32 ~ 2000
NPS: 1 1/4" ~ 80"



PED 97/23/EC
PED 2014/68/EU



TR TS 10/11,
12/11, 32/11



Range PN: 6 ~ 16
Class: 150

Operating temperature: Depending on the sealing material

Connection into piping: Flanged, WAFER type, LUG type



DESCRIPTION

L32.1(centric) butterfly valves are controlled shut-off valves. They are designed to stop or allow the flow of the medium by external operation, via either the handwheel or the installed drive. The medium can flow in one direction only. These butterfly valves are designed and manufactured to ensure maximum service life and reliability. .

MATERIAL SPECIFICATION

L32.1 butterfly valves are made from carbon ,alloyed and stainless steels. The material type can be adjusted according to the customer's request to optimally suit the operating conditions

APPLICATION

L32.1 butterfly valves are suitable for various liquids, gases and steam.

BASIC STANDARDS FOR DESIGN

Basic design

API 609, MSS SP 67, EN 593

Pressure-temperature rating

ASME B16.34, EN 12 516 - 1

Testing

API 598 EN 12 266 - 1, 2

Face-to-face dimensions

EN 558

Dimensions of the welded ends

ANSI B16.25, EN 12 627

Top Flange dimensions

EN ISO 5211

Flange dimensions

ANSI B 16.5, EN 1759 - 1,
EN1092 - 1

Special

NACE MR-0175

CENTRIC BUTTERFLY VALVES

TYPE L32.1

STRUCTURAL DESIGN

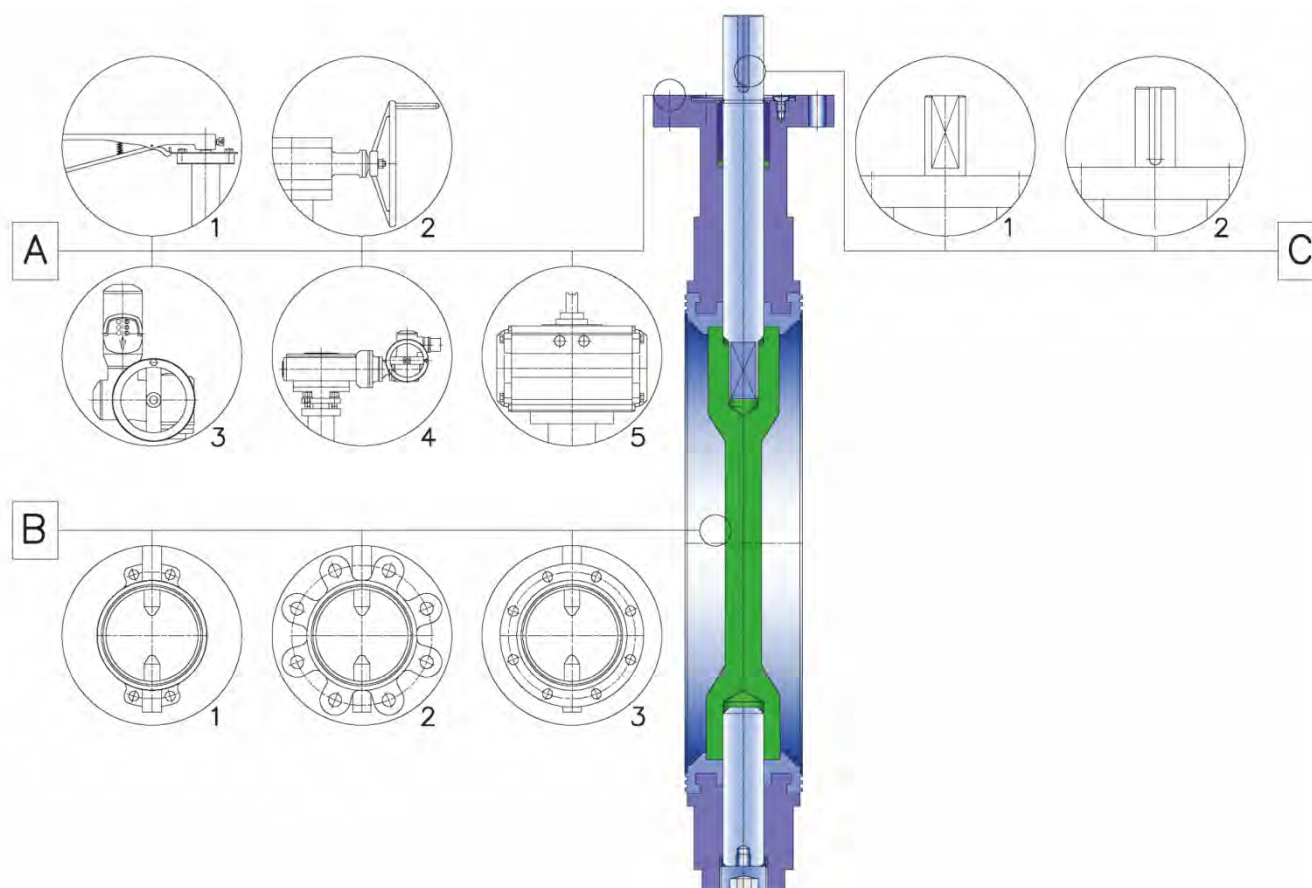

A - Control

- by hand lever for DN 40 up to DN 300
- by hand gear-box for DN 250 up to DN 2000
- by electric actuator
- by electric actuator with gear-box
- by pneumatic actuator

B - Execution

- Wafer type
- Lug type
- Flanged type "U"

C - Stem execution

- the upper stem with 2 contact surfaces for valves up to DN 200 inclusive
- the upper stem with feather for valves DN 250 and above

ADVANTAGES OF THESE PRODUCTS

- Excellent both-sides tightness of the closure
- Cheap option in comparison with gate, ball or globe valve
- Very good corrosion resistance, body and stems are not in the contact with working medium
- Outside surface protection secured by epoxy paint coating
- Self-centering of the disc due to its floating embedding
- No need for flange gaskets for installation, their function is replaced by the seat
- Low weight
- Anti blow out stem-upper control stem is secured against forcing out the body by means of thrust collar
- Easy replaceable seat without need of any special tools
- Easy installation of each type of actuators
- Wide range of material executions suitable for various working conditions
- Self cleaning function
- Low pressure drop and small turbulence of the flow
- Possibility of regulation of the flow

CENTRIC BUTTERFLY VALVES

TYPE L32.1

MATERIAL SPECIFICATION

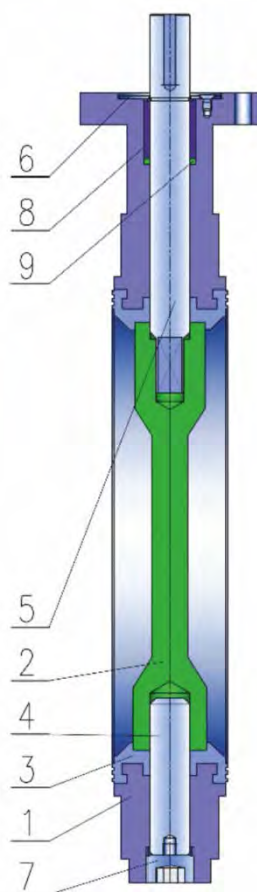

Pos.	Designation	Material		
		EN	ČSN	ASTM
1.	Body	EN-JL 1020 EN-JL 1040 EN-JS 1030 1.0619 (P240GH) 1.4308 (GX5CrNi19-10) 1.4408 (GX5CrNiMo19-11-2)	42 2415 42 2425 42 2304 42 2643 42 2930 42 2940	A 48 A 278 No. 35 A 536 60-40-18 A 216 WCB A 351 CF8 A351 CF8 M B 275 B148 Cl.9D
2.	Disc	EN-JS 1030 EN-JS 1030 1.4308 (GX5CrNi19-10) 1.4408 (GX5CrNiMo 19-11-2)	42 2304 42 2305 42 2930 42 2940	A 536 60-40-18 A 536 65-45-12 A 351 CF8 A 351 CF8M BS 1400 AB1, AB2
3.	Seat-Cuff	EPDM (-35°C ~ +120°C) NBR (-20°C ~ +90°C) WMQ (-20°C ~ +160°C) VITON (-10°C ~ +160°C) TFE (-35°C ~ +160°C) CR (-35°C ~ 90°C)		
4.	Control Upper Stem	1.4301 (X5CrNi18-10) 1.4542 (X5CrNiCuNb 16-4) 1.4005 (X10Cr13)	41 7240 X5CrNiCuNb 16-4 17 021 (41 7021)	A 479 TYPE 304 A 564 TYPE 630 410
5.	Bottom Stem	1.4301 (X5CrNi18-10) 1.4542 (X5CrNiCuNb 16-4) 1.4005 (X10Cr13)	41 7240 X5CrNiCuNb 16-4 17 021 (41 7021)	A 479 TYPE 304 A 564 TYPE 630 410
6.	Retainer Plate	Silicon iron		
7.	Plug	Silicon iron		
8.	Bushing	DELTRIN		
9.	Seal	NBR VITON		

CENTRIC BUTTERFLY VALVES

TYPE L32.1

DIMENSIONS

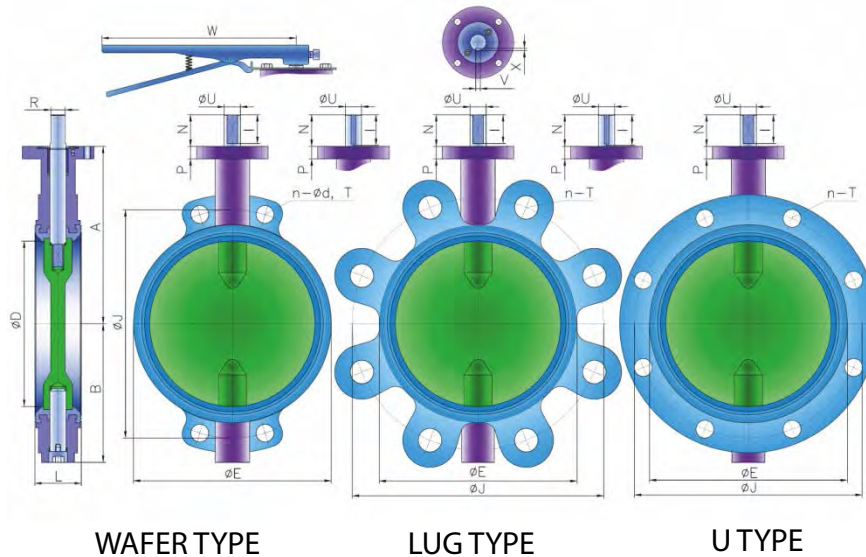
WAFER TYPE
LUG TYPE
U TYPE

Diameter		Ø D	L	A	B	Ø E	P	Control Stem							Top flange ISO 5211	W	Weight(KG)		
NPS	DN							Ø U	N	L	R	X	V	Key			Type of valve		
																	„WAFER“	„LUG“	„U“
1 1/4	32	32	33	87	46	---	10	11	33	30	9,5	-	-	-	F05	230	2,5	3,2	4
1 1/2	40	40	40	120	60	85	10	14	33	30	9,5	-	-	-	F07	265	2,7	3,7	6
2	50	50	43	130	75	92	11	14	33	30	9,5	-	-	-	F07	265	2,9	4,2	6,5
2 1/2	65	63	46	137	80	107	11	14	33	30	9,5	-	-	-	F07	265	4,1	5,7	9
3	80	77	46	156	95	122	11	16	33	30	11,8	-	-	-	F07	265	4,4	8,7	10
4	100	100	52	170	110	150	11	16	33	30	11,8	-	-	-	F07	265	4,7	9,2	14
5	125	125	56	185	123	179	12	19	33	30	14,5	-	-	-	F07	265	6,3	12,7	16,5
6	150	147	56	203	143	206	12	19	33	30	14,5	-	-	-	F07	265	7,9	13,7	19
8	200	198	60	238	168	257	13	19	33	30	14,5	-	-	-	F07	315	12,3	22	32
10	250	245	68	270	203	316	15	22	65	60	-	4	8	8 x 7	F10	450	19,2	28	46
12	300	295	78	310	242	370	15	28	65	60	-	4	8	8 x 7	F10	450	30,2	45	58
14	350	332	78	330	280	410	17	28	65	60	-	4	8	8 x 7	F10	-	55	74	94
16	400	384	102	375	320	468	20	38	75	70	-	5	12	12 x 8	F14	-	80	113	130
18	450	434	114	400	350	527	20	38	75	70	-	5	12	12 x 8	F14	-	110	145	160

Diameter		PN 6				PN 10				PN 16			
NPS	DN	Ø J	n	Ø d	T	Ø J	n	Ø d	T	Ø J	n	Ø d	T
1 1/4	32	90	4	14	M12	100	4	19	M16	100	4	19	M16
1 1/2	40	100	4	14	M12	110	4	19	M16	110	4	19	M16
2	50	110	4	14	M12	125	4	19	M16	125	4	19	M16
2 1/2	65	130	4	14	M12	145	4	19	M16	145	4	19	M16
3	80	150	4	19	M16	160	8	19	M16	160	8	19	M16
4	100	170	4	19	M16	180	8	19	M16	180	8	19	M16
5	125	200	8	19	M16	210	8	19	M16	210	8	19	M16
6	150	225	8	19	M16	240	8	23	M20	240	8	23	M20
8	200	280	8	19	M16	295	8	23	M20	295	12	23	M20
10	250	335	12	19	M16	350	12	23	M20	355	12	28	M24
12	300	395	12	23	M20	400	12	23	M20	410	12	28	M24
14	350	445	12	23	M20	460	16	23	M20	470	16	28	M24
16	400	495	16	23	M20	515	16	28	M24	525	16	31	M27
18	450	550	16	23	M20	565	20	28	M24	585	20	31	M27

CENTRIC BUTTERFLY VALVES

TYPE L32.1

DIMENSIONS

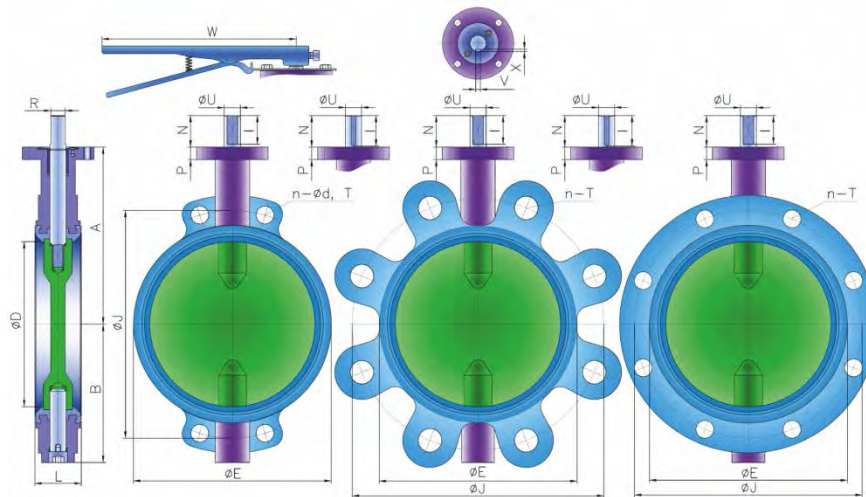
WAFER TYPE
LUG TYPE
U TYPE

Diameter		Ø D	L	A	B	Ø E	P	Control Stem						Top flange ISO 5211	Weight(KG)		
NPS	DN							Ø U	N	L	X	V	Key		Type of valve		
															„WAFER“	„LUG“	„U“
20	500	487	127	440	380	578	22	40	100	90	5,5	14	14 x 9	F16	145	215	215
22	550	530	142	475	410	636	22	45	100	90	5,5	14	14 x 9	F16	200	275	280
24	600	575	154	510	440	680	22	50	100	90	5,5	14	14 x 9	F16	235	345	335
26	650	625	165	530	455	735	28	50	100	90	5,5	14	14 x 9	F16	310	430	420
28	700	673	165	580	480	785	30	55	100	90	5,5	14	14 x 9	F16	330	475	470
30	750	731	192	585	535	845	30	60	140	100	7,5	20	20 x 12	F25	385	610	585
32	800	767	190	630	570	895	35	75	140	130	7,5	20	20 x 12	F25	460	715	700
34	850	824	200	660	620	945	38	75	140	130	7,5	20	20 x 12	F25	565	760	745
36	900	860	203	700	670	1000	38	75	140	130	7,5	20	20 x 12	F25	630	830	810
40	1000	970	216	750	725	1095	38	90	140	130	9,0	25	25 x 14	F25	825	990	960
42	1050	1010	216	820	750	1154	40	90	140	130	9,0	25	25 x 14	F25	860	1215	1000
48	1200	1173	254	900	860	1310	45	90	140	130	9,0	25	25 x 14	F25	910	1450	1265
56	1400	1386	330	1000	949	1540	50	130	160	150	11,1	32	32 x 18	F 35	-	1928	1742
64	1600	1586	360	1150	1120	1754	50	140	160	150	12,3	36	36 x 20	F 35	-	1983	1806
72	1800	1776	360	1270	1221	1982	55	160	180	170	13,5	40	40 x 22	F 35	-	2612	2374
80	2000	1976	520	1425	1437	2210	60	180	200	190	15,3	45	45 x 25	F 40	-	3822	3560

Diameter		PN 6					PN 10				PN 16			
NPS	DN	Ø J	n	Ø d	T	Ø J	n	Ø d	T	Ø J	n	Ø d	T	
20	500	600	20	22	M20	620	20	28	M24	650	20	33	M30	
24	600	705	20	26	M24	725	20	30	M27	770	20	36	M33	
28	700	810	24	26	M24	840	24	30	M27	840	24	36	M33	
32	800	920	24	30	M27	950	24	33	M30	950	24	39	M36	
36	900	1020	24	36	M27	1050	28	33	M30	1050	28	39	M36	
40	1000	1120	28	30	M27	1160	28	36	M33	1170	28	42	M39	
48	1200	1340	32	33	M30	1380	32	39	M36	1390	32	48	M45	
56	1400	1560	36	36	M33	1590	36	42	M39	1590	36	48	M45	
64	1600	1760	40	36	M33	1820	40	48	M45	1820	40	56	M52	
72	1800	1970	44	39	M36	2020	44	48	M45	2020	44	56	M52	
80	2000	2180	48	42	M39	2230	48	48	M45	2230	48	62	M56	

CENTRIC BUTTERFLY VALVES

TYPE L32.1

TYPE DESIGNATION

L32.1 C E M₁/M₂ - PN or Class

C	CONNECTION INTO PIPE	E	CONTROL	M ₁	MATERIAL OF BODY AND DISC
1	Flanged type "U"	1	Hand lever	0	Stainless steel
0L	„Lug“ type	2	Gearbox + hand wheel	1	Modular cast iron
0W	„Wafer“ type	3	Electric actuator	1Ni	Modular cast iron with Ni surface
		4	Gearbox + electric actuator	2	Cast alloy steel
		5	Pneumatic actuator	5	Cast carbon steel
		6	Hydraulic actuator	LT	Carbon steel for low temperatures
		9	Without control	6	Grey and malleable cast iron

M ₂	SEAT CUP MATERIAL
E	EPDM
N	NBR
HN	HNBR
P	CR
S	WMQ
T	PTFE
V	VITON





Range DN: 50 ~ 2000
NPS: 2" ~ 80"



Range PN: 6 ~ 100
Class: 150 ~ 600



PED 97/23/EC
PED 2014/68/EU



TR TS 10/11,
12/11, 32/11



EN 12 569
CERTIFICATE



CERTIFICATE
API 607, 6FA

Operating temperature: - 196 °C ~ + 550 °C

Connection into piping: Flanged, WAFER, LUG, welded ends, combined execution



DESCRIPTION

TE BTF (Triple-offset eccentric) BUTTERFLY valves are controlled shut-off valves. They are designed to stop or allow the flow of the medium by external operation, either manually or via the installed drive. The medium can flow in one direction only. These valves are designed and manufactured to ensure maximum service life and reliability.

MATERIAL SPECIFICATION

TE BTF BUTTERFLY valves are made from carbon, alloy and stainless steels. The material type can be adjusted according to the customer's request to optimally suit the operating conditions.

APPLICATION

TE BTF BUTTERFLY valves are suitable for various liquids, gases and steam.

BASIC STANDARDS FOR DESIGN

Basic design

API 609

Pressure-temperature rating

EN 12 516 - 1, ANSI B16.34

Testing

EN 12 266 - 1, 2

Face-to-face dimensions

EN 558, EN 12 982, ANSI B16.10

Dimensions of the welded ends

EN 12 627, ANSI B16.25

Top Flange dimensions

EN ISO 5211

Flange dimensions

EN 1092 - 1, ANSI B16.47
EN 1759 - 1

Special

NACE MR-0175

TRIPLE ECCENTRIC BUTTERFLY VALVES

TYPE TE BTF

STRUCTURAL DESIGN

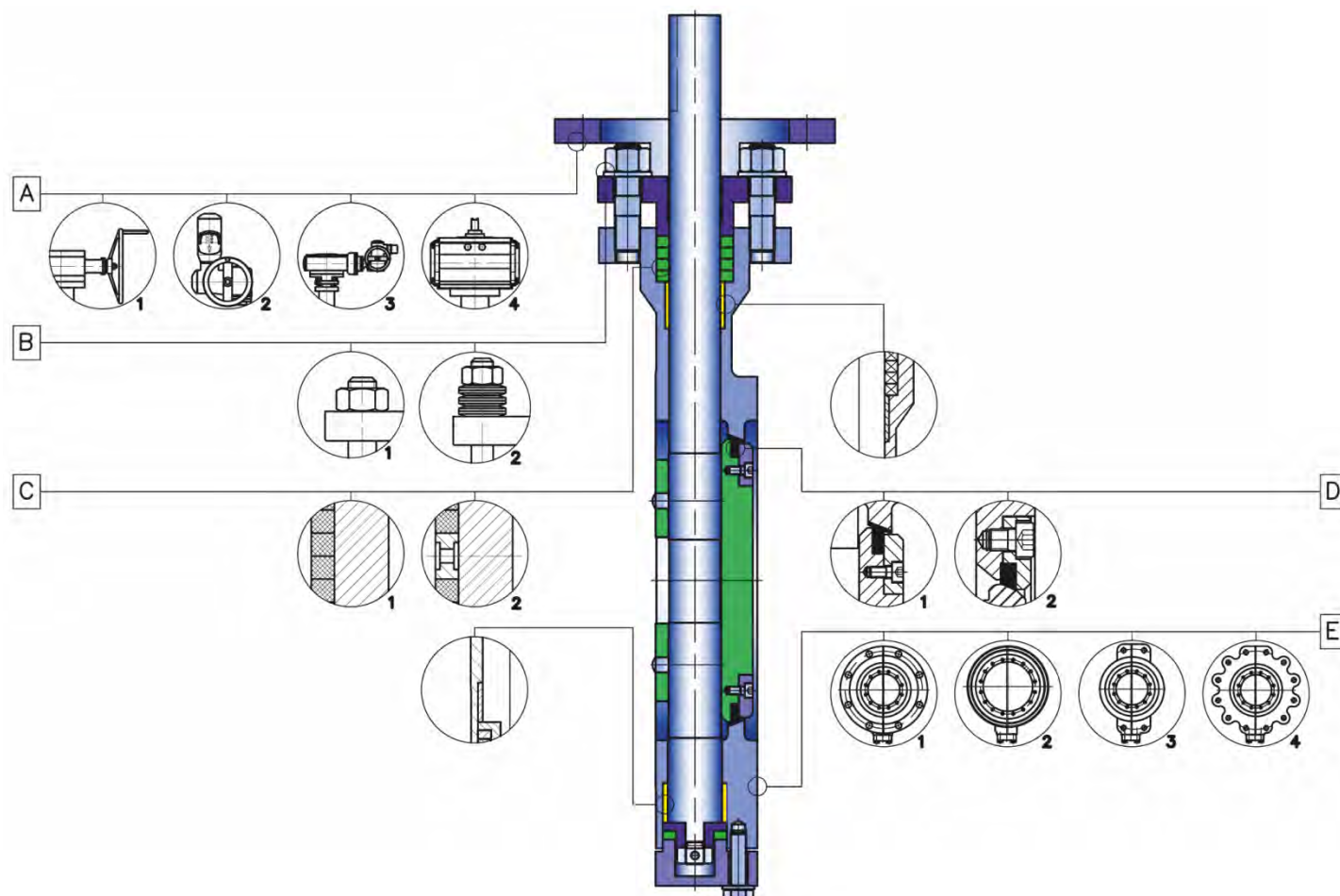

A - Control

- by gearbox
- by electric actuator
- by electric actuator with gear box
- by pneumatic actuator

B - Gland compression

- for valve operation with cyclic changes in pressure or at high pressures and temperatures, gland compression by means of Belleville springs, which ensure a constant pre-stress in packing, is preferred.

C - Execution of gland

- standard
- double stem packing with lantern ring – shall be chosen in accordance with working conditions.

D - Seat Execution

- the tightness of the closure is ensured by a sealing ring, consisting of layers of stainless steel and graphite. The sealing ring can be placed on disc or embedded in the body seat area.

E - Connection to piping

Flanged

LUG or WAFER execution

Welded

- with welded ends according to client's requirement

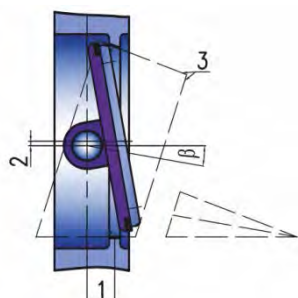

Principle of seating

The principle of seating of triple-offset butterfly valves is based on the design of double-offset butterfly valves where the axis of the stem does not coincide with the axis of the seat and with the axis of the pipeline. The triple eccentricity is given by angle β . In view of this combination of eccentricity the immediate adherence or detachment of the sealing surfaces occurs during the disk movement. As a result, the friction between the seat and the disk during the whole disk movement (90°) is completely eliminated and mechanical wear is decreased. These characteristics improve dramatically the sealing ability and service life of these valves

TRIPLE ECCENTRIC BUTTERFLY VALVES

TYPE TE BTF

MATERIAL SPECIFICATION

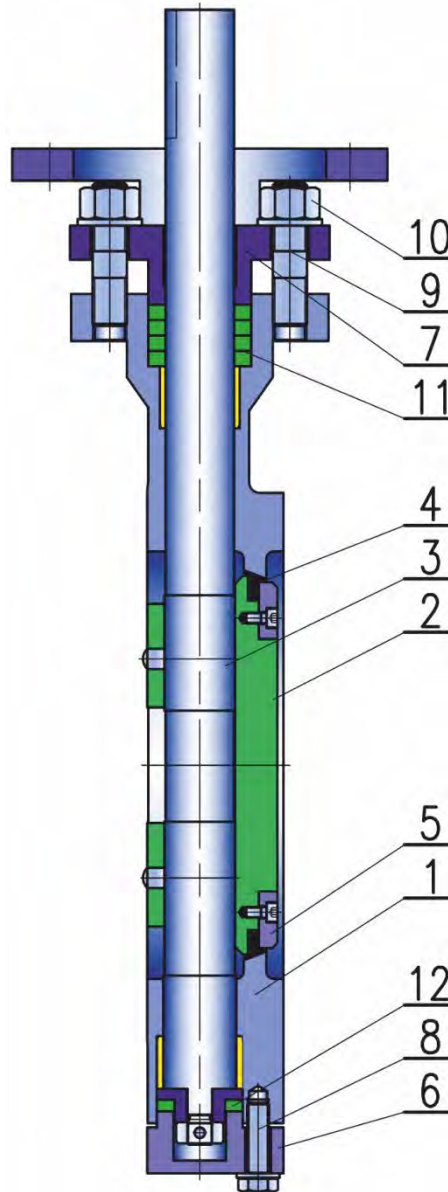

Pos.	Designation	WCB	LCC	LCB	WC6	WC9	C5	C12	CF8 / 304	CF8M / 316
1	Body	A216 WCB	A352 LCC	A352 LCB	A217 WC6	A217 WC9	A217 C5	A217 C12	A351 CF8	A351 CF8M
2	Disc	A216 WCB	A352 LCC	A352 LCB	A217 WC6	A217 WC9	A217 C5	A217 C12	A351 CF8	A351 CF8M
3	Stem	AISI 420	AISI 420	AISI 420	AISI 420	AISI 420	AISI 420	AISI 420	A182 F304	A182 F316
4	Seat	AISI 430 + graphite	AISI 430 + graphite	AISI 430 + graphite	AISI 430 + graphite	AISI 430 + graphite	AISI 430 + graphite	AISI 430 + graphite	AISI 304 + graphite	AISI 316 + graphite
5	Retaining ring	A216 WCB	A352 LCC	A352 LCB	A217 WC6	A217 WC9	A217 C5	A217 C12	A351 CF8	A351 CF8M
6	Bottom cover	A216 WCB	A352 LCC	A352 LCB	A217 WC6	A217 WC9	A217 C5	A217 C12	A351 CF8	A351 CF8M
7	Gland flange	A216 WCB	A352 LCC	A352 LCB	A217 WC6	A217 WC9	A217 C5	A217 C12	A351 CF8	A351 CF8M
8	Bolt	A193 B7	A320 L7	A320 L7	A193 B16	A193 B16	A193 B16	A193 B16	A193 B8	A193 B8M
9	Bolt	A193 B7	A320 L7	A320 L7	A193 B16	A193 B16	A193 B16	A193 B16	A193 B8	A193 B8M
10	Nut	A194 2H	A194 4	A194 4	A194 B8M	A194 B8M	A194 2H	A194 2H	A194 8	A194 8M
11	Gland packing	graphite								
12	Gasket	graphite								

TRIPLE ECCENTRIC BUTTERFLY VALVES

TYPE TE BTF

DIMENSIONS

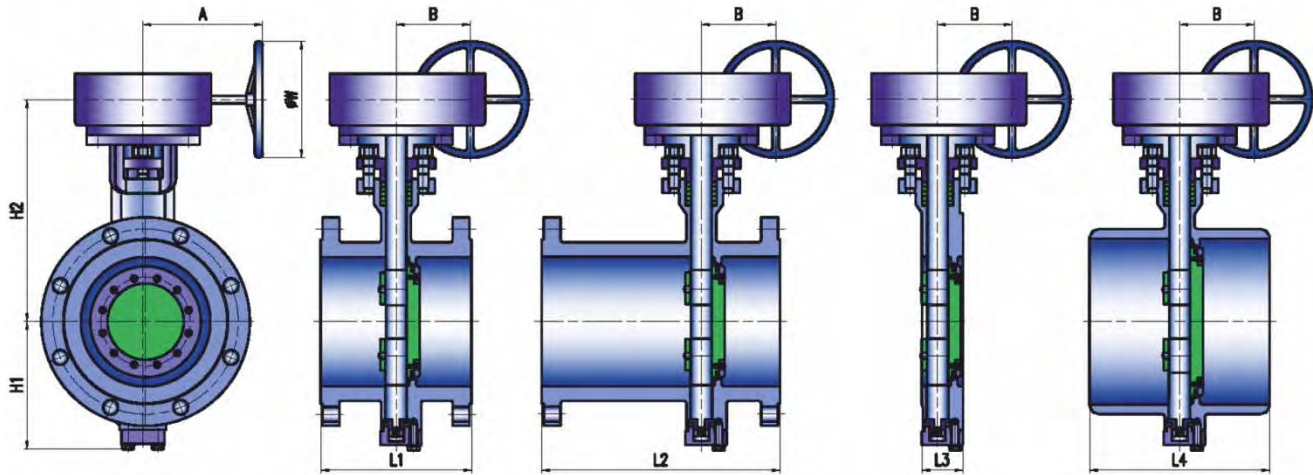

STANDARD FLANGED - DF

WITH LONGER BUILD LENGTH
FLANGED - DFLLUG and WAFER
TYPE

WELDED - BW

Diameter		CLASS 150									(kg)				
NPS	DN	L1	L2	L3	L4	H1	H2	A	B	W	DF	DFL	LUG	WAFER	BW
2	50	108	178	43	150	60	162	214	67	250	26	-	22	24	23
2 1/2	65	112	191	46	170	80	178	214	67	250	26	-	22	24	25
3	80	114	203	50	180	90	186	214	67	250	27	30	22	24	27
4	100	127	229	54	190	100	217	214	67	250	31	34	29	25	32
5	125	140	254	60	200	113	233	214	67	250	40	44	31	27	35
6	150	140	267	60	210	130	263	214	67	250	49	54	32	27	40
8	200	152	292	64	230	206	355	243	97	300	80	88	62	44	63
10	250	165	330	71	250	233	388	243	97	300	106	119	93	60	82
12	300	178	356	81	270	262	420	243	97	300	138	158	99	85	107
14	350	190	381	92	290	296	454	380	88	500	182	192	131	126	145
16	400	216	406	102	310	334	528	380	105	600	230	261	146	174	189
18	450	222	432	114	330	364	553	440	123	500	287	324	180	232	239
20	500	229	457	127	350	415	608	475	140	600	362	415	229	311	308
24	600	267	508	152	390	484	682	520	165	600	510	581	247	467	442
26	650	267	559	154	390	530	707	510	159	600	600	677	653	561	523
28	700	292	610	167	430	574	757	544	217	600	730	841	615	693	642
30	750	318	610	177	470	630	936	658	169	700	846	947	796	825	746
32	800	318	660	190	470	643	837	658	169	700	970	1079	830	933	855
34	850	318	711	196	510	665	969	658	169	700	1186	1275	908	1144	1053
36	900	330	711	203	510	700	995	696	285	700	1337	1475	1071	1288	1184
40	1000	410	762	219	550	796	1021	696	285	700	1690	1867	1419	1614	1487
48	1200	470	-	254	-	860	1174	696	285	700	2200	-	1845	-	-

TRIPLE ECCENTRIC BUTTERFLY VALVES

TYPE TE BTF

DIMENSIONS

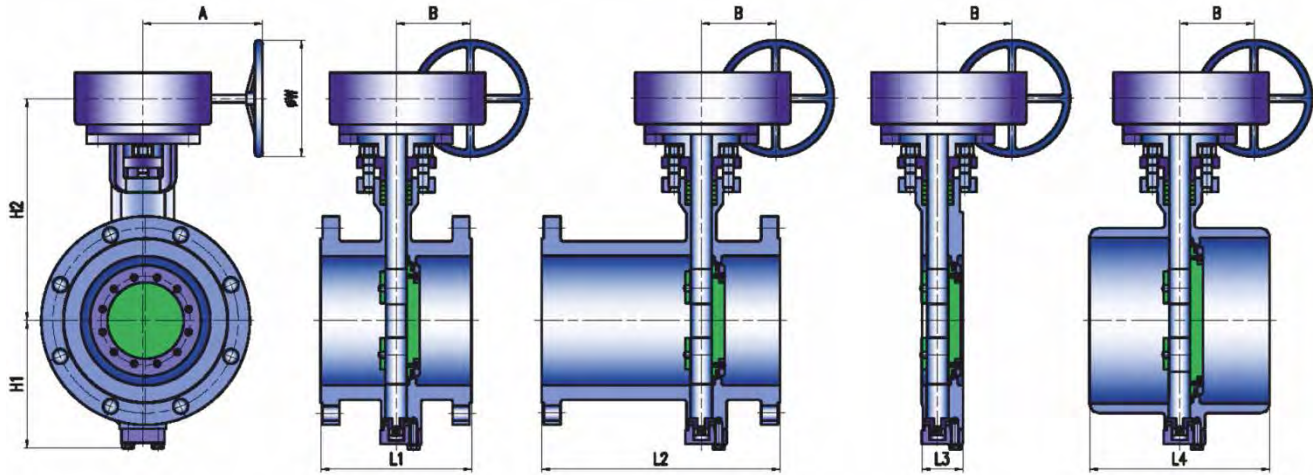

STANDARD FLANGED - DF

WITH LONGER BUILD LENGTH
FLANGED - DFLLUG and WAFER
TYPE

WELDED - BW

Diameter		CLASS 300									(kg)				
NPS	DN	L1	L2	L3	L4	H1	H2	A	B	W	DF	DFL	LUG	WAFER	BW
2	50	108	216	43	150	60	162	214	67	250	27	-	24	24	23
2 1/2	65	112	241	46	170	80	178	214	67	250	27	-	26	24	27
3	80	114	282	50	180	90	186	214	67	250	28	30	27	26	33
4	100	127	305	54	190	100	217	214	67	250	37	42	27	26	41
5	125	140	381	59	200	113	233	214	67	250	56	63	33	31	50
6	150	140	403	60	210	130	263	243	97	300	68	77	50	42	71
8	200	152	419	73	230	206	355	243	97	300	95	110	80	65	99
10	250	165	457	83	250	233	388	380	105	600	140	163	127	112	144
12	300	178	502	92	270	262	420	440	123	500	207	267	177	132	197
14	350	190	762	117	290	296	454	475	140	600	298	369	148	198	279
16	400	216	838	133	310	334	528	510	156	600	375	508	318	270	357
18	450	222	914	149	330	364	553	510	159	600	464	652	402	292	450
20	500	229	991	162	350	415	608	544	217	600	552	777	499	402	559
24	600	267	1143	184	390	484	682	673	293	700	887	1255	877	617	873
26	650	267	1245	210	390	530	707	670	293	700	1115	1587	1065	1005	1123
28	700	292	1346	229	430	574	757	696	285	700	1320	1917	1270	1170	1326
30	750	318	1397	300	470	630	936	673	245	700	1390	2230	1610	1345	1549
32	800	-	-	-	-	660	1000	673	245	700	1475	-	-	-	-
Diameter		CLASS 600									(kg)				
NPS	DN	L1	L2	L3	L4	H1	H2	A	B	W	DF	DFL	LUG	WAFER	BW
2	50	150	-	43	150	60	162	195	63	160	27	-	-	16	23
2 1/2	65	170	-	46	170	80	178	195	63	160	28	-	-	26	25
3	80	180	356	54	180	135	286	214	67	250	40	42	28	28	30
4	100	190	432	64	190	190	385	214	67	250	70	74	47	33	46
5	125	200	508	70	200	205	422	243	97	300	100	105	60	47	71
6	150	210	559	78	210	235	470	243	97	300	128	134	90	70	79
8	200	230	660	102	230	267	468	380	88	500	210	221	130	127	100
10	250	250	787	117	250	300	556	440	123	500	355	373	290	202	200
12	300	270	838	140	270	345	590	475	140	600	435	457	369	260	300
14	350	290	889	155	290	385	624	510	156	600	560	588	500	331	394
16	400	310	991	178	310	420	653	520	134	600	741	778	660	427	498
18	450	330	1092	200	330	475	709	658	169	700	900	945	830	544	600
20	500	350	1194	216	350	525	874	658	169	700	1244	1306	1150	665	750
24	600	390	1397	232	390	610	999	673	245	700	1800	1890	1610	175	1050

TRIPLE ECCENTRIC BUTTERFLY VALVES

TYPE TE BTF

DIMENSIONS

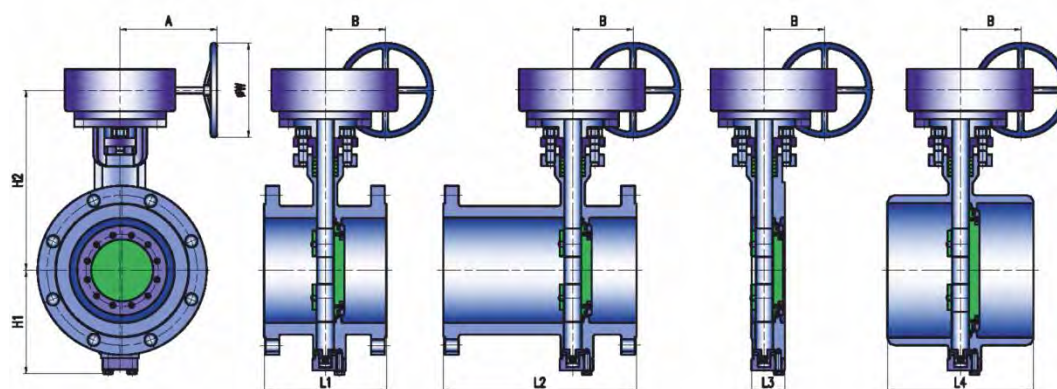

STANDARD FLANGED - DF

WITH LONGER BUILD LENGTH
FLANGED - DFLLUG and WAFER
TYPE

WELDED - BW

Diameter	PN 6, 10, 16									(kg)			PN 25, 40									(kg)		
	L1	L2	L3	H1	H2	A	B	W	DF	WAF	BW	L1	L2	L3	H1	H2	A	B	W	DF	WAF	BW		
50	108	43	150	60	162	140	63	160	24	16	23	108	43	150	60	162	195	63	160	28	22	23		
65	112	46	170	80	178	140	63	160	26	20	25	112	46	170	80	178	195	63	160	30	22	25		
80	114	50	180	90	186	140	63	160	30	22	27	114	64	180	90	186	195	63	160	32	22	27		
100	127	54	190	100	195	140	63	160	38	29	34	127	64	190	100	217	195	63	160	40	29	34		
125	140	60	200	113	208	140	63	160	45	31	41	142	70	200	113	233	250	63	200	48	31	41		
150	140	60	210	130	240	140	63	160	48	32	43	142	76	210	130	263	250	63	300	51	32	43		
200	152	64	230	205	260	150	84	160	74	62	81	152	89	230	203	355	20	84	300	95	62	81		
250	165	71	250	235	295	150	84	200	114	93	102	165	114	250	233	388	280	84	300	120	93	102		
300	178	81	270	275	340	200	108	200	148	99	132	178	114	270	262	420	315	108	300	156	99	132		
350	190	92	290	309	383	200	108	250	183	131	155	190	127	290	296	454	315	108	400	193	131	155		
400	216	102	310	356	427	240	152	300	215	146	193	216	140	310	334	528	320	152	400	227	146	193		
500	229	127	350	427	499	300	168	400	337	229	330	229	152	350	415	608	320	168	400	355	229	330		
600	267	152	390	484	574	500	216	450	511	347	460	267	178	390	474	682	500	216	450	538	347	460		
700	292	167	430	574	643	500	216	450	905	615	830	292	229	430	574	757	500	216	450	953	615	830		
800	318	190	670	643	700	500	216	450	1221	830	1100	318	241	670	653	837	500	216	450	1286	830	1100		
900	330	203	710	700	796	630	320	630	1576	1071	1450	330	241	710	700	935	630	320	630	1659	1074	1450		
1000	410	219	750	735	860	630	320	630	2090	1419	1910	410	300	750	796	1021	630	320	630	2200	1419	1910		
1200	470	254	790	860	885	630	320	630	2227	1845	1977	-	-	-	-	-	-	-	-	-	-	-		

Diameter	PN 63									(kg)			PN 100									(kg)		
	L1	L2	L3	H1	H2	A	B	W	DF	WAF	BW	L1	L2	L3	H1	H2	A	B	W	DF	WAF	BW		
50	108	54	150	60	162	195	63	160	40	16	16	108	54	150	60	162	195	63	160	40	16	16		
65	112	54	170	80	178	195	63	160	48	26	20	112	54	170	80	178	195	63	160	48	26	20		
80	114	57	180	90	186	195	63	160	51	33	22	114	57	180	90	186	195	63	160	51	36	22		
100	127	64	190	100	217	195	63	160	95	40	29	127	64	190	100	217	195	63	160	95	45	29		
125	140	70	200	113	233	250	63	200	120	52	31	140	70	200	113	233	250	63	200	120	60	31		
150	140	76	210	130	263	250	63	300	156	60	32	140	76	210	130	263	250	63	300	156	78	32		
200	152	95	230	206	355	280	84	300	193	120	62	152	95	230	206	355	280	84	300	193	140	62		
250	165	108	250	233	388	280	84	300	227	198	93	165	108	250	233	388	280	84	300	227	210	93		
300	178	143	270	262	420	315	108	300	355	280	99	178	143	270	262	420	315	108	300	355	292	99		

TRIPLE ECCENTRIC BUTTERFLY VALVES

TYPE

TE BTF

TYPE DESIGNATION

TE BTF C E M₁ PN or CLASS/S

C CONNECTION INTO PIPE	E CONTROL	M₁ BODY MATERIAL
<ul style="list-style-type: none"> 1 Flanged 2 Welded 0L Type "LUG" 0W Type "WAFER" 	<ul style="list-style-type: none"> 1 Hand lever 2 Gearbox + hand wheel 3 Electric actuator 4 Gearbox + electric actuator 5 Pneumatic actuators 6 Hydraulic actuator 9 Without control 	<ul style="list-style-type: none"> 0 Stainless steel 2 Cast steel alloy 3 Forged steel alloy 4 Forged carbon steel 5 Cast carbon steel LT Carbon steel for low temperatures
S SPECIAL EXECUTION		
<ul style="list-style-type: none"> As Antistatic execution DL Long building length DT Bi-directional tightness 		





Range NPS: 1/4" ~ 40"



PED 97/23/EC
PED 2014/68/EU



TR TS 10/11,
12/11, 32/11



Range Class: 150 ~ 2500



EN 12 569
CERTIFICATE

Operating temperature: -196 °C ~ 550 °C

Connection into piping: Flanged, welded ends, threaded ends, combined execution



DESCRIPTION

C09 4 swing check valves are automatic check valves. They automatically prevent the reverse flow of the medium. The medium can flow in one direction only. These swing check valves are designed and manufactured to ensure maximum service life and reliability.

MATERIAL SPECIFICATION

C09 4 steel swing check valves are made from carbon, alloyed and stainless steels. The material type can be adjusted according to the customer's request to optimally suit the operating conditions.

APPLICATION

C09 4 steel swing check valves are mainly suitable for various chemicals and petrochemicals, liquids, gases and steam.

BASIC STANDARDS FOR DESIGN

Basic design

API 602, API 6D

Pressure-temperature rating

ASME B16.34

Testing

API 598, EN 12 266 - 1, 2

Face-to-face dimensions

ANSI B16.10

Dimensions of the welded ends

ANSI B16.25

Top Flange dimensions

None

Flange dimensions

ANSI B 16.5

Special

NACE MR-0175

SWING CHECK VALVES

TYPE C09 4

STRUCTURAL DESIGN

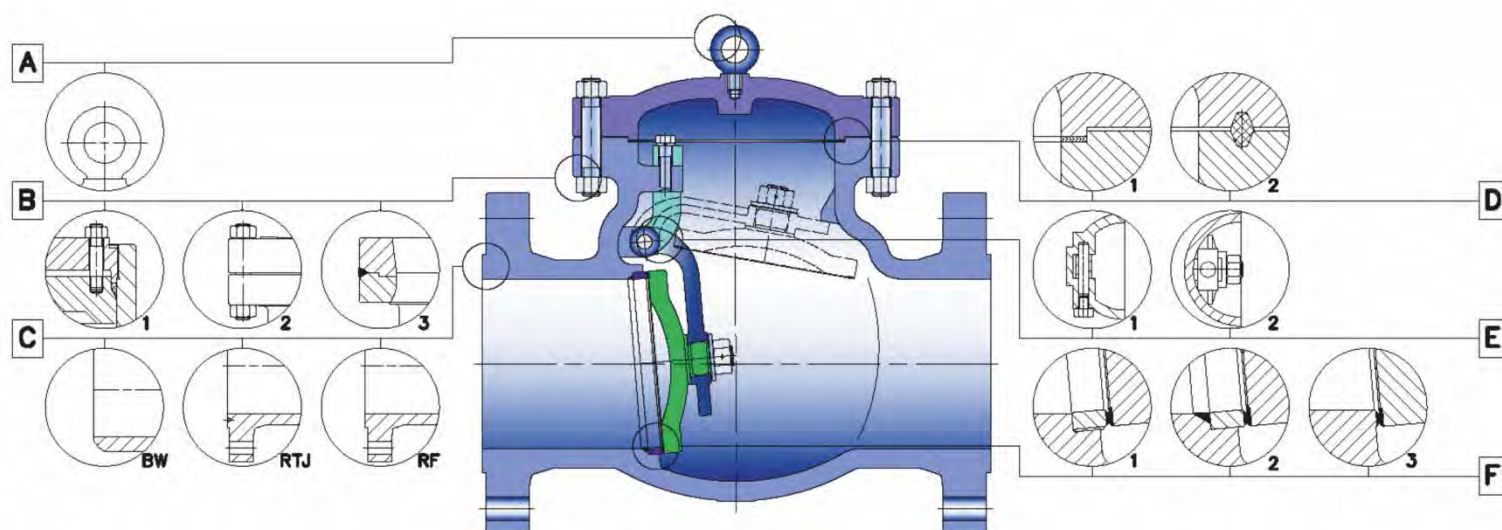

A - The handling eye bolt

- Class150 and 300 from NPS 8"
- Class600 from NPS 6"
- Class900 from NPS 4"
- Class1500,2500 by pressure seal bonnet

B – Bonnet execution

- the bonnet bolted to the body
- the bonnet welded to the body
- pressure seal bonnet is used for high pressures, temperatures and operation with cyclic changes of pressure

C – Connection to piping

- flanged
- welded
- threaded
- socket welding
- welded ends according to customer's requirements

D - Bonnet sealing

- Class150,300 - by gasket for male / female
- Class600,900 -by RTJ ring
- Class1500,2500 - by pressure seal bonnet

E – Pin placing

- the pin can be embedded in the special yoke, which is inserted into the body and fixed by bolt
- the pin can be inserted directly into the body. This option allows for lever connection with counter weight or damper

F- Seat execution

- the seat is screwed in the body
- the seat is inserted into the body and welded on
- the seat consists of a weld deposit on the body

SWING CHECK VALVES

TYPE C09 4

MATERIAL SPECIFICATION - CAST

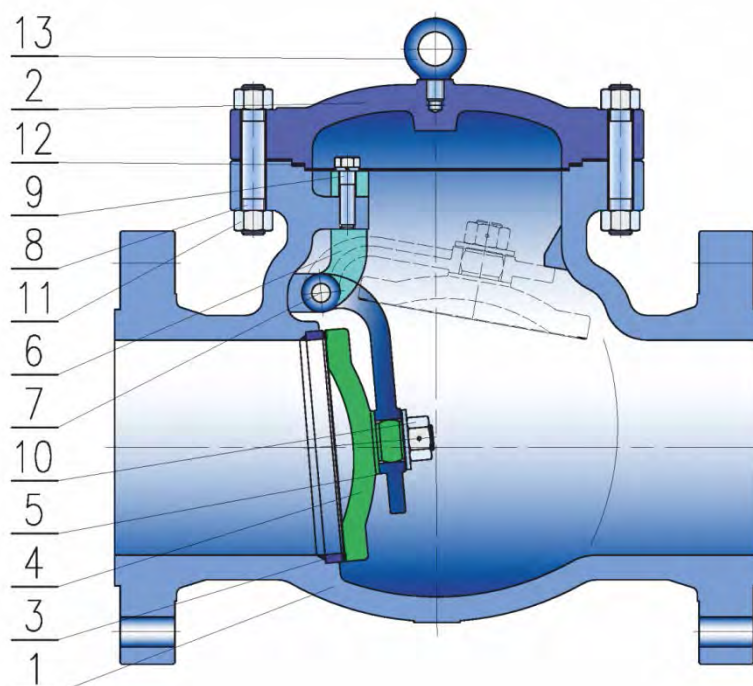

Pos.	Designation	WCB	LCC	LCB	WC6	WC9	C5	C12	CF8	CF8M
1	Body	A216 WCB	A352 LCC	A352 LCB	A217 WC6	A217 WC9	A217 C5	A217 C12	A351 CF8	A351 CF8M
2	Bonnet	A216 WCB	A352 LCC	A352 LCB	A217 WC6	A217 WC9	A217 C5	A217 C12	A351 CF8	A351 CF8M
3	Seat	A105 + overlay	A350 LF2 + overlay	A350 LF2 + overlay	A182 F5 + overlay	A182 F5 + overlay	A182 F5 + overlay	A182 F5 + overlay	A182 F304 + overlay	A182 F316 + overlay
4	Disc	A216 WCB + overlay	A352 LCC + overlay	A352 LCB + overlay	A217 WC6 + overlay	A217 WC9 + overlay	A217 C5 + overlay	A217 C12 + overlay	A351 CF8 + overlay	A351 CF8M + overlay
5	Hinge	A216 WCB	A352 LCC	A352 LCB	A217 WC6	A217 WC9	A217 C5	A217 C12	A351 CF8	A351 CF8M
6	Yoke	A216 WCB	A352 LCC	A352 LCB	A217 WC6	A217 WC9	A217 C5	A217 C12	A351 CF8	A351 CF8M
7	Pin	A182 F6a	A182 F6a	A182 F6a	A182 F6a	A182 F6a	A182 F6a	A182 F6a	A182 F304	A182 F316
8	Bolt	A193 B7	A320 L7	A320 L7	A193 B16	A193 B16	A193 B16	A193 B16	A193 B8	A193 B8M
9	Bolt	A193 B7	A320 L7	A320 L7	A193 B16	A193 B16	A193 B16	A193 B16	A193 B8	A193 B8M
10	Nut	A194 2H	A194 4	A194 4	A194 B8M	A194 B8M	A194 B8M	A194 B8M	A194 8	A194 8M
11	Nut	A194 2H	A194 4	A194 4	A194 B8M	A194 B8M	A194 B8M	A194 B8M	A194 8	A194 8M
12	Gasket	304 + graphite	304 + graphite	304 + graphite	304 + graphite	304 + graphite	304 + graphite	304 + graphite	304 + graphite	316 + graphite
13	Eye Bolt	A181	A181	A181	A181	A181	A181	A181	A181	A181

SWING CHECK VALVES

TYPE C09 4

TRIM SPECIFICATION

TRIM No.	Disc material	Seat material	Pin material
1	overlay 13Cr	overlay 13Cr	A 182 F6a
5	overlay Stellite 6	overlay Stellite	A 182 F6a
8	overlay 13Cr	overlay Stellite	A 182 F6a
9	overlay Monel	overlay Stellite	Monel
10	overlay 316	overlay 316	A 182 F316

MATERIAL SPECIFICATION - FORGED

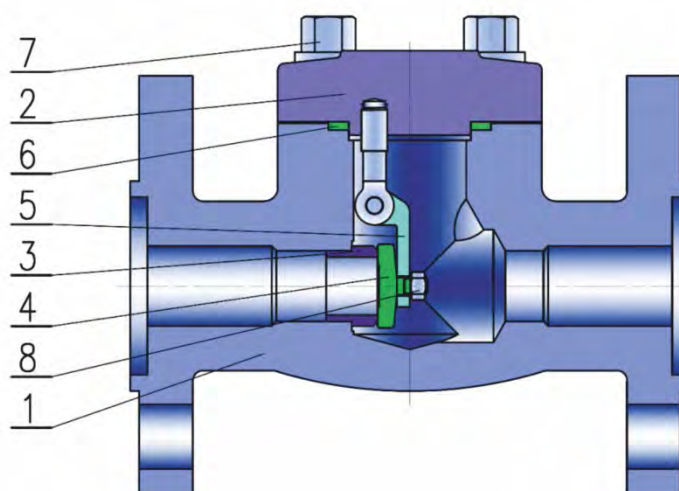

Pos.	Designation	A350 LF2	A105	A182 F5	A182 F9	A182 F304	A182 F316
1	Body	A350 LF2	A105	A182 F5	A182 F9	A182 F304	A182 F316
2	Bonnet	A350 LF2	A105	A182 F5	A182 F9	A182 F304	A182 F316
3	Seat	A350 LF2 + overlay	A105 + overlay	A182 F5 + overlay	A182 F9 + overlay	A182 F304 + overlay	A182 F316 + overlay
4	Disc	A350 LF2 + overlay	A105 + overlay	A182 F5 + overlay	A182 F9 + overlay	A182 F304 + overlay	A182 F316 + overlay
5	Yoke	A350 LF2	A105	A182 F5	A182 F9	A182 F304	A182 F316
6	Gasket	graphite, 304 + graphite, 316 + graphite					
7	Bolt	A320 L7	A193 B7	A193 B16	A193 B16	A193 B8	A193 B8M
8	Nut	A194 4	A194 2H	A194 2H	A194 2H	A194 8	A194 8M

SWING CHECK VALVES

TYPE C09 4

DIMENSIONS - CAST

CLASS 150 - 300

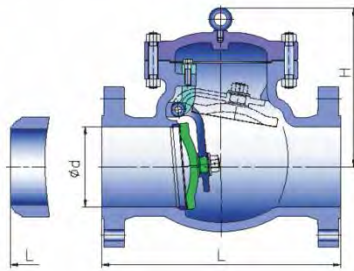

CLASS 600 - 900

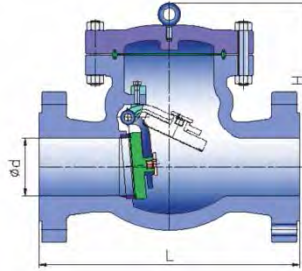

CLASS 1500 - 2500

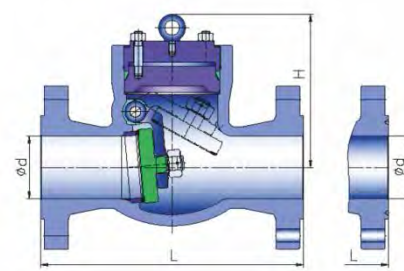

Diameter		CLASS 150						CLASS 300						CLASS 600						CLASS 900					
		Dimension (MM)						Dimension (MM)						Dimension (MM)						Dimension (MM)					
NPS	DN	L			d	H	(KG)	L			d	H	(KG)	L			h	H	(KG)	L			h	H	(KG)
		1/RF	1/RTJ	2				1/RF	1/RTJ	2				1/RF	1/RTJ	2				1/RF	1/RTJ	2			
2	50	203	216	203	51	132	16	267	283	267	51	144	21	292	295	292	51	170	28	368	371	368	51	200	48
2 1/2	65	216	229	216	64	147	21	292	308	292	64	169	36	330	333	330	64	178	40	381	384	381	64	220	75
3	80	241	254	241	76	176	28	318	334	318	76	210	41	356	359	356	76	246	68	419	422	419	76	280	95
4	100	292	305	292	102	198	46	356	372	356	102	260	62	432	435	432	102	290	117	457	460	457	102	320	135
5	125	330	343	330	127	255	59	400	416	400	127	295	81	508	511	508	127	320	155	559	562	559	127	360	200
6	150	356	368	356	152	320	69	445	461	445	152	326	131	559	562	559	152	360	192	610	613	610	152	400	264
8	200	495	508	495	203	380	132	533	549	533	203	380	191	660	663	660	203	430	340	737	740	737	203	480	424
10	250	622	635	622	254	440	219	622	638	622	254	440	298	787	790	787	254	502	515	838	841	838	254	560	730
12	300	698	711	698	305	480	323	711	727	711	305	520	452	838	841	838	305	554	750	965	968	965	305	632	1070
14	350	787	800	787	337	530	382	838	854	838	337	540	642	889	892	889	337	595	890	1029	1039	1029	322	680	1180
16	400	864	876	864	387	580	562	864	880	864	387	588	852	991	994	991	387	680	1303	1130	1140	1130	373	780	1790
18	450	978	991	978	438	618	632	978	994	978	438	670	1032	1092	1095	1092	438	778	1800	1219	1232	1219	423	880	2500
20	500	978	991	978	489	657	772	1016	1032	1016	489	720	1332	1194	1200	1194	489	970	2150	1321	1334	1321	471	1050	3080
24	600	1295	1308	1295	591	760	962	1346	1358	1346	591	850	1952	1397	1407	1397	591	1100	3200	1549	1568	1549	522	1200	4600
26	650	1295	-	1295	633	840	1252	1356	1381	1356	633	920	2302	-	-	-	-	-	-	-	-	-	-	-	-
28	700	1448	-	1448	684	920	1580	1499	1524	1499	684	1150	2600	1600	1613	1600	684	982	3100	-	-	-	-	-	-
30	750	1524	-	1524	735	980	1952	1594	1619	1594	735	1260	3202	-	-	-	-	-	-	-	-	-	-	-	-
32	800	1676	-	1676	779	760	1965	1778	1806	1778	779	1200	3500	1778	1794	1778	779	1189	4200	-	-	-	-	-	-
36	900	1956	-	1956	876	805	2300	2083	2109	2083	876	1388	3689	2083	2099	2083	876	1260	5200	-	-	-	-	-	-
40	1000	2150	-	2150	976	870	2700	2250	-	2250	976	1400	4100	2250	-	2250	976	1360	6300	-	-	-	-	-	-

Diameter		CLASS 1500						CLASS 2500					
		Dimension(MM)						Dimension(MM)					
NPS	DN	L			D	H	(KG)	L			D	H	(KG)
		1/RF	1/RTJ	2				1/RF	1/RTJ	2			
2	50	368	371	368	51	210	48	451	454	451	42	230	68
2 1/2	65	419	422	419	64	240	75	508	511	508	52	260	100
3	80	470	473	470	76	303	120	578	584	578	62	330	165
4	100	546	549	546	102	340	180	673	683	673	87	370	260
5	125	673	676	673	127	380	294	794	807	794	96	410	440
6	150	705	711	705	144	430	385	914	927	914	131	460	580
8	200	832	842	832	192	500	634	1022	1038	1022	179	530	970
10	250	991	1001	991	239	590	1140	1270	1292	1270	223	620	1700
12	300	1130	1146	1130	287	660	1650	1422	1444	1422	265	690	2600
14	350	1257	1276	1257	315	710	2000	-	-	-	-	-	-
16	400	1384	1406	1384	360	820	2700	-	-	-	-	-	-

SWING CHECK VALVES

TYPE C09 4

DIMENSIONS - FORGED

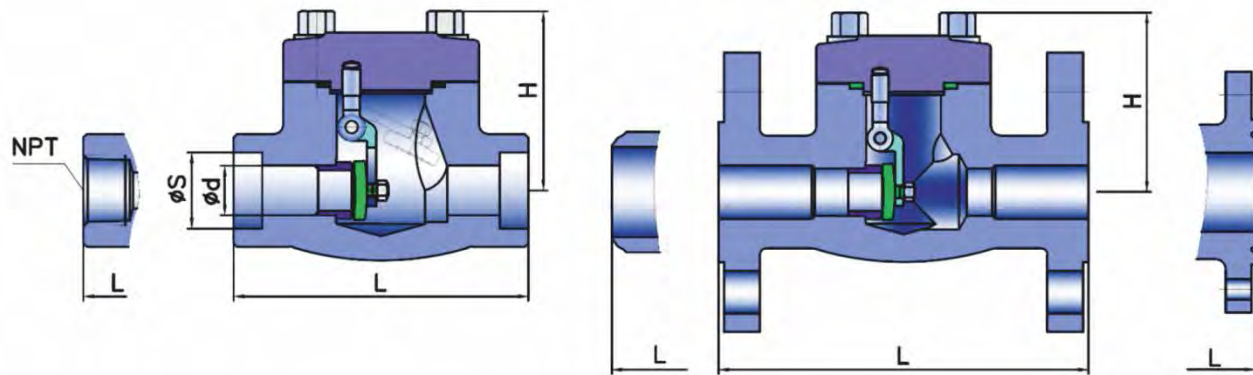

Diameter		CLASS 900,1500									CLASS 2500								
NPS	DN	L					d	S	H	(KG)	L					d	S	H	(KG)
		1/RF	1/RTJ	2	3	4					1/RF	1/RTJ	2	3	4				
1/4	6	216	-	216	79	79	3,2	14,2	166	2,5	264	-	264	79	79	3,2	14,2	166	3
3/8	10	216	-	216	79	79	5,9	17,6	166	3	264	-	264	79	79	5,9	17,6	166	3
1/2	15	216	216	216	79	79	9,5	21,8	166	4	264	263	264	79	79	9,5	21,8	166	5
3/4	20	229	229	229	92	92	12,7	27,1	169	5	273	273	273	92	92	12,7	27,1	169	6
1	25	254	254	254	111	111	17,5	33,8	193	9	308	304	308	111	111	17,5	33,8	193	11
1 1/2	40	305	305	305	152	152	28,6	48,7	246	13	384	384	384	152	152	28,6	48,7	246	15
2	50	368	371	368	172	172	36,5	61,1	283	16	451	454	451	172	172	36,5	61,1	283	18

Diameter		CLASS 600									CLASS 800								
NPS	DN	L					d	S	H	(KG)	L					d	S	H	(KG)
		1/RF	1/RTJ	2	3	4					1/RF	1/RTJ	2	3	4				
1/4	6	165	-	165	79	79	3,2	14,2	61	2,5	-	-	-	79	79	3,2	14,2	166	2
3/8	10	165	-	165	79	79	5,9	17,6	61	3	-	-	-	79	79	5,9	17,6	166	2,5
1/2	15	165	165	165	79	79	9,5	21,8	61	4	-	-	-	79	79	9,5	21,8	166	3,5
3/4	20	190	190	190	92	92	12,7	27,1	78	6	-	-	-	92	92	12,7	27,1	169	4,5
1	25	216	216	216	111	111	17,5	33,8	84	10	-	-	-	111	111	17,5	33,8	193	8
1 1/2	40	241	241	241	152	152	28,6	48,7	118	16	-	-	-	152	152	28,6	48,7	246	12
2	50	292	295	292	172	172	36,5	61,1	132	25	-	-	-	172	172	36,5	61,1	283	14,5

SWING CHECK VALVES

TYPE C09 4

TYPE DESIGNATION

C09 4 C/D E M₁ Class/S
C
CONNECTION INTO PIPE

- 1 Flanged
- 2 Welded ends
- 3 Threaded
- 4 Socket welding
- 8 Combined

M₁
BODY MATERIAL

- 0 Stainless steel
- 2 Cast alloy steel
- 3 Forged alloy steel
- 4 Forged carbon steel
- 5 Cast carbon steel
- L Carbon steel for low
- T temperatures

D
FLANGE FACING
ANSI B 16.5

- | | |
|------------|-------------------|
| PFF | Flat sealing face |
| RF | Raised face |
| LTF | Large tongue |
| STF | Small tongue |
| LGF | Large groove |
| SGF | Small groove |
| LMF | Large male |
| SMF | Small male |
| LFF | Large female |
| SFF | Small female |
| RTJ | Ring joint |

E
CONTROL

- 7 Automatic

S
SPECIAL EXECUTION

- | | |
|-----------|------------------------|
| L | With lever and counter |
| B | Bypass |
| As | Antistatic execution |





Range DN: 100 ~ 1400
NPS: 4" ~ 56"



PED 97/23/EC
PED 2014/68/EU



TR TS 10/11,
12/11, 32/11



Range PN: 6 ~ 63
Class: 150 ~ 300

Operating temperature: Depending on the material of seat ring.
Connection into piping: Flanged, welded ends, threaded ends, combined execution

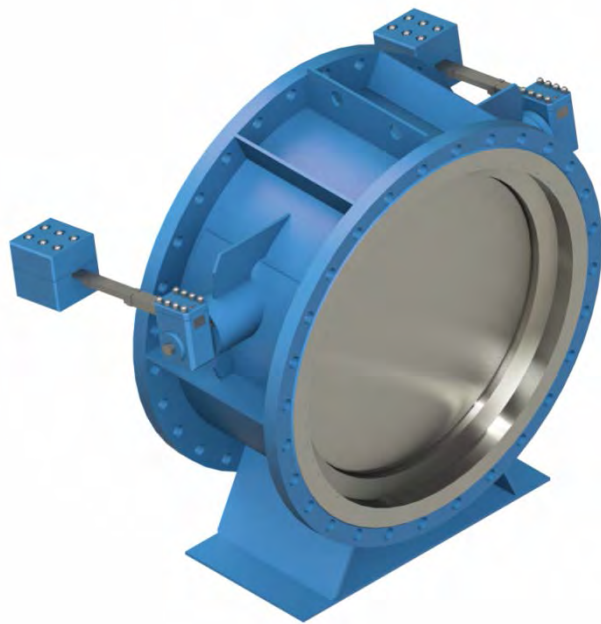

DESCRIPTION

C09 5 swing check valves are automatic, fast closing check valves. They automatically prevent the reverse flow of the medium. The medium can flow in one direction only. These swing check valves are designed and manufactured to ensure maximum service life and reliability.

MATERIAL SPECIFICATION

C09 5 swing check valves are made from carbon, alloyed and stainless steels. The material type can be adjusted according to the customer's request to optimally suit the operating conditions.

APPLICATION

C09 5 swing check valves are mainly suitable for various chemicals and petrochemicals, liquids, gases and steam.

BASIC STANDARDS FOR DESIGN

Basic design

API 602, API 6D

Pressure-temperature rating

ASME B16.34, EN 12 516 - 1

Testing

API 598, EN 12 266 - 1, 2

Face-to-face dimensions

ANSI B16.10, EN 558, EN 12 982

Dimensions of the welded ends

ANSI B16.25, EN 12 627

Top Flange dimensions

None

Flange dimensions

ANSI B 16.5, EN 1092 - 1

Special

NACE MR-0175

SWING CHECK VALVES

TYPE C09 5

MATERIAL SPECIFICATION

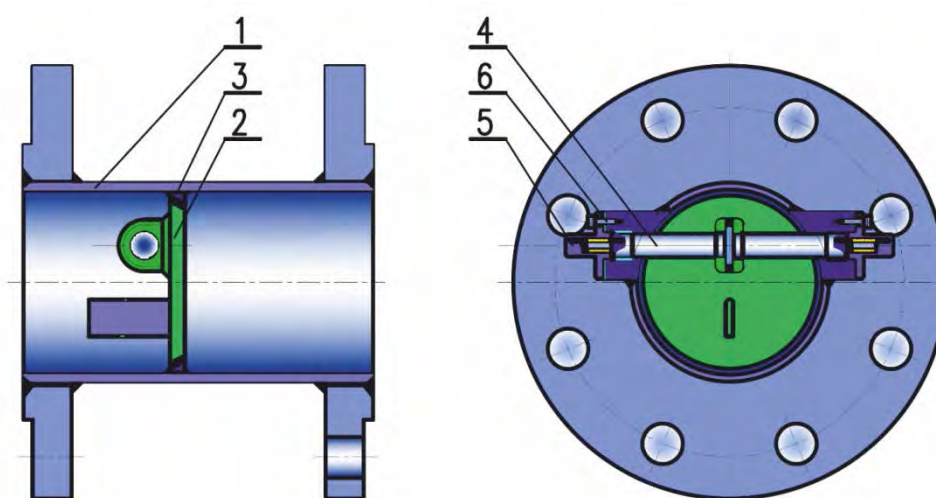

ITEM	NAME	MATERIAL
1	BODY	P265 GH, P355 NL1, P355 NH, S355 J2G3, S235 JRG2, 14MoV6-3, St52-3, 1.4541
2	DISC	P265 GH, P355 NL1, P355 NH, S355 J2G3, S235 JRG2, 14MoV6-3, St52-3, 1.4541, + surfacing
3	SEAT	X12Cr13 QT, 1.4541, + surfacing or seat ring (EPDM, NBR, VITON, GRAPHITE)
4	PIN	1.4057+QT, X10Cr13, X20Cr20MoV12-1
5	BONNET	S355 J2G3 (S235 JRG2)
6	BOLT	8.8, A2-70, 25CrMo4, 42CrMo4, 21CrMoV5-7

MATERIAL SPECIFICATION

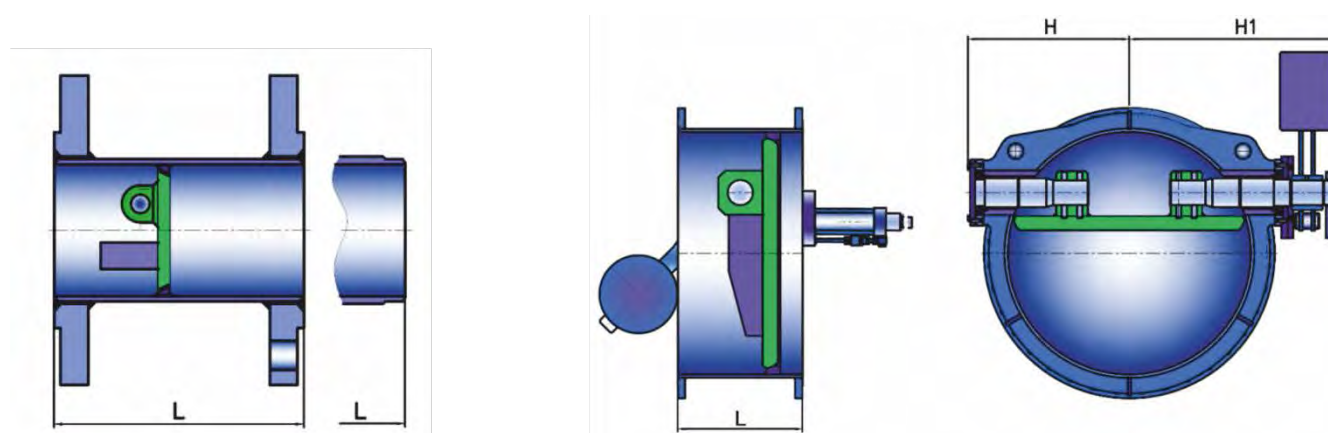

SWING CHECK VALVES

TYPE C09 5

DIMENSIONS

DN	PN 6				PN 10				PN 16				PN 25			
	L	H	H1	Mass (kg)	L	H	H1	Mass (kg)	L	H	H1	Mass (kg)	L	H	H1	Mass (kg)
100	190	120	265	35	190	120	265	44	190	120	265	44	190	120	265	50
125	200	135	267	40	200	135	274	45	200	135	274	45	200	135	274	58
150	210	150	280	49	210	150	280	49	210	150	280	49	210	150	280	60
200	230	176	290	55	230	176	286	58	230	176	286	58	230	176	286	65
250	250	230	320	58	250	230	320	60	250	230	320	70	250	235	330	85
300	270	250	340	68	270	250	340	90	270	250	340	93	270	245	370	111
350	290	270	360	108	290	270	360	130	290	270	360	150	290	270	387	181
400	310	276	380	148	310	292	363	160	310	292	363	190	310	300	440	230
500	350	450	590	240	350	440	600	230	350	440	600	260	350	407	615	300
600	390	495	675	320	390	495	675	360	390	495	675	390	390	500	690	450
700	430	538	720	515	430	538	720	530	430	538	720	570	430	550	750	670
800	470	572	814	695	470	572	814	710	470	572	814	740	470	572	914	1060
1000	550	687	890	1060	550	687	890	1205	550	687	890	1315	550	700	950	1520
1200	630	780	1010	1320	630	830	1100	1900	630	830	1100	2300	630	840	1150	2500
1400	710	970	1250	2450	710	970	1250	2600	710	970	1250	3100	-	-	-	-

DN	PN 40				PN 63				NPS	CLASS 150				CLASS 300			
	L	H	H1	Mass (kg)	L	H	H1	Mass (kg)		L	H	H1	Mass (kg)	L	H	H1	Mass (kg)
100	190	120	250	55	190	130	260	60	4	292	120	265	49	356	120	250	57
125	200	135	280	65	200	145	290	68	5	324	135	267	55	406	135	280	68
150	210	150	280	75	210	150	295	80	6	356	150	280	58	445	150	280	79
200	230	180	280	110	230	240	343	125	8	495	176	280	67	533	180	280	117
250	250	240	340	165	250	260	380	160	10	622	230	320	93	622	240	340	167
300	270	260	400	200	270	315	405	240	12	698	270	370	125	711	260	400	216
350	290	315	450	280	290	340	464	350	14	787	300	435	192	838	315	450	326
400	310	340	515	400	310	385	516	450	16	914	315	470	244	864	340	515	426
500	350	445	580	590	350	435	570	700	20	978	440	600	338	1016	445	580	629
600	390	510	684	810	390	520	690	980	24	1295	495	680	523	1346	510	684	860
700	430	550	780	1150	430	560	790	1310	28	1448	540	720	740	1499	550	780	1255
800	470	670	890	1490	470	680	910	1680	32	1600	572	814	965	1651	670	890	1628
1000	550	720	970	2205	550	750	1020	2408	40	1906	687	890	1640	1956	720	970	2388
1200	630	850	1160	2950	-	-	-	-	48	2212	830	1100	2760	2260	850	1160	3450
1400	-	-	-	-	-	-	-	-	56	2518	970	1250	3725	-	-	-	-

 TYPE DESIGNATION

C09 5 C/D E M₁/M₂ PN or Class/S
C CONNECTION INTO PIPE

- 1 Flanged
- 2 Welded
- 8 Combined

M₁ BODY / DISC MATERIAL

- 0 Stainless steel
- 3 Forged alloy steel
- 4 Forged carbon steel
- LT Carbon steel for low temperatures

M₂ SEALING ELEMENT MATERIAL

- E EPDM
- N NBR
- HN HNBR
- P CR
- S WMQ
- T PTFE
- V VITON

E CONTROL

- 7 Automatic
- 6 Hydraulic actuator

D FLANGE FACING
EN 1092-1

- A Flat face
- B Raised face
- C Tongue face
- D Groove face
- E Spigot
- F Recess
- G O - ring recess
- H O - ring groove

ANSI B16.5

- PFF Flat sealing face
- RF Raised face
- LTF Large tongue
- STF Small tongue
- LGF Large groove
- SGF Small groove
- LMF Large male
- SMF Small male
- LFF Large female
- SFF Small female
- RTJ Ring joint

S SPECIAL EXECUTION

- L With lever and counterweight
- H With hydraulic shaft
- S With spring mechanism





Range DN: 15 ~ 1000



PED 97/23/EC
PED 2014/68/EU



TR TS 10/11,
12/11, 32/11



Range PN: 10 ~ 100



EN 12 569
CERTIFICATE

Operating temperature: -196 °C ~ 550 °C

Connection into piping: Flanged, welded ends, threaded ends, combined execution



DESCRIPTION

L10 swing check valves are automatic check valves. They automatically prevent the reverse flow of the medium. The medium can flow in one direction only. These swing check valves are designed and manufactured to ensure maximum service life and reliability.

MATERIAL SPECIFICATION

L10 swing check valves are made from carbon, alloy and stainless steels. The material type can be adjusted according to the customer's request to optimally suit the operating conditions.

APPLICATION

L10 swing check valves are suitable for various liquids, gases and steam.

BASIC STANDARDS FOR DESIGN

Basic design

EN 14 341

Pressure-temperature rating

EN 12 516 - 1

Testing

EN 12 266 - 1, 2

Face-to-face dimensions

EN 558, EN 12 982

Dimensions of the welded ends

EN 12 627

Top Flange dimensions

None

Flange dimensions

EN 1092 - 1

Special

NACE MR-0175

SWING CHECK VALVES

TYPE L10

STRUCTURAL DESIGN

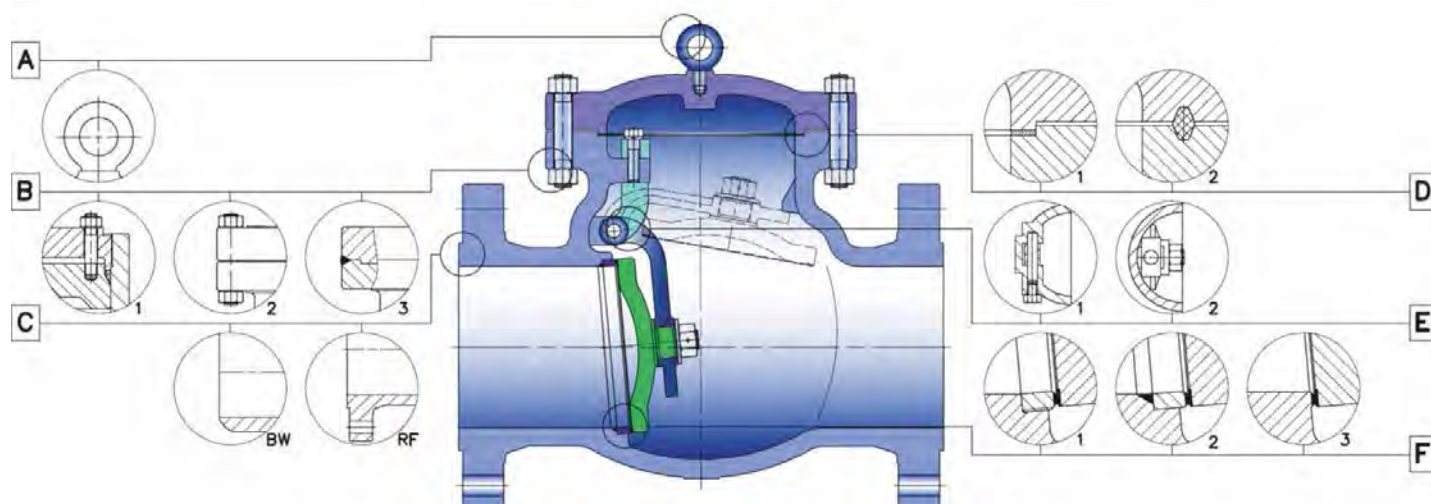

A – The handling eye bolt

- To PN 63 from DN 200
- PN 100 from DN 150

B - Bonnet execution

- the bonnet bolted to the body
- the bonnet welded to the body

C - Connection to piping

- flanged- FLG
- welded – BW
- with welded ends according to the customer's requirements

D - Bonnet sealing

- male / female
- RTJ ring

E - Pin placing

- the pin can be embedded in the special yoke, which is inserted into the body and fixed by a bolt
- the pin can be inserted directly into the body. This option allows for lever connection with counterweight or damper

F - Seat execution

- the seat is screwed into the body
- the seat is inserted in the body and welded on
- the seat consists of a weld deposit on the body

MATERIAL SPECIFICATION - FORGED

Pos.	Designation	A350 LF2	A105	A182 F5	A182 F9	A182 F304	A182 F316
1	Body	A350 LF2	A105	A182 F5	A182 F9	A182 F304	A182 F316
2	Bonnet	A350 LF2	A105	A182 F5	A182 F9	A182 F304	A182 F316
3	Seat	A350 LF2 + overlay	A105 + overlay	A182 F5 + overlay	A182 F9 + overlay	A182 F304 + overlay	A182 F316 + overlay
4	Disc	A350 LF2 + overlay	A105 + overlay	A182 F5 + overlay	A182 F9 + overlay	A182 F304 + overlay	A182 F316 + overlay
5	Yoke	A350 LF2	A105	A182 F5	A182 F9	A182 F304	A182 F316
6	Gasket	graphite, 304 + graphite, 316 + graphite					
7	Bolt	A320 L7	A193 B7	A193 B16	A193 B16	A193 B8	A193 B8M
8	Nut	A194 4	A194 2H	A194 2H	A194 2H	A194 8	A194 8M

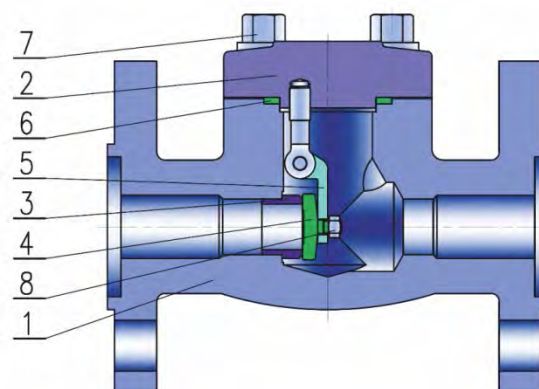

SWING CHECK VALVES

TYPE L10

MATERIAL SPECIFICATION - CAST

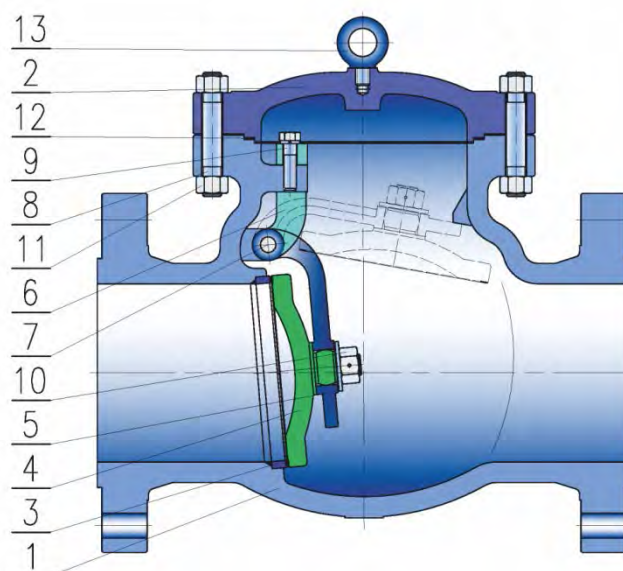

Pos.	Designation	GP240GH (1.0619)	G17CrMo5-5 (1.7357)	GS12CrMo 19-5 (1.7363)	GX12CrMo 10-1 (1.7389)	G17Mn5 (1.1131)	G20Mn5 (1.6220)	GX5CrNi19-10 (1.4308)	GX5CrNiMo19-11-2 (1.4408)	
1	Body	GP240GH	G17CrMo5-5	GS12CrMo 19-5	GX12CrMo 10-1	G17Mn5	G20Mn5	GX5CrNi19-10	GX5CrNiMo19-11-2	
2	Bonnet	GP240GH	G17CrMo5-5	GS12CrMo 19-5	GX12CrMo 10-1	G17Mn5	G20Mn5	GX5CrNi19-10	GX5CrNiMo19-11-2	
3	Seat	St 45.8 + overlay	13CrMo4-5 + overlay	X11CrMo5 + overlay	X11CrMo 9-1 + overlay	P355NH + overlay	P355 NL1 + overlay	X5CrNi18-10 + overlay	X5CrNiMo17-12-2 + overlay	
4	Disc	GP240GH + overlay	G17CrMo5-5 + overlay	GS12CrMo 19-5 + overlay	GX12CrMo 10-1 + overlay	G17Mn5 + overlay	G20Mn5 + overlay	GX5CrNi19-10 + overlay	GX5CrNiMo19-11-2 + overlay	
5	Hinge	GP240GH	G17CrMo5-5	GS12CrMo 19-5	GX12CrMo 10-1	GX12CrMo 10-1	G20Mn5	GX5CrNi19-10	GX5CrNiMo19-11-2	
6	Yoke	GP240GH	G17CrMo5-5	GS12CrMo 19-5	GX12CrMo 10-1	GX12CrMo 10-1	G20Mn5	GX5CrNi19-10	GX5CrNiMo19-11-2	
7	Pin	X12Cr13	X12Cr13	X12Cr13	X12Cr13	X12Cr13	X12Cr13	X5CrNi18-10	X5CrNiMo17-12-2	
8	Bolt	42CrMo4	A193 B16	A193 B16	A193 B16	42CrMo4	26CrMo4	A193 B8, A4-70	A193 B8M, A4-70	
9	Bolt	42CrMo4	A193 B16	A193 B16	A193 B16	42CrMo4	26CrMo4	A193 B8, A4-70	A193 B8M, A4-70	
10	Nut	25CrMo4	A194 7	A194 7	A194 7	25CrMo4	26CrMo4	A194 8, A4-70	A194 8M, A4-70	
11	Nut	25CrMo4	A194 7	A194 7	A194 7	25CrMo4	26CrMo4	A194 8, A4-70	A194 8M, A4-70	
12	Gasket	graphite, 304 + graphite, 316 + graphite								
13	Eye bolt	carbon steel							stainless steel	

SWING CHECK VALVES

TYPE L10

MATERIAL SPECIFICATION - CAST

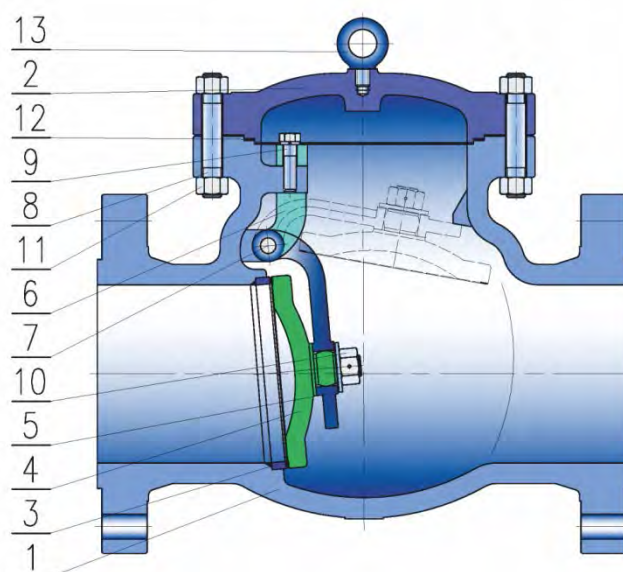

Pos.	Designation	WCB	LCC	LCB	WC6	WC9	C5	C12	CF8	CF8M	
1	Body	A216 WCB	A352 LCC	A352 LCB	A217 WC6	A217 WC9	A217 C5	A217 C12	A351 CF8	A351 CF8M	
2	Bonnet	A216 WCB	A352 LCC	A352 LCB	A217 WC6	A217 WC9	A217 C5	A217 C12	A351 CF8	A351 CF8M	
3	Seat	A105 +overlay	A350 LF2 + overlay	A350 LF2 + overlay	A182 F5 +overlay	A182 F5 +overlay	A182 F5 +overlay	A182 F5 +overlay	A182 F304 +overlay	A182 F316 +overlay	
4	Disc	A216 WCB + overlay	A352 LCC + overlay	A352 LCB + overlay	A217 WC6 + overlay	A217 WC9 + overlay	A217 C5 + overlay	A217 C5 + overlay	A351 CF8 + overlay	A351 CF8M + overlay	
5	Hinge	A216 WCB	A352 LCC	A352 LCB	A217 WC6	A217 WC9	A217 C5	A217 C12	A351 CF8	A351 CF8M	
6	Yoke	A216 WCB	A352 LCC	A352 LCB	A217 WC6	A217 WC9	A217 C5	A217 C12	A351 CF8	A351 CF8M	
7	Pin	A182 F6a	A182 F6a	A182 F6a	A182 F6a	A182 F6a	A182 F6a	A182 F6a	A182 F304	A182 F316	
8	Bolt	A193 B7	A320 L7	A320 L7	A193 B16	A193 B16	A193 B16	A193 B16	A193 B8	A193 B8M	
9	Bolt	A193 B7	A320 L7	A320 L7	A193 B16	A193 B16	A193 B16	A193 B16	A193 B8	A193 B8M	
10	Nut	A194 2H	A194 4	A194 4	A194 2H	A194 2H	A194 2H	A194 2H	A194 8	A194 8M	
11	Nut	A194 2H	A194 4	A194 4	A194 2H	A194 2H	A194 2H	A194 2H	A194 8	A194 8M	
12	Gasket	graphite, 304 + graphite, 316 + graphite									
13	Eye bolt	carbon steel							stainless steel		

SWING CHECK VALVES

TYPE L10

DIMENSIONS

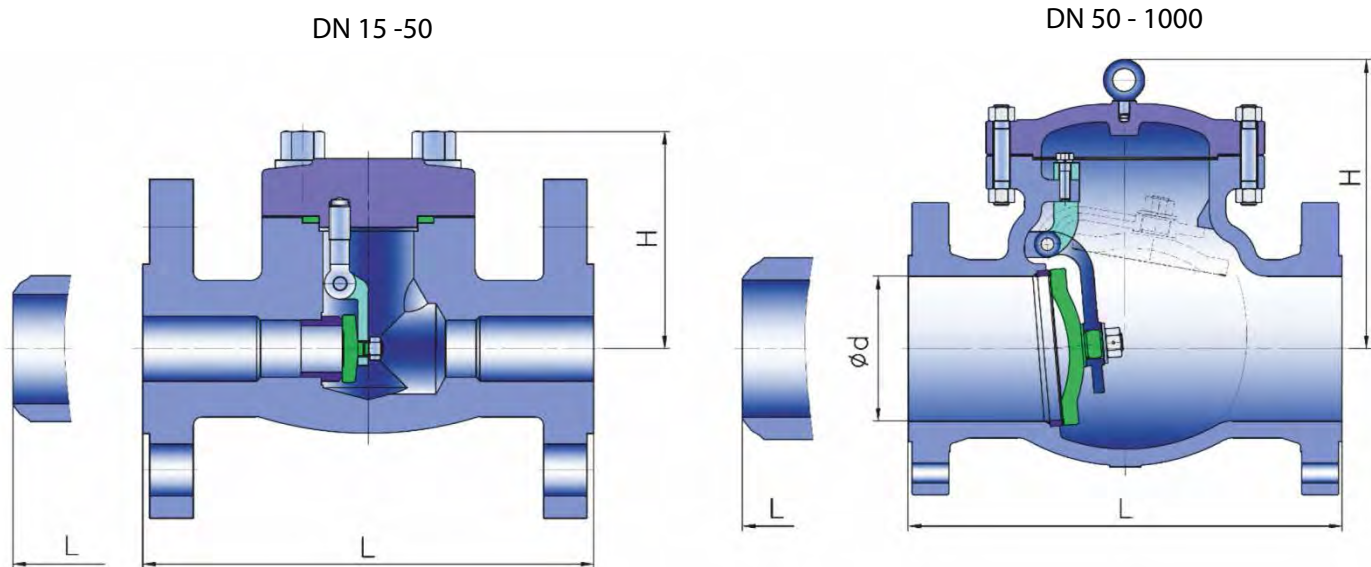

DN	PN 10, 16					PN 25					PN 40					PN 63					PN 100				
	L		D	H	(KG)	L		D	H	(KG)	L		D	H	(KG)	L		D	H	(KG)	L		D	H	(KG)
DN	1	2				1	2				1	2				1	2				1	2			
15	130	130	14	61	3,4	130	130	14	61	3,4	130	130	14	61	3,7	210	150	14	61	4,0	210	150	14	61	4,0
25	160	160	25	84	8,2	160	160	25	84	8,2	160	160	25	84	8,8	230	160	25	84	9,5	230	160	25	84	9,5
32	180	180	32	103	8,9	180	180	32	103	8,9	180	180	32	103	9,6	260	180	32	103	10,4	260	180	32	103	10,4
40	200	200	43.1	120	8	200	200	43.1	95	8	200	200	43.1	95	13	260	210	42.5	150	14	260	210	42	150	14
50	230	230	54.5	134	16	230	230	54.5	135	16	230	230	54.5	135	21	300	250	53.5	175	28	300	250	51	170	28
65	290	290	70.3	140	21	290	290	70.3	140	21	290	290	70.3	140	36	340	340	69.7	190	40	340	340	64	190	40
80	310	310	82.5	175	28	310	310	82.5	175	28	310	310	82.5	175	41	380	380	81.7	210	68	380	380	76	210	68
100	350	350	107.1	180	46	350	350	107.1	195	46	350	350	107.1	195	62	430	430	106.3	245	117	430	430	102	245	117
125	400	400	131.7	195	59	400	400	131.7	205	59	400	400	131.7	205	81	500	500	130.7	260	155	500	500	127	260	155
150	480	480	159.3	300	69	480	480	161.5	305	69	480	480	161.5	305	131	550	550	158.3	337	192	550	550	152	337	192
200	600	600	206.5	350	132	600	600	206.5	350	132	600	600	206.3	350	191	650	650	204.9	397	340	650	650	203	397	340
250	730	730	260.4	395	219	730	730	258.2	425	219	730	730	258.2	425	298	775	775	255.2	455	515	775	775	254	455	515
300	850	850	309.7	465	232	850	850	307.9	475	323	850	850	307.9	475	452	900	900	301.9	542	750	900	900	305	542	750
350	980	980	339.6	470	382	980	980	337.6	515	382	980	980	337.9	515	642	1025	1025	334.6	568	890	1025	1025	322	568	890
400	1100	1100	390	485	562	1100	1100	388.8	540	562	1100	1100	384.4	540	852	1150	1150	382.6	634	1303	1150	1150	373	643	1303
450	1200	1200	439	505	632	1200	1200	439.4	590	632	1200	1200	432.0	600	1032	1275	1275	423	680	1800	1275	1275	418	680	1800
500	1250	1250	492	565	772	1250	1250	488	640	772	1250	1250	479.6	640	1332	1400	1400	471	750	2150	1400	1400	471	750	2150
600	1450	1450	590	650	962	1450	1450	591	775	962	1450	1450	591	775	1952	1600	1600	586	852	3200	1600	1600	522	880	3200
700	1650	1650	691	700	1580	1650	1650	684	830	1580	1650	1650	684	830	2600	-	-	-	-	-	-	-	-	-	-
800	1850	1850	793	980	2540	1850	1850	785	980	2540	1850	1850	781	1270	3380	-	-	-	-	-	-	-	-	-	-
900	2050	2050	894	1377	3380	2050	2050	882	1377	3380	2050	2050	876	1510	5640	-	-	-	-	-	-	-	-	-	-
1000	2250	2250	996	1410	4815	2250	2250	981	1410	4815	2250	2250	978	1750	6150	-	-	-	-	-	-	-	-	-	-

SWING CHECK VALVES

TYPE L10

TYPE DESIGNATION

L10 C/D E M1 PN/S
C
CONNECTION INTO PIPE

- 1 Flanged
- 2 Welded ends
- 8 Combined

M₁
BODY MATERIAL

- 0 Stainless steel
- 2 Cast alloy steel
- 3 Forged alloy steel
- 4 Forged carbon steel
- 5 Cast carbon steel
- LT Carbon steel for low temperatures

D
FLANGE FACING
EN 1092 - 1

- A Flat face
- B Raised face
- C Tongue face
- D Groove face
- E Spigot
- F Recess

E
CONTROL

- 7 Automatic

S
SPECIAL EXECUTION

- B With bypass
- L With lever and counterweight





Range DN: 50 ~ 400



Range PN: 160 ~ 400



PED 97/23/EC
PED 2014/68/EU



TR TS 10/11,
12/11, 32/11



EN 12 569
CERTIFICATE



HIGH-PRESSURE
EXECUTION

Operating temperature: -196 °C ~ 550 °C

Connection into piping: Flanged, welded ends, threaded ends, combined execution

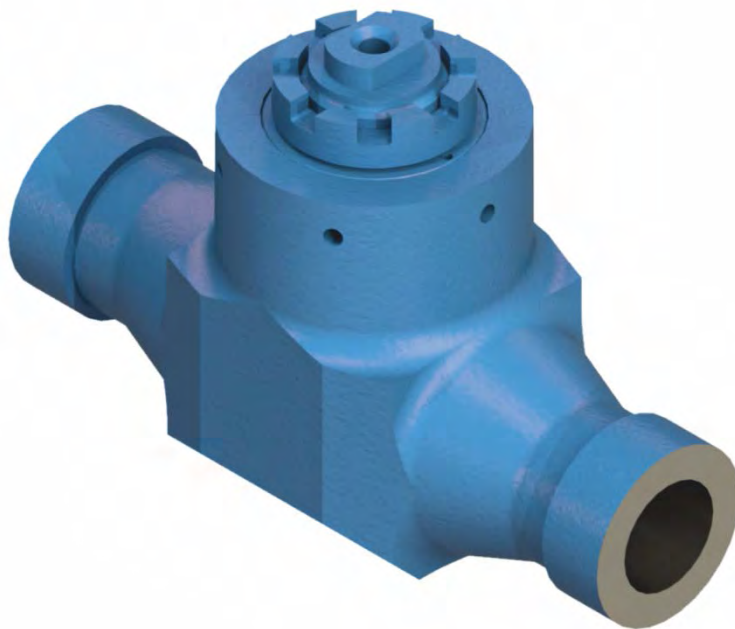

DESCRIPTION

L10 swing check valves are automatic check valves. They automatically prevent the reverse flow of the medium. The medium can flow in one direction only. These swing check valves are designed and manufactured to ensure maximum service life and reliability.

MATERIAL SPECIFICATION

L10 swing check valves are made from carbon, alloy and stainless steels. The material type can be adjusted according to the customer's request to optimally suit the operating conditions.

APPLICATION

L10 swing check valves are suitable for high-pressure various liquids, gases and steam.

BASIC STANDARDS FOR DESIGN

Basic design

EN 14 341

Pressure-temperature rating

EN 12 516 - 1

Testing

EN 12 266 - 1, 2

Face-to-face dimensions

EN 558, EN 12 982

Dimensions of the welded ends

EN 12 627

Top Flange dimensions

None

Flange dimensions

EN 1092 - 1

Special

NACE MR-0175

SWING CHECK VALVES

TYPE **L10**

MATERIAL SPECIFICATION

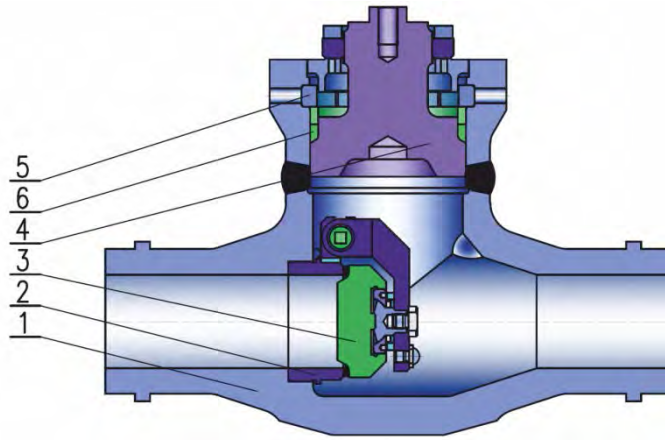

Pos.	Description	P250GH (1.0460)	P265GH (1.0425)	P285NH (1.0477)	16Mo3 (1.5415)	G20Mo5 (1.5419)	13CrMo4-5 (1.7335)	14MoV6-3 (1.7715)	10CrMo9-10 (1.7380)	X20CrMoV12-1 (1.4922)	X10CrMoVNb9-1 (1.4903)	X6CrNiTi18-10 (1.4541)
1	Body	P250GH (1.0460)	P265GH (1.0425)	P285NH (1.0477)	16Mo3 (1.5415)	G20Mo5 (1.5419)	13CrMo4-5 (1.7335)	14MoV6-3 (1.7715)	10CrMo9-10 (1.7380)	X20CrMoV12-1 (1.4922)	X10CrMoVNb9-1 (1.4903)	X6CrNiTi18-10 (1.4541)
2	Seat	P250GH (1.0460) + overlay	P265GH (1.0425) + overlay	P285NH (1.0477) + overlay	16Mo3 (1.5415) + overlay	G20Mo5 (1.5419) + overlay	13CrMo4-5 (1.7335) + overlay	14MoV6-3 (1.7715) + overlay	10CrMo9-10 (1.7380) + overlay	X20CrMoV12-1 (1.4922) + overlay	X10CrMoVNb9-1 (1.4903) + overlay	X6CrNiTi18-10 (1.4541) + overlay
3	Disc	P250GH (1.0460)	P265GH (1.0425) + overlay	P285NH (1.0477) + overlay	16Mo3 (1.5415) + overlay	G20Mo5 (1.5419) + overlay	13CrMo4-5 (1.7335) + overlay	14MoV6-3 (1.7715) + overlay	10CrMo9-10 (1.7380) + overlay	X20CrMoV12-1 (1.4922) + overlay	X10CrMoVNb9-1 (1.4903) + overlay	X6CrNiTi18-10 (1.4541) + overlay
4	Pressure sealing	P250GH (1.046)	P265GH (1.0425)	P285NH (1.0477)	16Mo3 (1.5415)	G20Mo5 (1.5419)	13CrMo4-5 (1.7335)	14MoV6-3 (1.7715)	10CrMo9-10 (1.7380)	X20CrMoV12-1 (1.4922)	X10CrMoVNb9-1 (1.4903)	X6CrNiTi18-10 (1.4541)
5	Split ring	P250GH (1.0460)	P265GH (1.0425)	P285NH (1.0477)	16Mo3 (1.5415)	G20Mo5 (1.5419)	13CrMo4-5 (1.7335)	14MoV6-3 (1.7715)	10CrMo9-10 (1.7380)	X20CrMoV12-1 (1.4922)	X10CrMoVNb9-1 (1.4903)	X6CrNiTi18-10 (1.4541)
6	Gasket	graphite										

DIMENSIONS

DN	PN 160 (CLASS 600)					PN 250 (CLASS 900)				
	L		d	H	(KG)	L		D	H	(KG)
	1	2				1	2			
50/40	270	270	40	160	51	310	310	40	160	55
50/50	300	300	50	160	55	350	350	50	160	58
65/50	360	360	50	180	63	425	425	50	180	71
80/75	390	390	75	252	108	470	470	75	252	120
100/75	450	450	75	252	110	550	550	75	252	142
125/110	525	525	110	320	262	650	650	110	320	298
150/110	600	600	110	320	283	750	750	110	320	301
200/150	750	750	150	390	519	950	950	150	390	644
250/200	900	900	200	490	1017	1150	1150	200	490	1218
300/250	1050	1050	250	770	3443	-	-	-	-	-

DN	PN 320 (CLASS 1500)					PN 400 (CLASS 2500)			
	L	d	H	(KG)	L	d	H	(KG)	
									2
50/40	320	40	160	81	320	40	160	87	
50/50	360	50	160	90	360	50	160	98	
65/50	360	50	180	96	360	50	180	105	
65/55	360	55	180	95	360	55	180	104	
80/75	450	75	252	206	450	75	252	220	
100/75	450	75	252	202	450	75	252	217	
125/110	500	110	320	255	500	110	320	269	
150/110	550	110	320	258	550	110	320	274	
175/125	650	125	390	552	650	125	390	588	
175/150	650	150	390	841	650	150	390	873	
200/150	650	150	390	850	650	150	390	882	
225/175	700	175	450	1603	700	175	450	1724	
250/200	800	200	490	2020	800	200	490	2145	
275/200	850	200	490	2034	850	200	490	2160	
250/225	800	225	592	2705	800	225	592	2904	
275/225	850	225	592	2717	850	225	592	2925	
300/225	900	225	592	2730	900	225	592	2946	
300/250	1000	250	770	3152	1000	250	770	3498	
350/275	1000	275	770	4426	1000	275	770	4761	
400/275	1000	275	770	4460	1000	275	770	4795	

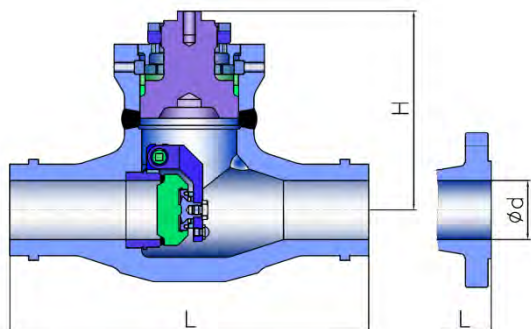

SWING CHECK VALVES

TYPE L10

TYPE DESIGNATION

L10 C/D E M1 PN/S
C
CONNECTION INTO PIPE

- 1 Flanged
- 2 Welded ends
- 8 Combined

M₁
BODY MATERIAL

- 0 Stainless steel
- 2 Cast alloy steel
- 3 Forged alloy steel
- 4 Forged carbon steel
- 5 Cast carbon steel
- LT Carbon steel for low temperatures

D
FLANGE FACING
EN 1092 - 1

- A Flat face
- B Raised face
- C Tongue face
- D Groove face
- E Spigot
- F Recess

E
CONTROL

- 7 Automatic

S
SPECIAL EXECUTION

- B With bypass
- L With lever and counterweight





Range DN: 50 ~ 1200
NPS: 2" ~ 48"



PED 97/23/EC
PED 2014/68/EU



TR TS 10/11,
12/11, 32/11



Range PN: 10 ~ 400
Class: 150 ~ 2500

Operating temperature: - 196 °C ~ + 550 °C

Connection into piping: Flanged, WAFER, welded ends, combined execution

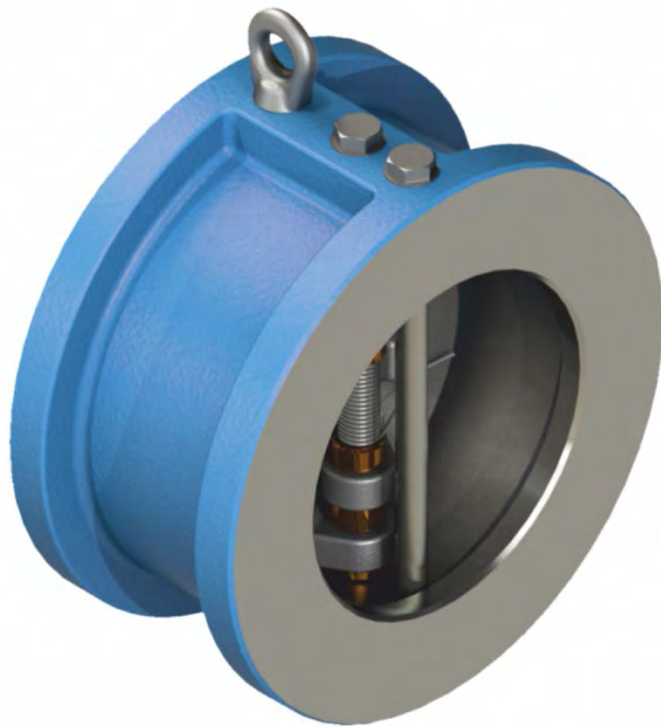

DESCRIPTION

ZK-D swing check valves are automatic check valves. They automatically prevent the reverse flow of the medium. The medium can flow in one direction only. These swing check valves are designed and manufactured to ensure maximum service life and reliability.

MATERIAL SPECIFICATION

ZK-D dual plate swing check valves are made from carbon, alloy and stainless steels. The material type can be adjusted according to the customer's request to optimally suit the operating conditions.

APPLICATION

ZK-D dual plate swing check valves are suitable for various liquids, gases and steam.

BASIC STANDARDS FOR DESIGN

Basic design

API 594, API 6D

Pressure-temperature rating

ASME B16.34, EN 12 516 - 1

Testing

API 598, EN 12 266 - 1, 2

Face-to-face dimensions

ANSI B16.10, EN 558, EN 12 982

Dimensions of the welded ends

ANSI B16.25, EN 12 627

Top Flange dimensions

None

Flange dimensions

ANSI B 16.5, ANSI B16.47 A
EN 1092 - 1

Special

NACE MR-0175

MATERIAL SPECIFICATION

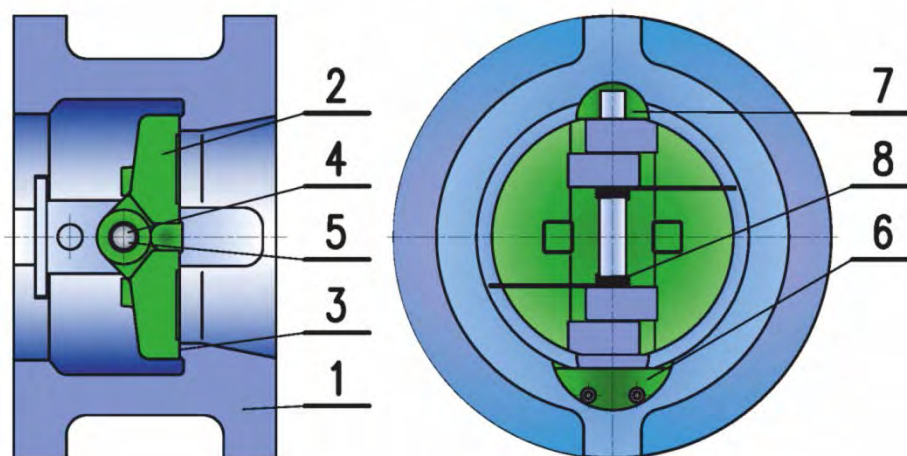

ITEM	NAME	MATERIAL				
1	BODY	A216 WCB	A217 WC6 A217 WC9 A217 C12	A350 LF2	A352 LCC	A351 CF8 A351 CF8M
2	DISC	A351 CF8M A217 Gr. CA15	A351 CF8M A217 Gr. CA15	A351 CF8M	A351 CF8M	A351 CF8M
3	BODY SEAT	A216 WCB VITON A surfacing Stellite 410 SS	A217 WC6 A217 WC9 A217 C12 EPDM Hasteloy 410 SS	A350 LF2	A352 LCC Buna N surfacing Stellite	A351 CF8 A351 CF8M VITON A surfacing Stellite
4	SUPPORT TRUNNION	316 SS 410 SS	SS304	316 SS	316 SS	316 SS
5	RESTRAINING TRUNNION	316 SS 410 SS	SS304	316 SS	316 SS	316 SS
6	LOWER BRACKET	316 SS 410 SS	SS304	316 SS	316 SS	316 SS
7	UPPER BRACKET	316 SS 410 SS	SS304	16 SS	316 SS	316 SS
8	SPRING	INCONEL X - 750	INCONEL X - 750	INCONEL X - 750	INCONEL X - 750	INCONEL X - 750

DIMENSIONS - WAFER

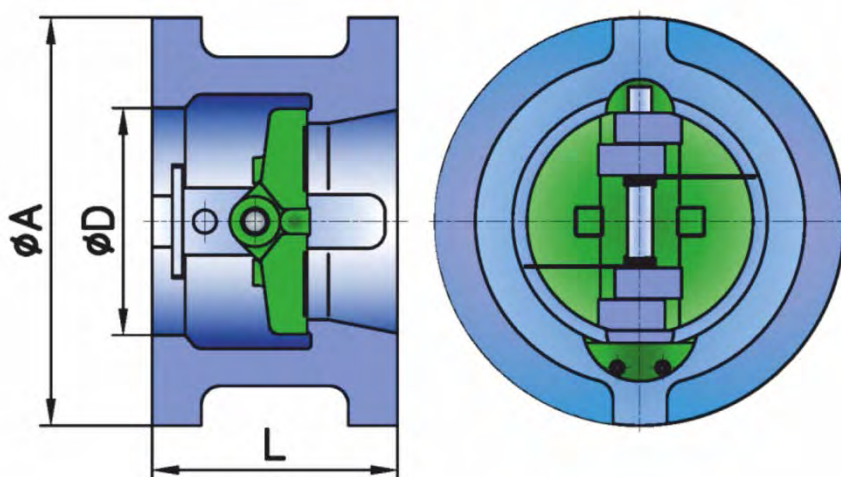

DN	PN 10, PN 16				PN 25				PN 40				PN 63				PN 100			
	A	D	L	KG	A	D	L	KG	A	D	L	KG	A	D	L	KG	A	D	L	KG
50	108	56	60	2	108	56	60	2	108	58	60	3	114	58	60	4	120	58	60	5
65	128	73	67	3	128	73	67	3	128	73	67	4	138	73	67	5	144	73	67	7
80	142	88	73	4	142	88	73	4	142	88	73	6	148	88	73	7	154	88	73	10
100	162	108	73	6	168	108	73	6	168	108	73	8	174	108	79	10	181	108	79	12
125	192	132	86	8	194	132	86	8	194	132	86	13	211	132	105	16	218	132	105	19
150	218	160	98	13	224	160	98	14	224	160	98	16	248	162	136	20	258	162	136	25
200	273	210	127	25	284	210	127	27	291	210	127	28	310	212	165	38	324	212	165	56
250	328	266	146	39	341	266	146	42	353	266	146	49	362	266	213	62	392	266	213	94
300	378	310	181	64	401	310	181	54	418	310	181	76	422	310	229	100	456	312	229	142
350	438	355	184	85	458	355	184	86	475	355	222	114	487	355	273	160	510	355	273	230
400	489	405	191	114	515	405	191	120	547	405	232	190	541	405	305	260	570	405	305	366
450	539	455	203	138	565	455	203	148	572	455	264	200	-	-	-	-	-	-	-	-
500	594	505	219	161	622	505	219	165	626	505	292	260	-	-	-	-	-	-	-	-
600	696	605	222	250	732	605	222	290	745	608	318	404	-	-	-	-	-	-	-	-
700	811	700	305	370	831	700	305	400	-	-	-	-	-	-	-	-	-	-	-	-
800	918	800	305	540	942	800	305	580	-	-	-	-	-	-	-	-	-	-	-	-
900	1018	903	368	650	1040	903	368	660	-	-	-	-	-	-	-	-	-	-	-	-
1000	1124	1055	432	900	1155	1055	432	960	-	-	-	-	-	-	-	-	-	-	-	-
1200	1340	1205	524	1420	1365	1205	524	1510	-	-	-	-	-	-	-	-	-	-	-	-

DUAL PLATE SWING CHECK VALVES

TYPE **ZK-D**

DIMENSIONS - WAFER

NPS	DN	CLASS 150				CLASS 300				CLASS 600				CLASS 900				CLASS 1500				CLASS 2500			
		A	D	L	KG	A	D	L	KG	A	D	L	KG	A	D	L	KG	A	D	L	KG	A	D	L	KG
2	50	103	56	60	2	110	58	60	3	110	58	60	4	140	58	70	8	140	58	70	8	143	48	70	10
2 1/2	65	122	73	67	3	128	73	67	4	128	73	67	5	162	73	83	11	162	73	83	11	166	58	83	18
3	80	135	88	73	4	147	88	73	6	147	88	73	8	165	90	83	14	172	90	83	19	194	68	86	26
4	100	173	108	73	6	179	108	73	8	191	108	79	11	204	108	102	20	207	108	102	26	232	94	105	40
5	125	195	132	86	8	214	132	86	15	239	136	105	20	245	136	110	30	252	136	110	51	277	106	110	59
6	150	220	160	98	13	249	160	98	18	264	162	136	26	286	162	159	45	280	162	159	68	315	162	159	90
8	200	277	210	127	25	305	210	127	31	318	212	165	55	356	212	206	84	350	212	206	130	385	186	206	150
10	250	337	266	146	39	359	266	146	51	398	266	213	103	432	266	241	145	433	266	248	210	474	232	254	240
12	300	407	310	181	64	420	310	181	83	455	312	229	140	495	312	292	220	518	312	305	384	547	272	305	440
14	350	448	355	184	85	483	355	222	117	490	355	273	223	518	355	356	350	576	355	356	550	-	-	-	-
16	400	512	405	191	114	537	405	232	190	562	400	305	360	572	400	384	470	639	400	384	635	-	-	-	-
18	450	547	455	203	138	594	455	264	200	610	450	362	395	635	450	451	605	-	-	-	-	-	-	-	-
20	500	604	505	219	163	652	505	292	265	680	500	368	518	695	496	451	820	-	-	-	-	-	-	-	-
24	600	715	605	222	285	772	608	318	410	786	600	438	836	835	600	495	1050	-	-	-	-	-	-	-	-
28	700	773	700	305	380	-	-	-	-	-	-	-	-	-	-	-	-	-	-	-	-	-	-	-	-
30	750	824	750	305	425	882	740	368	660	-	-	-	-	-	-	-	-	-	-	-	-	-	-	-	-
32	800	878	800	305	560	-	-	-	-	-	-	-	-	-	-	-	-	-	-	-	-	-	-	-	-
36	900	983	910	368	640	1044	880	483	1020	-	-	-	-	-	-	-	-	-	-	-	-	-	-	-	-
40	1000	1089	1010	419	870	1108	950	546	1348	-	-	-	-	-	-	-	-	-	-	-	-	-	-	-	-
42	1050	1142	1055	432	960	1196	1045	568	1540	-	-	-	-	-	-	-	-	-	-	-	-	-	-	-	-
48	1200	1302	1205	524	1400	1365	1190	629	2260	-	-	-	-	-	-	-	-	-	-	-	-	-	-	-	-

LUG TYPE

FLANGE MOUNTED TYPE

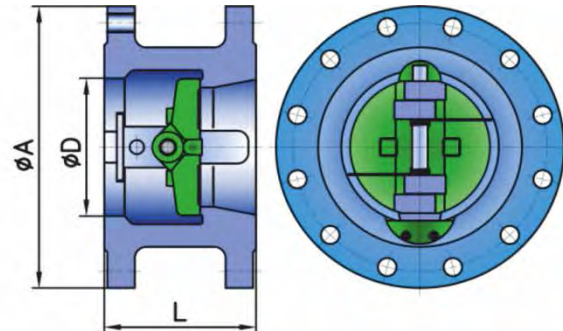
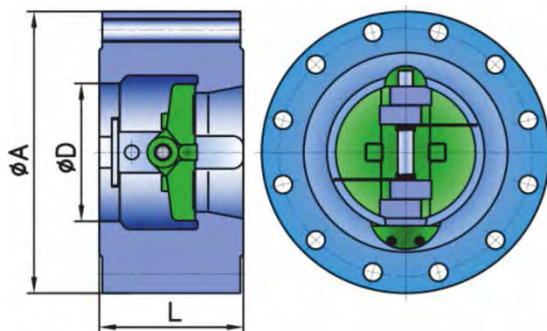

DUAL PLATE SWING CHECK VALVES

TYPE **ZK-D**

DIMENSIONS - LUG type

NPS	DN	CLASS 150				CLASS 300				CLASS 600				CLASS 900				CLASS 1500				CLASS 2500			
		A	D	L	KG	A	D	L	KG	A	D	L	KG	A	D	L	KG	A	D	L	KG	A	D	L	KG
2	50	152	57	60	7	165	57	60	8	165	57	60	8	216	57	70	16	216	57	70	16	235	57	70	19
3	80	191	87	73	12	210	87	73	14	210	87	73	14	241	87	83	25	267	87	83	29	305	87	86	38
4	100	229	113	73	19	254	113	73	23	273	113	79	30	292	113	102	45	311	113	102	51	356	113	108	69
6	150	279	166	98	32	318	166	98	45	356	166	137	81	381	166	159	115	394	166	159	119	483	166	159	184
8	200	343	207	127	63	381	207	127	78	419	207	165	134	470	207	210	217	483	207	210	283	-	-	-	-
10	250	406	260	146	93	445	260	146	115	508	260	213	234	546	260	241	330	584	260	248	361	673	260	254	489
12	300	483	300	181	170	521	300	181	242	559	300	229	304	610	300	292	509	673	300	305	637	762	300	305	747
14	350	533	339	184	199	584	339	222	237	603	339	273	571	641	339	356	775	749	339	356	1097	-	-	-	-
16	400	597	387	191	246	648	387	232	489	686	387	305	548	705	387	384	609	826	387	384	1152	-	-	-	-
18	450	635	438	203	290	711	438	264	558	743	438	362	1078	787	438	451	1450	914	438	468	1775	-	-	-	-
20	500	699	487	219	348	775	487	292	766	813	487	368	1297	857	487	451	1960	984	487	533	2675	-	-	-	-
24	600	813	579	222	396	914	579	318	1190	940	579	438	1554	1041	579	495	2351	1168	579	559	3280	-	-	-	-
26	650	870	629	256	1254	972	629	356	1542	1016	629	457	1766	1086	629	533	2479	-	-	-	-	-	-	-	-
28	700	927	680	381	1276	1035	680	381	1395	1073	680	483	1827	1168	680	572	3021	-	-	-	-	-	-	-	-
30	750	984	735	305	987	1092	735	368	1996	1130	735	505	3045	1232	735	635	3835	-	-	-	-	-	-	-	-
32	800	1060	787	356	2925	1149	787	406	3428	1194	787	533	3655	1314	787	660	4265	-	-	-	-	-	-	-	-
36	900	1168	865	368	1430	1270	865	483	2661	1314	865	635	5896	-	-	-	-	-	-	-	-	-	-	-	-
40	1000	1289	987	432	1386	1238	987	546	3827	1321	987	660	7862	1511	987	762	8328	-	-	-	-	-	-	-	-
42	1050	1346	1062	432	2377	1289	1015	568	5515	1403	972	702	6572	-	-	-	-	-	-	-	-	-	-	-	-
48	1200	1511	1193	524	4174	1467	1136	629	6239	-	-	-	-	-	-	-	-	-	-	-	-	-	-	-	-

DIMENSIONS - FLANGE MOUNTED type

DIAMETER		CLASS 150				CLASS 300				CLASS 600				CLASS 900			
NPS	DN	A	D	L	KG	A	D	L	KG	A	D	L	KG	A	D	L	KG
2	50	152	60	60	7	165	60	60	9	165	60	60	12	216	60	70	16
2 1/2	65	178	73	67	11	191	73	67	14	-	-	-	-	-	-	-	-
3	80	190	73	73	14	210	74	73	20	210	74	73	25	241	74	83	40
4	100	229	114	73	20	254	114	73	31	273	114	79	46	292	114	102	64
6	150	280	168	98	36	318	168	98	60	356	168	137	98	381	168	159	115
8	200	343	207	127	49	381	219	127	100	419	219	165	173	470	219	206	249
10	250	406	260	146	82	444	273	146	157	508	260	213	183	546	260	241	203
12	300	483	300	181	125	521	300	181	153	559	300	229	239	610	300	292	347
14	350	533	339	184	144	584	339	222	207	604	339	273	378	641	339	356	560
16	400	597	387	191	176	648	387	232	301	686	387	305	451	705	387	384	547
18	450	635	438	203	210	711	438	264	392	743	438	362	598	787	438	451	835
20	500	699	487	219	270	775	487	292	489	813	487	368	762	857	487	451	1783
24	600	813	579	222	381	914	579	318	756	940	579	438	1143	1041	579	495	1888
26	650	870	629	356	1007	972	629	356	1238	1016	629	457	1418	1086	629	533	1991
28	700	927	680	381	1025	1035	680	381	1120	1073	680	483	1467	1168	680	572	2426
30	750	984	735	305	793	1092	735	368	1603	1130	735	505	2445	1232	735	635	3080
32	800	1060	784	356	2349	1149	784	406	2753	1194	784	533	2935	1314	784	660	3425
36	900	1168	865	368	1148	1270	865	483	2137	1314	865	635	4735	-	-	-	-
40	1000	1289	987	432	1515	1238	909	546	3073	1321	909	660	6314	1511	909	762	6688
42	1050	1346	1062	432	1909	1289	1015	568	4429	1403	972	702	5278	-	-	-	-
48	1200	1511	1193	524	3352	1467	1136	629	5010	1594	1136	787	6092	-	-	-	-

TYPE DESIGNATION

ZK-D C E M₁ PN or Class/S

C

CONNECTION INTO PIPE

- 0L** LUG type
- 0W** WAFER type
- 1** Flanged
- 2** Welded

M₁

BODY MATERIAL

- 0** Stainless steel
- 2** Cast alloy steel
- 3** Forged alloy steel
- 4** Forged carbon steel
- 5** Cast carbon steel
- LT** Carbon steel for low temperatures

D

FLANGE FACING

ANSI B16.5

- PFF** Flat sealing face
- RF** Raised face
- LTF** Large tongue
- STF** Small tongue
- LGF** Large groove
- SGF** Small groove
- LMF** Large male
- SMF** Small male
- LFF** Large female
- SFF** Small female
- RTJ** Ring joint

EN 1092 - 1

- A** Flat face
- B** Raised face
- C** Tongue face
- D** Groove face
- E** Spigot
- F** Recess
- G** O - ring recess
- H** O - ring groove

E

CONTROL

- 7** Automatic

S

SPECIAL EXECUTION

- As** Antistatic





Range DN: 40 ~ 600
NPS: 1 1/2" ~ 24"



PED 97/23/EC
PED 2014/68/EU



TR TS 10/11,
12/11, 32/11



Range PN: 10 ~ 100
Class: 150 ~ 600

Operating temperature: - 196 °C ~ + 550 °C (depending on the material of seat ring)

Connection into piping: WAFER type

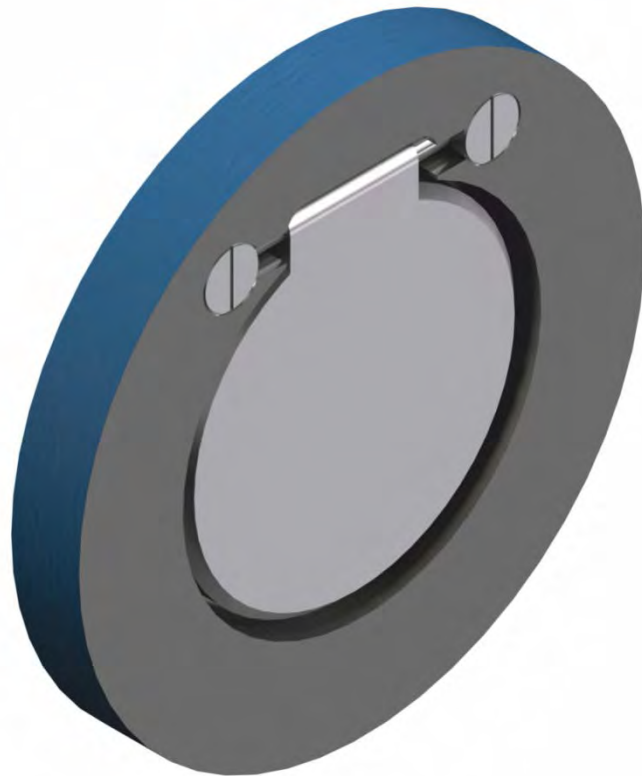

DESCRIPTION

ZK-S swing check valves are automatic check valves. They automatically prevent the reverse flow of the medium. The medium can flow in one direction only. These swing check valves are designed and manufactured to ensure maximum service life and reliability.

MATERIAL SPECIFICATION

ZK-S swing check valves are made from carbon, alloy and stainless steels. The material type can be adjusted according to the customer's request to optimally suit the operating conditions.

APPLICATION

ZK-S swing check valves are suitable for various liquids, gases and steam

BASIC STANDARDS FOR DESIGN

Basic design

EN 14 341

Pressure-temperature rating

EN 12 516 - 1

Testing

EN 12 266 - 1

Face-to-face dimensions

Determined by the manufacturer

Dimensions of the welded ends

None

Top Flange dimensions

None

Flange dimensions

None

Special

NACE MR-0175

MATERIAL SPECIFICATION

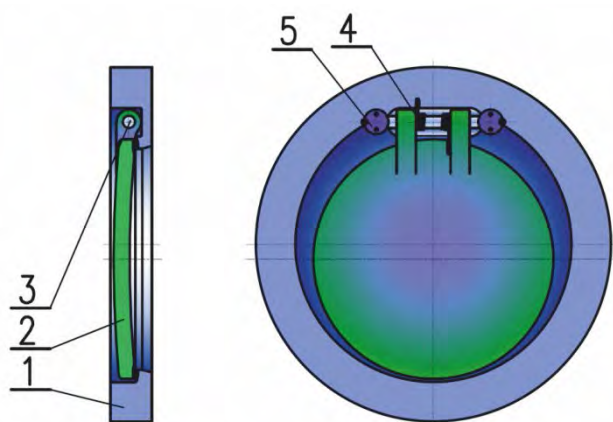

ITEM	NAME	MATERIAL
1	BODY	P235 GH, P265GH, P355 NL1, A105, A350 LF2, A182 F5, A182 F11, A182 F22 + surfacing
2	DISC	P235 GH, P265GH, P355 NL1, A105, A350 LF2, A182 F5, A182 F11, A182 F22 + surfacing or ring EPDM, NBR, HNBR, VITON, PTFE
3	PIN	17 027, 1.4021, 1.4541, 1.4571, AISI 410, AISI 420, A182 F6a, A182 F304, A182 F304L, A182 F316, A182 F316L
4	SPRING	1.4301, INCONEL X750, AISI 304, AISI316
5	SLEEVE	17 027, 1.4021, 1.4541, 1.4571, AISI 410, AISI 420, A182 F6a, A182 F304, A182 F304L, A182 F316, A182 F316L

DIMENSIONS

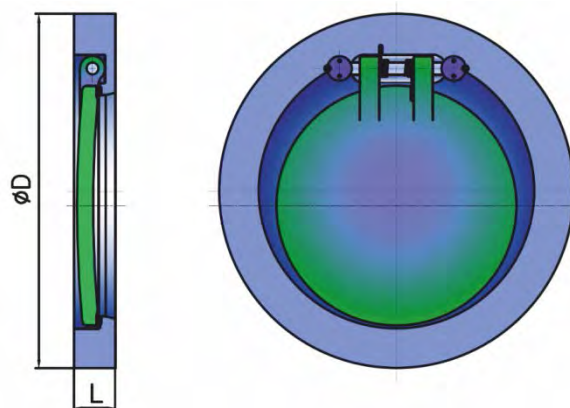

DN	PN 10			PN 16			PN 25			PN 40			PN 63			PN100		
	L	ØD	Mass (kg)	L	ØD	Mass (kg)	L	ØD	Mass (kg)	L	ØD	Mass (kg)	L	ØD	Mass (kg)	L	ØD	Mass (kg)
40	16	95	0,8	16	95	0,8	16	95	0,8	16	95	0,8	16	100	0,9	16	100	0,9
50	16	109	1	16	109	1	16	109	1	16	109	1	16	110	1	16	112	1,1
65	16	129	1,3	16	129	1,3	16	129	1,3	16	129	1,3	16	133	1,4	16	138	1,4
80	16	144	1,7	16	144	1,7	16	144	1,7	16	144	1,7	16	144	1,7	16	148	1,8
100	16	164	2,2	16	165	2,2	16	170	2,4	16	170	2,4	16	170	2,4	16	173	2,5
125	20	195	3,2	20	195	3,2	20	195	3,2	20	198	3,3	20	204	3,5	20	210	3,6
150	22	220	5,3	22	220	5,3	22	226	5,4	22	226	5,4	22	240	5,5	22	250	5,6
200	24	275	11,5	24	275	11,5	24	288	11,7	24	293	11,9	24	300	12	24	317	12,2
250	26	330	15	26	330	15	26	343	15,2	26	355	15,3	26	358	15,4	26	383	15,6
300	32	380	25	32	395	32,2	32	403	32,3	32	420	32,4	32	416	32,6	32	449	32,8
350	38	440	37	38	446	37,2	38	460	37,5	38	477	37,7	38	480	37,8	38	505	38
400	44	490	55	44	495	55	44	517	55,5	44	549	55,5	44	535	55,5	44	565	55,5
450	50	540	65	50	557	65,3	50	567	65,4	50	574	65,5	-	-	-	-	-	-
500	56	595	105	56	619	105,2	56	627	105,3	56	631	105,4	56	648	105,5	56	696	106
600	62	698	147	62	737	147,3	62	734	147,3	62	772	147,8	62	755	147,2	-	-	-

NPS	DN	ØD			L		
		CLASS 150	CLASS 300	CLASS 600	CLASS 150	CLASS 300	CLASS 600
1 1/2	40	87	95	95	19	19	19
2	50	104	111	111	19	19	19
2 1/2	65	124	130	130	19	19	19
3	80	136	149	149	19	19	19
4	100	174	180	193	19	19	22
6	150	222	250	266	19	22	28
8	200	279	307	620	28	28	38
10	250	339	362	400	28	38	57
12	300	409	422	457	38	51	60
14	350	450	485	192	44	51	67
16	400	514	539	565	51	51	73
20	500	549	696	612	60	76	83
24	600	606	654	582	64	83	92

TYPE DESIGNATION

ZK-S C E M₁/M₂ PN or Class

C CONNECTION INTO PIPE

0 WAFER type

E CONTROL

7 Automatic

M₁ BODY/DISC MATERIAL

0 Stainless steel
 3 Alloy steel forged
 4 Carbon steel forged
 LT Carbon steel for low temperatures

M₂ SEAT RING MATERIAL

E EPDM
 N NBR
 HN HNBR
 P CR
 S WMQ
 T PTFE
 V VITON

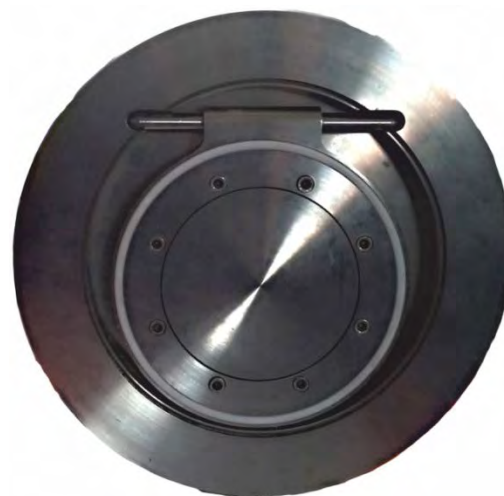



Range DN: 15 ~ 200



PED 97/23/EC
PED 2014/68/EU



TR TS 10/11,
32/11



Range PN: 2,5 ~ 16

Operating temperature: - 35 °C ~ + 170 °C (depending on the diaphragm material)

Connection into piping: Flanged, welded ends, combined execution



DESCRIPTION

The SDV type valves are controlled, shut-off or regulating valves. They are designed to stop, regulate or allow the flow of the medium by external operation, either manually or via the installed drive. The medium can flow in two direction. They are designed and manufactured to ensure maximum service life and reliability.

MATERIAL SPECIFICATION

SDV diaphragm valves are made from carbon, alloy and stainless steels. The material type can be adjusted according to the customer's request to optimally suit the operating conditions.

APPLICATION

SDV type valves are suitable for various inert and corrosive liquid and gaseous media – insensitive to particulate media.

BASIC STANDARDS FOR DESIGN

Basic design

EN 12 516 - 1

Pressure-temperature rating

EN 12 516 - 1

Testing

EN 12 266 - 1, 2

Face-to-face dimensions

EN 558

Dimensions of the welded ends

EN 12 627

Top Flange dimensions

EN ISO 5210

Flange dimensions

EN 1092 - 1

DIAPHRAGM VALVES

TYPE SDV

MATERIAL SPECIFICATION

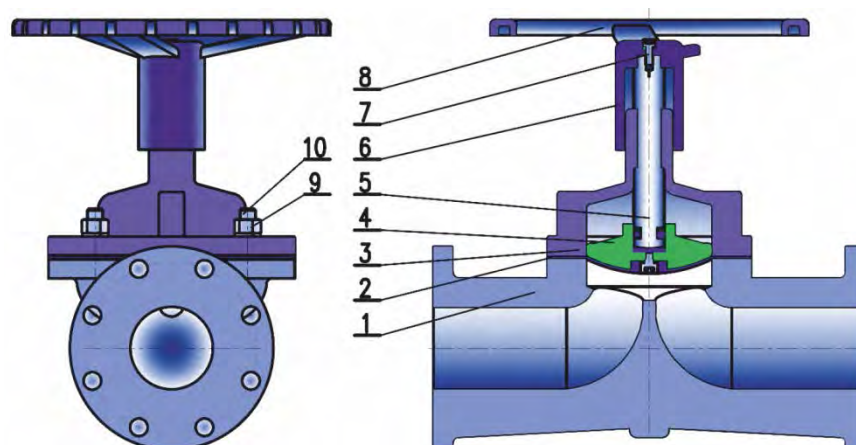

ITEM	NAME	MATERIAL
1	BODY	1.0619 (GP240GH), 1.4408(GX5CrNiMo19-11-2)
2	DIAPHRAGM ASSEMBLY*	PTFE/EPDM
3	BONNET	1.0619 (GP240GH), 1.4408(GX5CrNiMo19-11-2)
4	BAYONET LOCK	1.4408(GX5CrNiMo19-11-2)
5	STEM	1.4305 (X2CrNi19-11)
6	CLAMP	1.0619 (GP240GH), 1.4408(GX5CrNiMo19-11-2)
7	BOLT	1.4310 (X10CrNi18-8)
8	HANDWHEEL	1.0619 (GP240GH)
9	NUT	1.4310 (GX5CrNi19-10)
10	BOLT	1.4310 (GX5CrNi19-10)

DIMENSIONS

DN	Max. bar	L	H	ØD	Mass (kg)
15	16	130	115	85	2,5
20	16	150	117	85	3
25	6	160	124	85	3,8
32	16	180	134	85	5,2
40	16	200	137	120	7,4
50	16	230	186	120	9,7
65	10	290	208	180	13,5
80	8	310	233	180	18
100	7	350	282	250	30
125	7	400	345	250	43
150	7	480	412	400	66
200	5	600	442	400	122

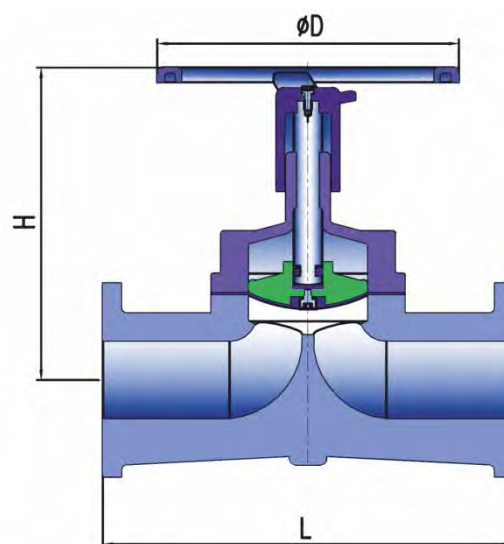

DIAPHRAGM VALVES

TYPE SDV

TYPE DESIGNATION

SDV C/D E M1/M2 PN/S

C CONNECTION INTO PIPE

- 1 Flanged

M₁ BODY MATERIAL

- 0 Stainless steel
 2 Cast alloy steel
 5 Cast carbon steel
 LT Carbon steel for low temperatures

S SPECIAL EXECUTION

- As Antistatic

D FLANGE FACING

EN 1092 - 1

- A Flat face
 B Raised face
 C Tongue face
 D Groove face
 E Spigot
 F Recess
 G O - ring recess
 H O - ring groove

E CONTROL

- 1 Lever, handwheel
 5 Pneumatic actuator
 9 Without control

M₂ DIAPHRAGM MATERIAL

- E EPDM
 N NBR
 HN HNBR
 P CR
 S WMQ
 T PTFE
 V VITON





Range DN: 15 ~ 1000
NPS: 1/2" ~ 40"



PED 97/23/EC
PED 2014/68/EU



TR TS 10/11,
12/11, 32/11



Range PN: 10 ~ 400
Class: 150 - 2500

Operating temperature: - 196 °C ~ + 550 °C

Connection into piping: Flanged, welded ends, threaded ends, combined execution



DESCRIPTION

CHOV - change over valves are controlled change-over valves. They are designed to stop or allow the flow of the medium by external operation, either manually or via the installed drive, and they allow the continuous operation of the piping when performing maintenance of the safety valve. These valves are designed and manufactured to ensure maximum service life and reliability.

MATERIAL SPECIFICATION

CHOV - change over valves are made from carbon, alloy and stainless steels. The material type can be adjusted according to the customer's request to optimally suit the operating conditions.

APPLICATION

CHOV - change over valves are suitable for various liquids, gases and steam.

BASIC STANDARDS FOR DESIGN

Basic design

EN 12 516 - 1, ASME B16.34

Pressure-temperature rating

ASME B16.34, EN 12 516 - 1

Testing

API 598 EN 12 266 - 1, 2

Face-to-face dimensions

See the table of dimensions

Dimensions of the welded ends

ANSI B16.25, EN 12 627

Top Flange dimensions

EN ISO 5210

Flange dimensions

ANSI B 16.5, ANSI B16.47A, EN1092 - 1

Special

NACE MR-0175

CHANGE OVER VALVES

TYPE CHO

MATERIAL SPECIFICATION

Pos.	Designation	Material			
1	Bottom body	P355 NH	P355 QH	1.4541	1.4401
2	Middle body	P355 NH	P355 QH	1.4541	1.4401
3	Top body	P355 NH	P355 QH	1.4541	1.4401
4	Seat	P355 NH + overlay	P355 QH + overlay	1.4541	1.4401
5	Disc	P355 NH + overlay	P355 QH + overlay	1.4541	1.4401
6	Stem	X20 Cr13, M300 Bohler			
7	Yoke	P355 NH	P355 QH	1.4541	1.4541
8	Gland flange	P355 NH	P355 QH	1.4541	1.4541
9	Thrust ring	P355 NH	P355 QH	1.4541	1.4541
10	Guide plate	P355 NH	P355 QH	1.4541	1.4541
11	Chain wheel hub	P355 NH	P355 QH	1.4541	1.4541
12	Guide sleeve	Bronze			
13	Disc nut	P355 NH	P355 QH	1.4541	1.4541
14	Stem nut	Bronze			
15	Bolt	25CrMo4	Strength class 8.8	A2 - 70	A2 - 70
16	Bolt	25CrMo4		A2 - 70	A2 - 70
17	Nut	A2 - 70	Strength class 8	A2 - 70	A2 - 70
18	Nut	A2 - 70		A2 - 70	A2 - 70
19	Gasket	Graphite	Graphite	Graphite	Graphite
20	Gland packing	Graphite	Graphite	Graphite	Graphite

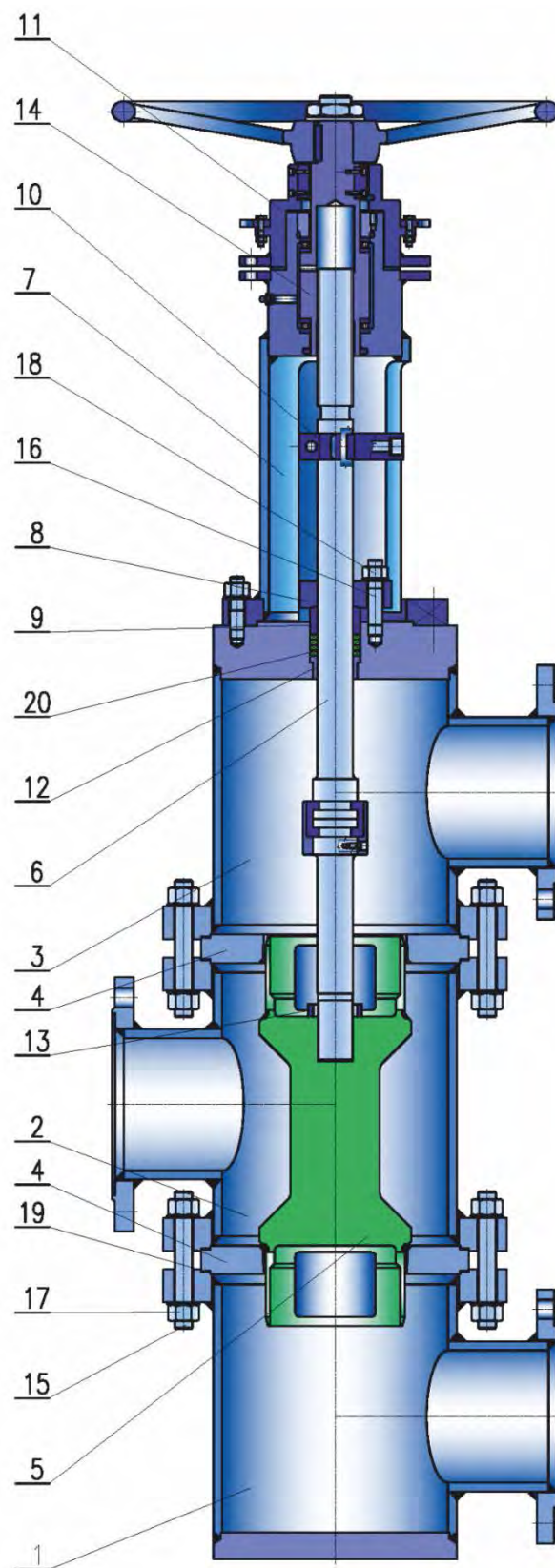

CHANGE OVER VALVES

TYPE CHO

DIMENSIONS

DN	PN 10, 16, 25, 40				PN 63, 100				PN 160, 250				PN 325, 400			
	A	B1	B2	C	A	B1	B2	C	A	B1	B2	C	A	B1	B2	C
15	70	200	-	250	90	260	-	320	120	340	-	420	160	440	-	545
20	80	200	220	250	100	260	290	320	130	340	340	420	170	440	500	545
25	85	220	280	365	110	290	360	480	140	380	470	620	180	500	600	800
32	100	280	320	400	130	360	400	500	170	470	520	650	220	600	680	850
40	120	320	370	430	160	400	500	560	200	520	650	730	260	680	850	950
50	150	370	-	490	190	500	-	640	250	650	-	830	330	850	-	1000
65	150	370	470	490	200	500	600	640	260	650	800	830	340	850	1000	1000
80	180	470	540	640	230	600	700	830	300	800	900	1080	400	1000	1200	1400
100	200	540	700	690	260	700	900	900	340	900	1200	1170	440	1200	1550	1500
125	220	700	-	740	290	900	-	960	380	1200	-	1250	-	-	-	-
150	250	700	800	740	320	900	1000	960	420	1200	1300	1250	-	-	-	-
200	300	800	980	1060	390	1000	1300	1350	500	1300	1700	1800	-	-	-	-
250	350	980	1050	1285	460	1300	1400	1700	600	1700	1800	2200	-	-	-	-
300	400	1050	1200	1300	500	1400	1500	1700	-	-	-	-	-	-	-	-
350	450	1200	1250	1500	600	1500	1600	2000	-	-	-	-	-	-	-	-
400	500	1250	1600	1600	650	1600	-	2100	-	-	-	-	-	-	-	-
500	550	1600	1800	1600	-	-	-	-	-	-	-	-	-	-	-	-
600	600	1800	2100	1700	-	-	-	-	-	-	-	-	-	-	-	-
700	650	2100	2500	1700	-	-	-	-	-	-	-	-	-	-	-	-
800	750	2500	2800	1900	-	-	-	-	-	-	-	-	-	-	-	-
900	850	2800	3200	2100	-	-	-	-	-	-	-	-	-	-	-	-
1000	900	3200	-	2600	-	-	-	-	-	-	-	-	-	-	-	-

NPS	CLASS 150, 300				CLASS 400, 600				CLASS 900, 1500				CLASS 2500			
	A	B1	B2	C	A	B1	B2	C	A	B1	B2	C	A	B1	B2	C
1/2	70	200	-	250	90	260	-	320	120	340	-	420	160	440	-	545
3/4	80	200	220	250	100	260	290	320	130	340	340	420	170	440	500	545
1	85	220	280	365	110	290	360	480	140	380	470	620	180	500	600	800
1 1/4	100	280	320	400	130	360	400	500	170	470	520	650	220	600	680	850
1 1/2	120	320	370	430	160	400	500	560	200	520	650	730	260	680	850	950
2	150	370	-	490	190	500	-	640	250	650	-	830	330	850	-	1000
2 1/2	150	370	470	490	200	500	600	640	260	650	800	830	340	850	1000	1000
3	180	470	540	640	230	600	700	830	300	800	900	1080	400	1000	1200	1400
4	200	540	700	690	260	700	900	900	340	900	1200	1170	440	1200	1550	1500
5	220	700	-	740	290	900	-	960	380	1200	-	1250	-	-	-	-
6	250	700	800	740	320	900	1000	960	420	1200	1300	1250	-	-	-	-
8	300	800	980	1060	390	1000	1300	1350	500	1300	1700	1800	-	-	-	-
10	350	980	1050	1285	460	1300	1400	1700	600	1700	1800	2200	-	-	-	-
12	400	1050	1200	1300	500	1400	1500	1700	-	-	-	-	-	-	-	-
14	450	1200	1250	1500	600	1500	1600	2000	-	-	-	-	-	-	-	-
16	500	1250	1500	1600	650	1600	-	2100	-	-	-	-	-	-	-	-
18	500	1500	1600	1600	-	-	-	-	-	-	-	-	-	-	-	-
20	550	1600	1800	1600	-	-	-	-	-	-	-	-	-	-	-	-
24	600	1800	2100	1700	-	-	-	-	-	-	-	-	-	-	-	-
28	650	2100	2500	1700	-	-	-	-	-	-	-	-	-	-	-	-
32	750	2500	2800	1900	-	-	-	-	-	-	-	-	-	-	-	-
36	850	2800	3200	2100	-	-	-	-	-	-	-	-	-	-	-	-
40	900	3200	-	2600	-	-	-	-	-	-	-	-	-	-	-	-

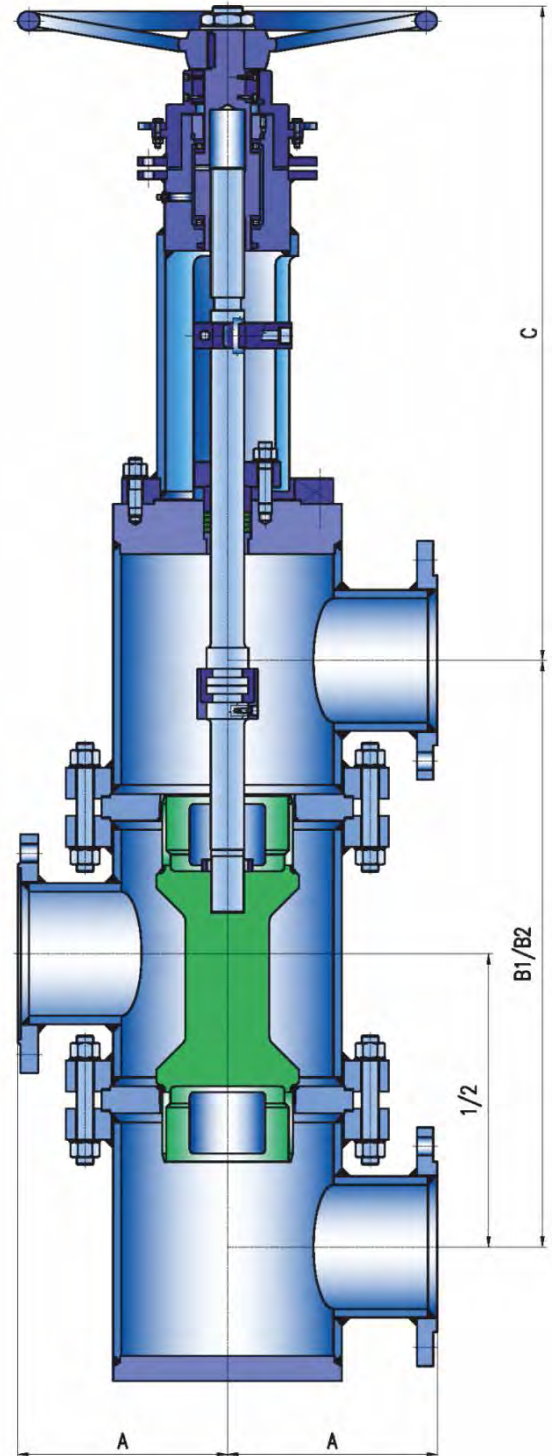

CHANGE OVER VALVES

TYPE CHO

TYPE DESIGNATION

CHOV C/D E M₁ PN or Class/S

C CONNECTION INTO PIPE

- 1 Flanged
- 2 Welded ends
- 6 Threaded flange

M₁ BODY MATERIAL

- 0 Stainless steel
- 3 Forged steel alloy
- 4 Forged carbon steel
- LT Carbon steel for low temperatures

E CONTROL

- 2 Gearbox + hand wheel
- 3 Electric actuator
- 4 Gearbox + electric actuator

S SPECIAL EXECUTIONS

- V Bellows
- HJ Heating shell

D FLANGE FACING

EN 1092 - 1

- A Flat face
- B Raised face
- C Tongue face
- D Groove face
- E Spigot
- F Recess
- G O - ring recess
- H O - ring groove

ASME B 16.5

- PFF Flat sealing face
- RF Raised face
- LTF Large tongue
- STF Small tongue
- LGF Large groove
- SGF Small groove
- LMF Large male
- SMF Small male
- LFF Large female
- SFF Small female
- RTJ Ring joint

OTHERS

- L lens





Range NPS: 1/4" ~ 20"



PED 97/23/EC
PED 2014/68/EU



TR TS 10/11,
12/11, 32/11



Range Class: 150 ~ 2500



EN 12 569
CERTIFICATE

Operating temperature: -196 °C ~ 550 °C

Connection into piping: Flanged, welded ends, threaded ends, combined execution



DESCRIPTION

C09 1 valves are controlled shut-off valves. They are designed to stop or allow the flow of the medium by external operation, either manually or via the installed drive. If, upon the customer's request, they are fitted with a regulating cone, they can be used to regulate the flow of the medium. The medium can flow in one direction only. These valves are designed and manufactured to ensure maximum service life and reliability.

MATERIAL SPECIFICATION

C09 1 valves are made from carbon, alloyed and stainless steels. The material type can be adjusted according to the customer's request to optimally suit the operating conditions.

APPLICATION

C09 1 valves are mainly suitable for various chemicals and petrochemicals, liquids, gases and steam.

BASIC STANDARDS FOR DESIGN

Basic design

API 602, API 623, ASME B16.34

Pressure-temperature rating

ASME B16.34

Testing

API 598, EN 12 266 - 1, 2

Face-to-face dimensions

ANSI B16.10

Dimensions of the welded ends

ANSI B16.25, ASME B16.11

Top Flange dimensions

EN ISO 5210

Flange dimensions

ANSI B 16.5

Special

NACE MR-0175

GLOBE VALVES

TYPE C09 1

APPLICATION

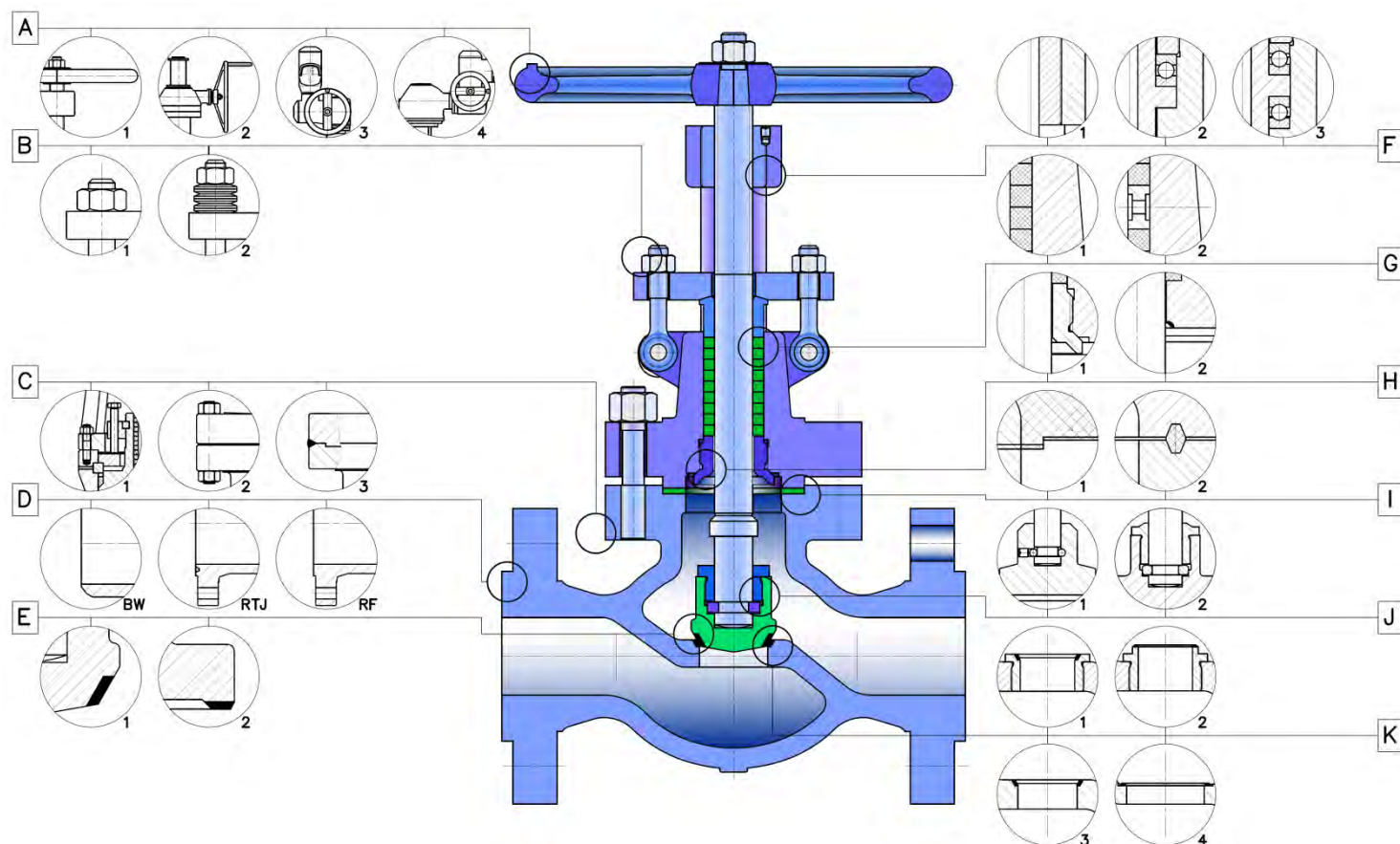

A - Control

- hand wheel
- gearbox
- electric actuator
- electric actuator with gearbox

B – Gland compression

- in case of valve operation with cyclic changes in pressure or at high pressures and temperatures, gland compression by means of Belleville springs, which ensure a constant pre-stress in packing, is preferred.

C – Bonnet execution

- pressure seal bonnet is used for high pressures, temperatures and valve operation with cyclic changes of pressure
- bonnet bolted to the body
- the bonnet welded to the body

D – Connection to piping

- flanged
- threaded
- welded
- with welded ends according to customer's requirements

E – Disc execution

- with flat smooth sealing surface
- with conical sealing surface

F – Bedding of stem nut

- Depending on the control power and method of valve control applied
- the stem nut can be screwed into the bonnet
 - combination of sliding and rolling stem nut bedding
 - bedding of stem nut between two axial rolling bearings

G - Execution of gland

- standard
- double stem packing with lantern ring – shall be chosen according to working conditions

H – Back-seat execution

- screwed into the bonnet
- integral part of the bonnet

I – Bonnet sealing

- class 150, 300 – by gasket for male – female body/bonnet connection
- class 600, 900 - by RTJ ring
- class 1500, 2500 – by pressure seal bonnet

J - Connection of the disc with stem

- by means of small balls, inserted into the disc
- by means of split ring mounted on the stem and the threaded ring screwed into the disc

K - Seats execution

- the seats are screwed into the body
- the seats are welded on
- the sealing seats' surface is flat or conical, depending on pressure of medium

GLOBE VALVES

TYPE C09 1

MATERIAL SPECIFICATION - CAST

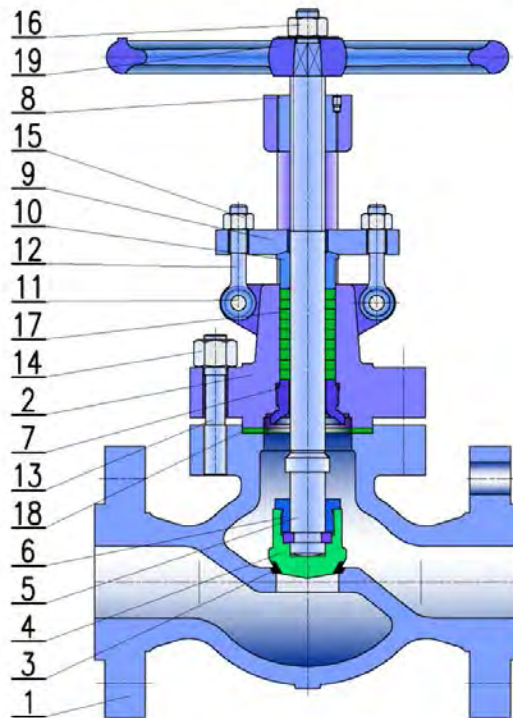

Pos.	Designation	WCB	LCC	LCB	WC6	WC9	C5	C12	CF8 / 304	CF8M / 316
1	Body	A216 WCB	A352 LCC	A352 LCB	A217 WC6	A217 WC9	A217 C5	A217 C12	A351 CF8	A351 CF8M
2	Bonnet	A216 WCB	A352 LCC	A352 LCB	A217 WC6	A217 WC9	A217 C5	A217 C12	A351 CF8	A351 CF8M
3	Seat	A105 + overlay	A352 LF2 + overlay	A352 LF2 + overlay	A182 F5 + overlay	A182 F5 + overlay	A182 F5 + overlay	A182 F5 + overlay	A351 CF8 + overlay	A351 CF8M + overlay
4	Plug	A216 WCB + overlay	A352 LCC + overlay	A352 LCB + overlay	A217 WC6 + overlay	A217 WC9 + overlay	A217 C5 + overlay	A217 C12 + overlay	A351 CF8 + overlay	A351 CF8M + overlay
5	Stem	A182 F6a	A182 F6a	A182 F6a	A182 F6a	A182 F6a	A182 F6a	A182 F6a	A182 F304	A182 F316
6	Screwed bushing	A182 F6a	A182 F6a	A182 F6a	A182 F6a	A182 F6a	A182 F6a	A182 F6a	A351 CF8	A351 CF8M
7	Back seat insert	A182 F6a	A182 F6a	A182 F6a	A182 F6a	A182 F6a	A182 F6a	A182 F6a	A351 CF8	A351 CF8M
8	Stem nut	A439 D2	A439 D2	A439 D2	A439 D2	A439 D2	A439 D2	A439 D2	A439 D2	A439 D2
9	Gland flange	A216 WCB	A352 LCC	A352 LCB	A217 WC6	A217 WC9	A217 C5	A217 C12	A351 CF8	A351 CF8M
10	Stuffing box bushing	A182 F6a	A182 F6a	A182 F6a	A182 F6a	A182 F6a	A182 F6a	A182 F6a	A182 F304	A182 F316
11	Pin	A36	A276 410	A276 410	A276 410	A276 410	A276 410	A276 410	304	316
12	Eye bolt	A193 B7	A320 L7	A320 L7	A193 B16	A193 B16	A193 B16	A193 B16	A193 B8	A193 B8M
13	Bolt	A193 B7	A320 L7	A320 L7	A193 B16	A193 B16	A193 B16	A193 B16	A193 B8	A193 B8M
14	Nut	A194 2H	A194 4	A194 4	A194 B8M	A194 B8M	A194 B8M	A194 B8M	A194 8	A194 8M
15	Nut	A194 2H	A194 4	A194 4	A194 B8M	A194 B8M	A194 B8M	A194 B8M	A194 8	A194 8M
16	Nut	carbon steel	carbon steel	carbon steel	carbon steel	carbon steel	carbon steel	carbon steel	carbon steel	carbon steel
17	Gland packing	graphite	graphite	graphite	graphite	graphite	graphite	graphite	graphite	graphite
18	Bonnet gasket	304 + graphite	304 + graphite	304 + graphite	304 + graphite	304 + graphite	304 + graphite	304 + graphite	304 + graphite	316 + graphite
19	Hand wheel	cast iron	cast iron	cast iron	cast iron	cast iron	cast iron	cast iron	cast iron	cast iron

Pos.	Designation	TRIM No.				
		1	5	8	11	12
4a	Plug surfaces	overlay 13 Cr	overlay Stellite 6	overlay 13 Cr	overlay Monel	overlay 316
3a	Seat surfaces	overlay 13 Cr			Stellite 6	

GLOBE VALVES

TYPE C09 1
DIMENSIONS - CAST

CLASS 150 – 300

CLASS 600 – 900

CLASS 1500 – 2500

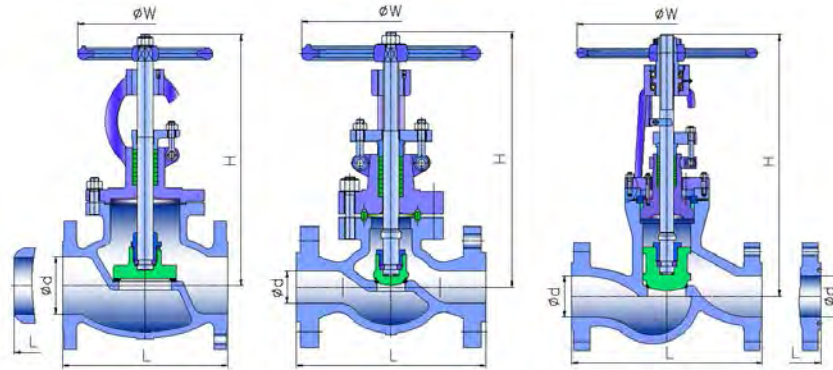

Diameter		CLASS 150							CLASS 300						
		L			d	H	W	(KG)	L			d	H	W	(KG)
NPS	DN	1/RF	1/RTJ	2					1/RF	1/RTJ	2				
2 1/2	65	216	229	216	64	360	250	43	292	308	292	64	420	200	45
3	80	241	254	241	76	390	280	47	318	334	318	76	440	280	58
4	100	292	305	292	102	445	300	70	356	370	356	102	515	350	93
5	125	356	369	356	127	480	350	95	400	416	400	127	580	350	135
6	150	406	419	406	152	520	350	118	445	461	445	152	660	400	162
8	200	495	508	495	203	600	400	170	559	575	559	203	900	550	280
10	250	622	635	622	254	773	450	280	622	638	622	254	950	600	415
12	300	698	711	698	305	880	500	378	711	727	711	305	1030	650	579
14	350	787	800	787	337	980	600	520	838	854	838	337	1150	650	867
16	400	914	927	914	387	1200	650	730	864	880	864	387	1300	460	1040
18	450	978	991	978	438	1300	650	1000	978	994	978	432	1210	610	1420
20	500	1100	1113	1100	489	1400	700	1500	1026	1045	1026	483	1300	700	1960

Diameter		CLASS 600							CLASS 900						
		L			d	H	W	(KG)	L			d	H	W	(KG)
NPS	DN	1/RF	1/RTJ	2					1/RF	1/RTJ	2				
2 1/2	65	330	333	330	64	540	300	61	419	422	419	64	630	350	68
3	80	356	359	356	76	580	350	76	381	384	381	76	665	450	95
4	100	432	435	432	102	670	450	122	457	460	457	102	800	500	160
5	125	508	511	508	127	730	500	210	559	562	559	127	920	550	270
6	150	559	562	559	152	880	500	245	610	613	610	146	1100	600	520
8	200	660	663	660	200	920	650	447	737	740	737	190	1170	700	795
10	250	787	790	787	248	1020	700	692	838	841	838	238	1608	-	1300
12	300	838	841	838	298	1680	-	1050	965	968	965	283	1799	-	1730
14	350	889	892	889	326	1680	-	1250	1029	1039	1029	311	1990	-	2060
16	400	991	994	991	376	1902	-	1590	-	-	-	-	-	-	-

Diameter		CLASS 1500							CLASS 2500						
		L			d	H	W	BEC (KG)	L			d	H	W	BEC (KG)
NPS	DN	1/RF	1/RTJ	2					1/RF	1/RTJ	2				
2 1/2	65	419	422	419	60	660	350	119	508	514	508	50	800	500	210
3	80	470	473	470	70	770	500	188	578	584	578	57	885	550	340
4	100	546	549	546	92	850	550	307	673	683	673	73	1260	600	590
6	150	705	711	705	137	1145	600	986	914	927	914	111	1905	700	880
8	200	832	842	832	178	1345	700	1430	1022	1038	1022	179	2465	-	1290
10	250	991	1001	991	239	1675	-	1675	1270	1292	1270	223	2900	-	1895
12	300	1130	1146	1130	287	1800	-	2020	1422	1444	1422	265	3100	-	2300
14	350	1257	1276	1257	315	1970	-	2800	-	-	-	-	-	-	-

MATERIAL SPECIFICATION - FORGED

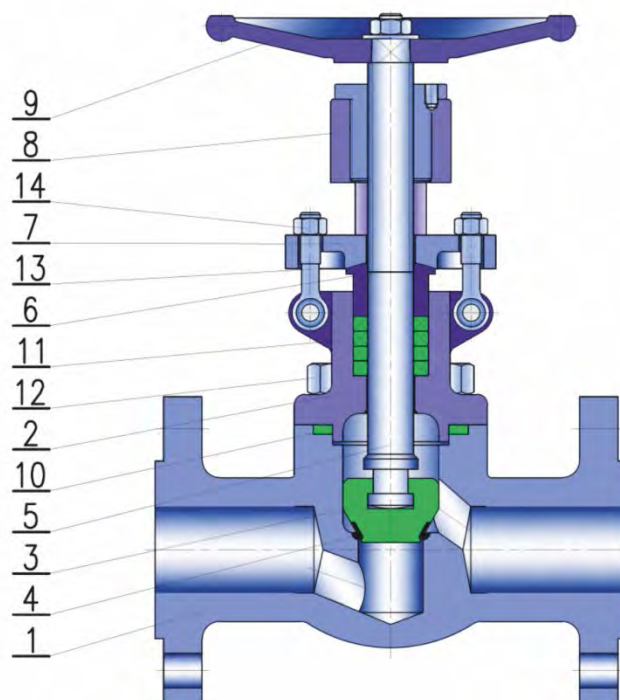

POS.	DESIGNATION	A350 LF2	A105	A182 F5	A182 F9	A182 F304	A182 F316
1	Body	A350 LF2	A105	A182 F5	A182 F9	A182 F304	A182 F316
2	Bonnet	A350 LF2	A105	A182 F5	A182 F9	A182 F304	A182 F316
3	Disc	A350 LF2 + overlay	A105 + overlay	A182 F5 + overlay	A182 F9 + overlay	A182 F304 + overlay	A182 F316 + overlay
4	Seat	A350 LF2 + overlay	A105 + overlay	A182 F5 + overlay	A182 F9 + overlay	A182 F304 + overlay	A182 F316 + overlay
5	Stem	A182 F6a	A182 F6a	A182 F6a	A182 F6a	A276 F304	A276 F316
6	Stuffing box bushing	A182 F6a	A182 F6a	A182 F6a	A182 F6a	A182 F304	A182 F316
7	Gland flange	A350 LF2	A105	A182 F5	A182 F9	A182 F304	A182 F316
8	Stem nut	bronze, A439 D2					
9	Hand wheel	cast iron					
10	Bonnet gasket	graphite, 304 + graphite, 316 + graphite					
11	Gland packing	graphite					
12	Bolt	A320 L7	A193 B7	A193 B16	A193 B16	A193 B8	A193 B8M
13	Bolt	A320 L7	A193 B7	A193 B16	A193 B16	A193 B8	A193 B8M
14	Nut	A194 4	A194 2H	A194 2H	A194 2H	A194 8	A194 8M

GLOBE VALVES

TYPE C09 1

DIMENSIONS - FORGED

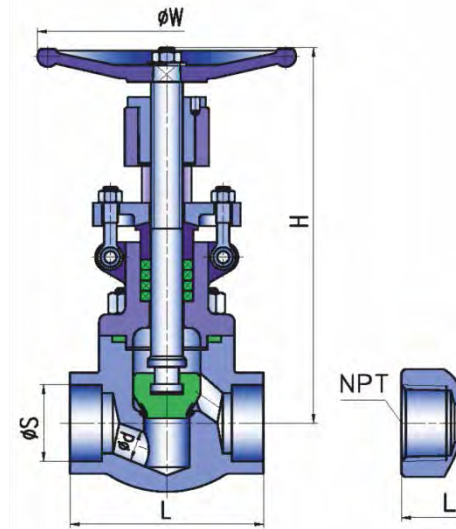
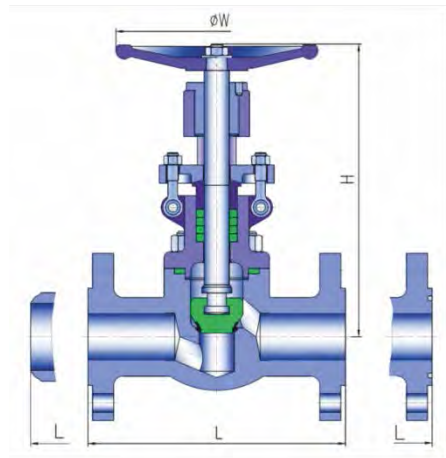

Diameter		CLASS 150										CLASS 300									
NPS	DN	L					d	S	H	W	BEC (KG)	L					d	S	H	W	BEC (KG)
		1/RF	1/RTJ	2	3	4						1/RF	1/RTJ	2	3	4					
1/4	6	108	-	108	79	79	3,2	14,2	153	100	2,2	152	-	152	79	79	3,2	14,2	153	100	2,2
3/8	10	108	-	108	79	79	5,9	17,6	153	100	2,2	152	-	152	79	79	5,9	17,6	153	100	2,2
1/2	15	108	119	108	79	79	9,5	21,8	158	100	2,2	152	164	152	79	79	9,5	21,8	158	100	2,2
3/4	20	117	130	117	92	92	12,7	27,1	163	100	3	178	190	178	92	92	12,7	27,1	163	100	3
1	25	127	140	127	111	111	17,5	33,8	193	125	4	203	216	203	111	111	17,5	33,8	193	125	4
1 1/2	40	165	178	165	120	120	28,6	48,7	250	160	7	229	241	229	120	120	28,6	48,7	250	160	7
2	50	203	190	216	140	140	36,5	61,1	291	180	11	267	283	267	140	140	36,5	61,1	291	180	11

Diameter		CLASS 600										CLASS 800									
NPS	DN	L					d	S	H	W	BEC (KG)	L					d	S	H	W	BEC (KG)
		1/RF	1/RTJ	2	3	4						1/RF	1/RTJ	2	3	4					
1/4	6	165	-	165	79	79	3,2	14,2	153	100	2,2	-	-	-	79	79	3,2	14,2	153	100	2,2
3/8	10	165	-	165	79	79	5,9	17,6	153	100	2,2	-	-	-	79	79	5,9	17,6	153	100	2,2
1/2	15	165	165	165	79	79	9,5	21,8	158	100	2,2	-	-	-	79	79	9,5	21,8	158	100	2,2
3/4	20	190	190	190	92	92	12,7	27,1	163	100	3	-	-	-	92	92	12,7	27,1	163	100	3
1	25	216	216	216	111	111	17,5	33,8	193	125	4	-	-	-	111	111	17,5	33,8	193	125	4
1 1/2	40	241	241	241	120	120	28,6	48,7	250	180	7	-	-	-	120	120	28,6	48,7	250	180	7

Diameter		CLASS 900,1500										CLASS 2500									
NPS	DN	L					d	S	H	W	BEC (KG)	L					d	S	H	W	BEC (KG)
		1/RF	1/RTJ	2	3	4						1/RF	1/RTJ	2	3	4					
1/4	6	165	-	165	111	111	3,2	14,2	207	100	2,2	-	-	-	150	150	3,2	14,2	304	138	10
3/8	10	165	-	165	111	111	5,9	17,6	207	100	2,2	-	-	-	150	150	5,9	17,6	304	138	10
1/2	15	165	165	165	111	111	9,5	21,8	207	100	2,2	-	-	-	150	150	9,5	21,8	304	138	10
3/4	20	190	190	190	130	130	12,7	27,1	240	100	3,8	-	-	-	150	150	12,7	27,1	304	138	10
1	25	216	216	216	152	152	17,5	33,8	258	125	4,2	-	-	-	210	210	17,5	33,8	362	138	22
1 1/2	40	241	241	241	220	220	28,6	48,7	337	290	13,2	-	-	-	230	230	28,6	48,7	436	234	38
2	50	292	295	292	235	235	36,5	61,1	354	337	16,8	-	-	-	230	230	36,5	61,1	436	234	38

 TYPE DESIGNATION
C09 1 AC/D E M₁ Class/S**A****BODY DESIGN**

- 1 Direct
- S Angular

E**CONTROL**

- 1 Hand wheel
- 2 Gearbox + hand wheel
- 3 Electric actuators
- 4 Gearbox + electric actuators
- 5 Pneumatic actuators
- 9 Without control

C**CONNECTION INTO PIPE**

- 1 Flanged
- 2 Welded ends
- 3 Threaded
- 4 Socket welding
- 8 Combined

M₁**BODY MATERIAL**

- 0 Stainless steel
- 2 Cast alloy steel
- 3 Forged alloy steel
- 4 Forged carbon steel
- 5 Cast carbon steel
- LT Carbon steel for low temperatures

D**FLANGE FACING****ANSI B 16.5**

- PFF Flat sealing face
- RF Raised face
- LTF Large tongue
- STF Small tongue
- LGF Large groove
- SGF Small groove
- LMF Large male
- SMF Small male
- LFF Large female
- SFF Small female
- RTJ Ring joint face

S**SPECIAL EXECUTION**

- As Antistatic execution
- R Control plug





Range DN: 6 ~ 400



PED 97/23/EC
PED 2014/68/EU



TR TS 10/11,
12/11, 32/11



Range PN: 16 ~ 400



EN 12 569
CERTIFICATE

Operating temperature: -196 °C ~ 550 °C

Connection into piping: Flanged, welded ends, combined execution



DESCRIPTION

V30 valves are controlled shut-off valves. They are designed to stop or allow the flow of the medium by external operation, either manually or via the installed drive. If, upon the customer's request, they are fitted with a regulating cone, they can be used to regulate the flow of the medium. The medium can flow in one direction only. These valves are designed and manufactured to ensure maximum service life and reliability.

MATERIAL SPECIFICATION

V30 valves are made from carbon, alloyed and stainless steels. The material type can be adjusted according to the customer's request to optimally suit the operating conditions.

APPLICATION

V30 valves are mainly suitable for various chemicals and petrochemicals, liquids, gases and steam.

BASIC STANDARDS FOR DESIGN

Basic design

EN 13 709

Pressure-temperature rating

EN 12 516 - 1

Testing

EN 12 266 - 1, 2

Face-to-face dimensions

EN 558, EN 12 982

Dimensions of the welded ends

EN 12 627

Top Flange dimensions

EN ISO 5210

Flange dimensions

EN 1092 - 1

Special

NACE MR-0175

STRUCTURAL DESIGN

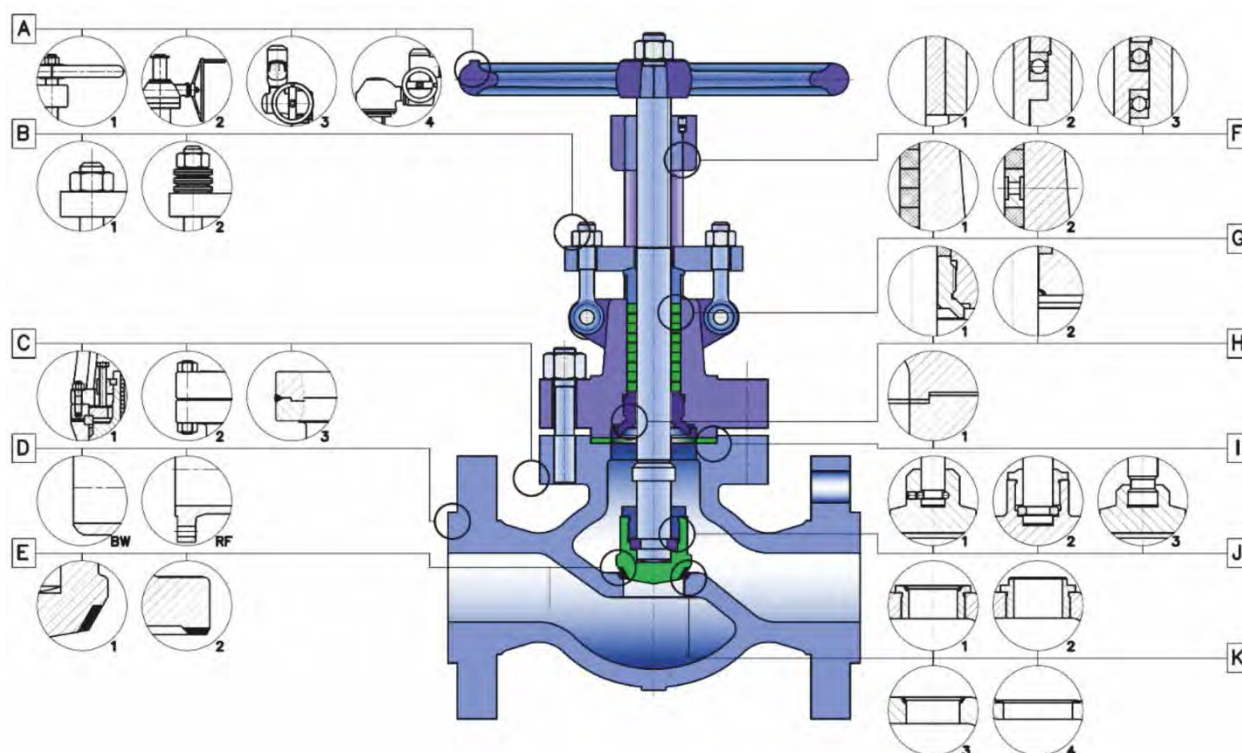

A - Control

- handwheel
- handwheel with gear box
- electric actuator
- electric actuator with gear box

B – Method of pressing packing seal

- use of compression packing seal with cup springs to provide constant pressure force on the packing is preferred when operating with cyclic pulsations of pressure or at high pressures and temperatures

C – Bonnet design

- self-sealing bonnet is used for high pressure, high temperature and for cases with cyclic pulsations of pressure
- the bonnet is connected to body with bolts
- the bonnet is welded to body

D - Connection to pipeline

- flanged
- welded ends according to the customer's specifications

E – Valve plug design

- flat sealing surface
- conical sealing surface

F – Installation of stem nut

- depending on the drive moment, the following is used:
- stem nut is screwed into bonnet
- combination of bushing and bearing
- installation on two axial thrust bearings

G- Design of packing seal

- standard
- double packing with spacer - used according to operating conditions

H – Design of swing check valve

- threaded bushing in the bonnet
- integral with the bonnet

I–Bonnet sealing

- male/female
- self-sealing bonnet

J – Connection of plug with stem

- balls embedded in the spool
- split ring mounted on the stem and threaded sleeve
- screwed into the spool

K –Seat design

- seat screwed into the body
- seat made by welding on the body
- seat sealing surface is flat or conical depending on fluid pressure

GLOBE VALVES

TYPE V30

MATERIAL SPECIFICATION - CAST

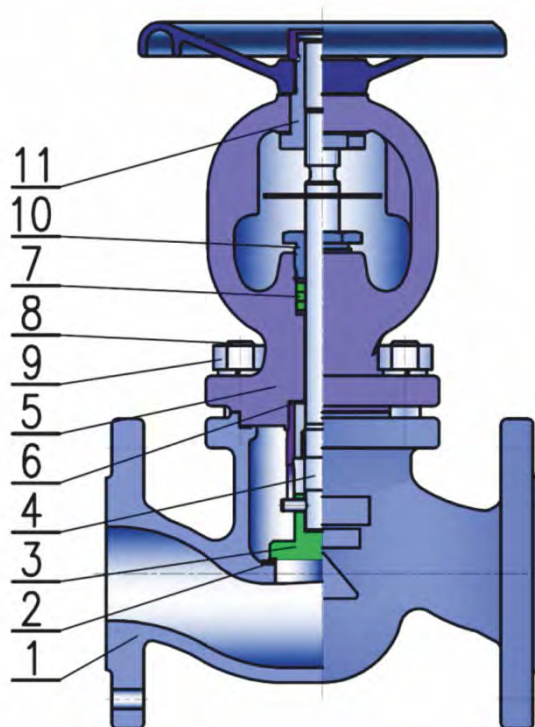

ITEM	NAME	MATERIAL				
1	BODY	GP240GH (1.0619)	42 2643 (GS-42)	42 2942 (1.4410)	42 2745 (GS17CrMo 18 9)	G17CrMo5-5 (1.7357), 13CrMo44(1 .7335)
2	SEAT	Surfacing				
3	PLUG	P265GH, P250GH+sur facing	P265GH, 17 027 + surfacing	42 2942, 17348 + surfacing	42 2745, 17 027+ surfacing	G17CrMo5-5 (1.7357) + surfacing
4	STEM	X20Cr13 (1.4021)	17 027	17 348	15 320	X22CrMoV1 2-1 (1.4923)
5	BONNET	GP240GH (1.0619)	42 2643 (GS-42)	42 2942 (1.4410)	42 2745 (GS17CrMo 18 9)	G17CrMo5-5 (1.7357), 13CrMo44 (1.7335)
6	BACK SEAT	Surfacing				
7	PACKING	Graphite				
8	BOLT	8.8, 21CrMoV5-7 (1.7709)	15 236	1.01	15 236	21CrMoV5-7 (1.7709)
9	NUT	6, 25CrMo4 (1.7218)	6	1.01	15 233	21CrMoV5-7 (1.7709)
10	PACKING BUSH	1.0619	17 027	17 348	17 027	X22CrMoV1 2-1 (1.4923)
11	STEM NUT	Bronze				

GLOBE VALVES

TYPE V30

DIMENSIONS - CAST

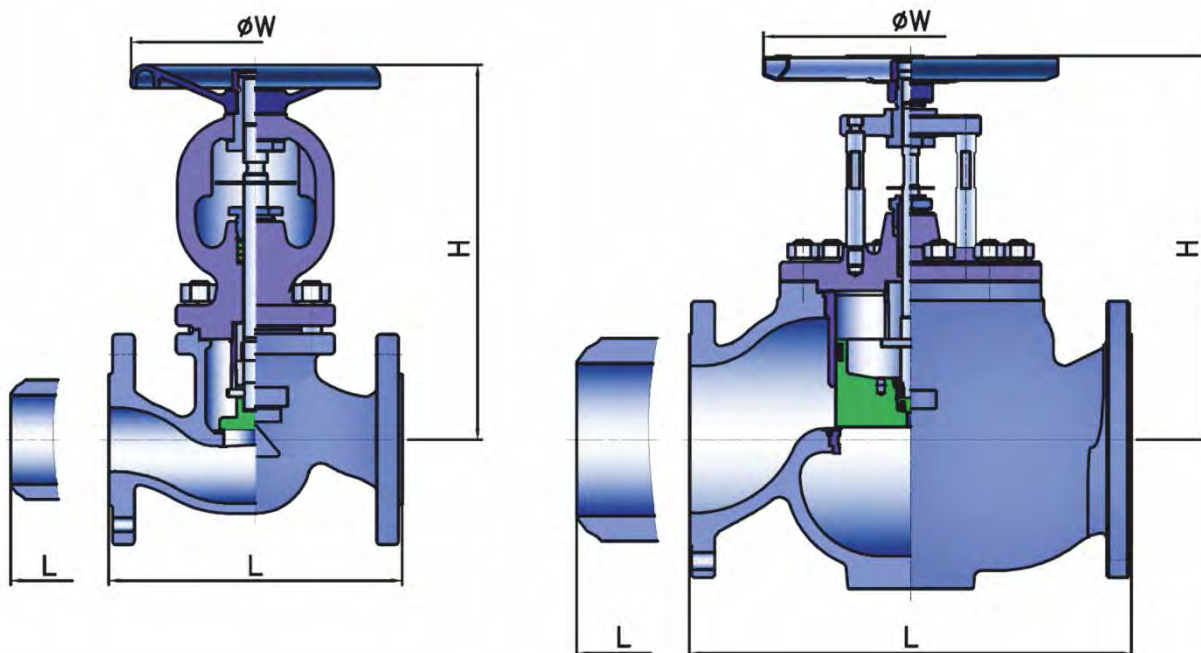

DN	PN 16,25,40				PN 63				PN 100				PN 160			
	L	ØW	H	Mass (kg)	L	ØW	H	Mass (kg)	L	ØW	H	Mass (kg)	L	ØW	H	Mass (kg)
6	130	120	189	2,2	-	-	-	-	-	-	-	-	-	-	-	-
10	130	120	189	2,5	-	-	-	-	-	-	-	-	-	-	-	-
15	130	120	189	4,3	-	-	-	-	-	-	-	-	-	-	-	-
20	150	120	189	5,1	-	-	-	-	-	-	-	-	-	-	-	-
25	160	120	189	5,8	-	-	-	-	-	-	-	-	-	-	-	-
32	180	160	220	9,5	-	-	-	-	-	-	-	-	-	-	-	-
40	200	160	220	9,8	-	-	-	-	-	-	-	-	-	-	-	-
50	230	195	220	17,5	300	250	220	32	300	250	360	34	300	250	340	35
65	290	195	295	20,5	340	315	295	45	340	315	408	49	340	315	408	50
80	310	280	368	34	380	400	368	57	380	400	459	63	380	400	459	64
100	350	280	368	44	430	400	368	83	430	400	484	94	430	400	484	95
125	400	350	523	77	500	500	523	110	500	500	538	123	500	500	538	125
150	480	350	523	110	550	500	523	170	550	500	580	181	550	500	580	183
200	600	350	605	240	650	500	605	240	650	500	705	258	650	600	705	270
250	730	350	663	410	-	-	-	-	-	-	-	-	-	-	-	-
300	850	350	713	610	-	-	-	-	-	-	-	-	-	-	-	-
400	1100	350	855	1240	-	-	-	-	-	-	-	-	-	-	-	-

GLOBE VALVES

TYPE V30

MATERIAL SPECIFICATION - FORGED

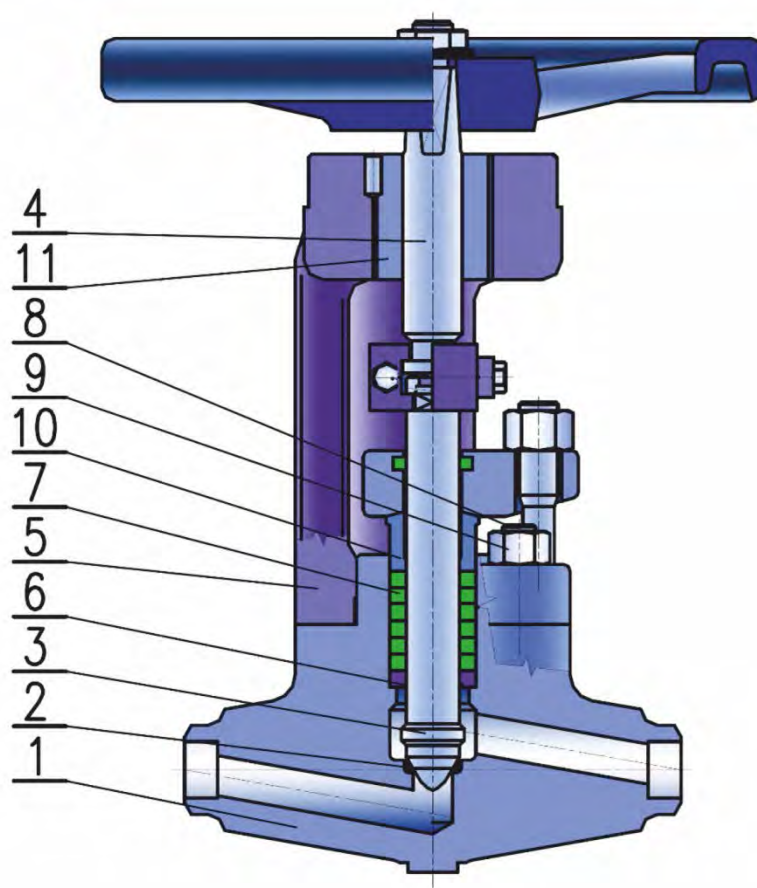

ITEM	NAME	MATERIAL						
1	BODY	P 250 GH, C22.8, (1.0460)	16Mo3 (1.5415)	13CrMo4-5 (1.7335)	11CrMo9-10	14MoV6-3 (1.7715)	X10CrMoVNb9-1 (1.4903)	X6CrNiMoTi17-12-2 (1.4571)
2	SEAT	Surfacing						
3	PLUG	X20Cr13 + surfacing	X22CrMoV12-1(1.7379) + surfacing					X6CrNiMoTi17-12-2 + surfacing
4	STEM	X20Cr13	X22CrMoV12-1 (1.7379)					X6CrNiMoTi17-12-2
5	BONNET	X22CrMoV12-1 (1.4923)						GX5CrNiMo19-11-2
6	BACK SEAT	Surfacing						
7	PACKING	Graphite						
8	BOLT	21CrMoV5-7						A2-70
9	NUT	25CrMo4 (1.7218))						A2
10	PACKING BUSH	X20Cr13	X22CrMoV12-1 (1.7379)					X6CrNiMoTi17-12-2
11	STEM NUT	C 45 (1.0503)						Bronze

GLOBE VALVES

TYPE V30

DIMENSIONS - FORGED

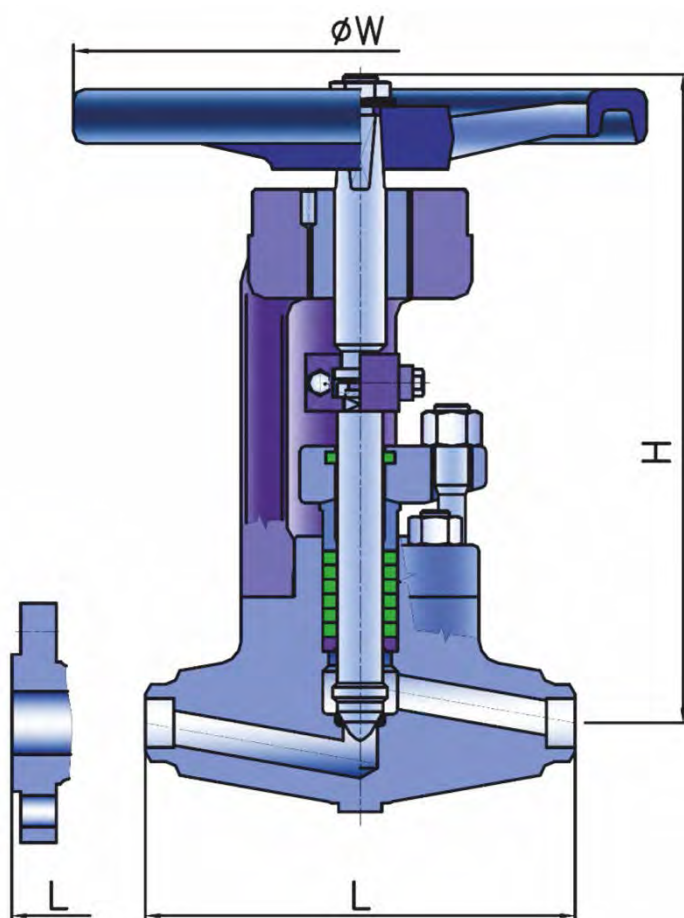

DN	PN 63, 100, 160, 250					PN 250, 320, 400				
	L		ØW	H	Mass (kg)	L		ØW	H	Mass (kg)
	RF	BW				RF	BW			
10	230	150	200	225	10	230	150	200	225	10
15	230	150	200	225	10,9	230	150	200	225	10,9
20	260	160	250	240	14	260	160	250	240	14
25	260	160	250	240	14,5	260	250	250	240	14,5
32	390	250	250	320	27	390	250	355	320	27
40	390	250	250	320	29	390	250	355	320	32
50	390	250	250	320	31	390	250	355	320	36

TYPE DESIGNATION

V30 AC/DE M₁ PN/S

A BODY DESIGN

- 1 Direct

E CONTROL

- 1 Hand wheel
- 2 Gearbox + hand wheel
- 3 Electric actuators
- 4 Gearbox + electric actuators
- 5 Pneumatic actuators
- 9 Without control

S SPECIAL EXECUTION

- As Antistatic
- R With regulating plug

C CONNECTION INTO PIPE

- 1 Flanged
- 2 Welded
- 8 Combined

M₁ BODY MATERIAL

- 0 Stainless steel
- 2 Cast alloy steel
- 3 Forged alloy steel
- 4 Forged carbon steel
- 5 Cast carbon steel
- LT Carbon steel for low temperatures

D FLANGE FACING

FLANGES BY EN 1092 - 1

- A Flat face
- B Raised face
- C Tongue face
- D Groove face
- E Spigot
- F Recess
- G O - ring recess
- H O - ring groove





Range DN: 6 ~ 150
NPS: 1/4" ~ 6"



Range PN: 160 ~ 320
Class: 900 ~ 2500



PED 97/23/EC
PED 2014/68/EU



TR TS 10/11,
12/11, 32/11



EN 12 569
CERTIFICATE



HIGH-PRESSURE
EXECUTION

Operating temperature: -196 °C ~ 550 °C

Connection into piping: Flanged, welded ends, combined execution



DESCRIPTION

GLB valves are controlled shut-off valves. They are designed to stop or allow the flow of the medium by external operation, via either the handwheel or the installed drive.

If, upon the customer's request, they are fitted with a regulating cone, they can be used to regulate the flow of the medium. The medium can flow in one direction only. These valves are designed and manufactured to ensure maximum service life and reliability.

MATERIAL SPECIFICATION

GLB valves are made from carbon, alloy and stainless steels. The material type can be adjusted according to the customer's request to optimally suit the operating conditions.

APPLICATION

GLB valves are made from carbon, alloy and stainless steels. The material type can be adjusted according to the customer's request to optimally suit the operating conditions..

BASIC STANDARDS FOR DESIGN

Basic design

EN 12 516 -1, 2

Pressure-temperature rating

ASME B16.34, EN 12 516 - 1

Testing

API 598, EN 12 266 - 1, 2

Face-to-face dimensions

See the table of dimensions

Dimensions of the welded ends

ANSI B16.25, EN 12 627

Top Flange dimensions

EN ISO 5210

Flange dimensions

ANSI B 16.5, EN 1092 - 1,
GOST 12815-80, GOST 9399-81

Special

NACE MR-0175

GLOBE VALVES

TYPE GLB

STRUCTURAL DESIGN

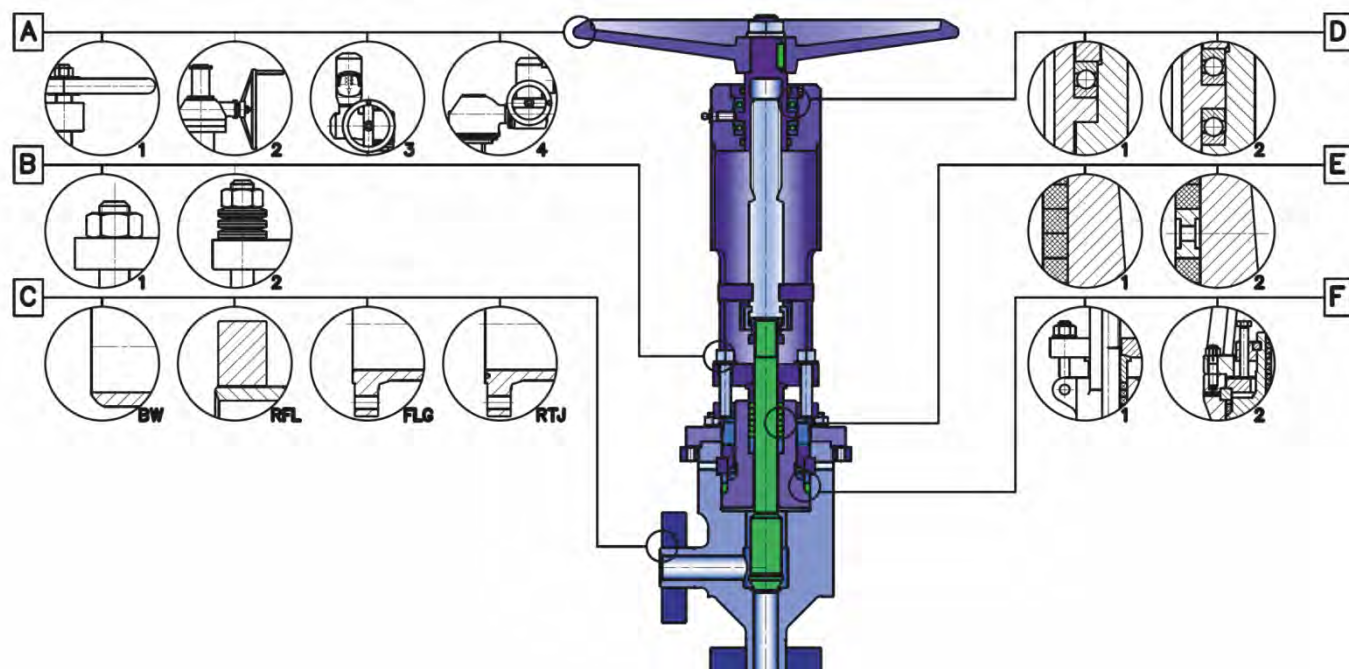

A - Control

- handwheel
- handwheel with gear box
- electric actuator
- electric actuator with gear box

B – Method of pressing packing seal

- use of compression packing seal with cup springs to provide constant pressure force on the packing is preferred when operating with cyclic pulsations of pressure or at high pressures and temperatures

C — Connection into pipe

- flanged
- threaded ends
- welded ends
- welded ends according to the customer specifications

D – Installation of stem nut

- combination of bushing and bearing
- installation on two axial thrust bearings

E — Design of packing seal

- standard
- double packing with spacer - used according to operating conditions

F — Pressure seal bonnet

- pressure seal bonnet is used from DN32 and above

GLOBE VALVES

TYPE GLB

MATERIAL SPECIFICATION

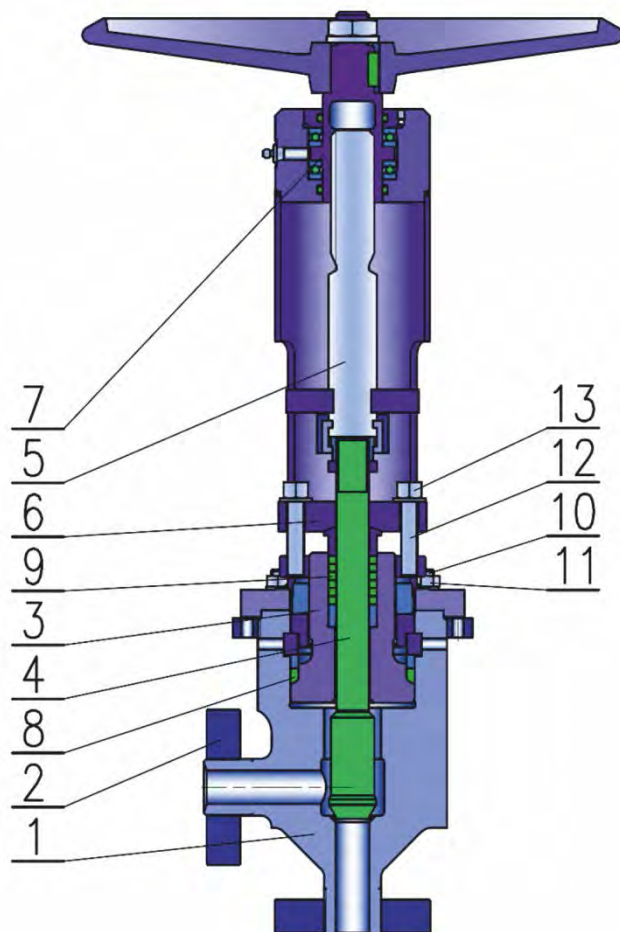

ITEM	NAME	P355 NL1	P355 NL2	1.4541	1.4401	A350 LF2	A105	A182 F5	A182 F304	A182 F316
1	BODY	P355 NL1	P355 NL2	1.4541	1.4401	A350 LF2	A105	A182 F5	A182 F304	A182 F316
2	FLANGE	P355 NL1, P355 NL2, P460 NL2, 1.4541, 1.4401								
3	DISCHARGE COVER	P355 NL1	P355 NL2	1.4541	1.4401	A350 LF2	A105	A182 F5	A182 F304	A182 F316
4	PLUG	1.4541+surfacing								
5	STEM	17 027.6								
6	SEALING FLANGE	P355 NL1	P355 NL2	1.4541	1.4401	A350 LF2	A105	A182 F5	A182 F304	A182 F316
7	STEM NUT	Bronze								
8	SEALING	Graphite								
9	PACKING	Graphite								
10	BOLT	42CrMo4	42CrMo4	A2-70	A2-70	A320 L7	A193 B7	A193 B16	A193 B8	A193 B8M
11	NUT	A2-70	A2-70	A2-70	A2-70	A194 4	A194 2H	A194 2H	A194 8	A194 8M
12	BOLT	42CrMo4	42CrMo4	A2-70	A2-70	A320 L7	A193 B7	A193 B16	A193 B8	A193 B8M
13	NUT	A2-70	A2-70	A2-70	A2-70	A194 4	A194 2H	A194 2H	A194 8	A194 8M

GLOBE VALVES

TYPE V30

DIMENSIONS

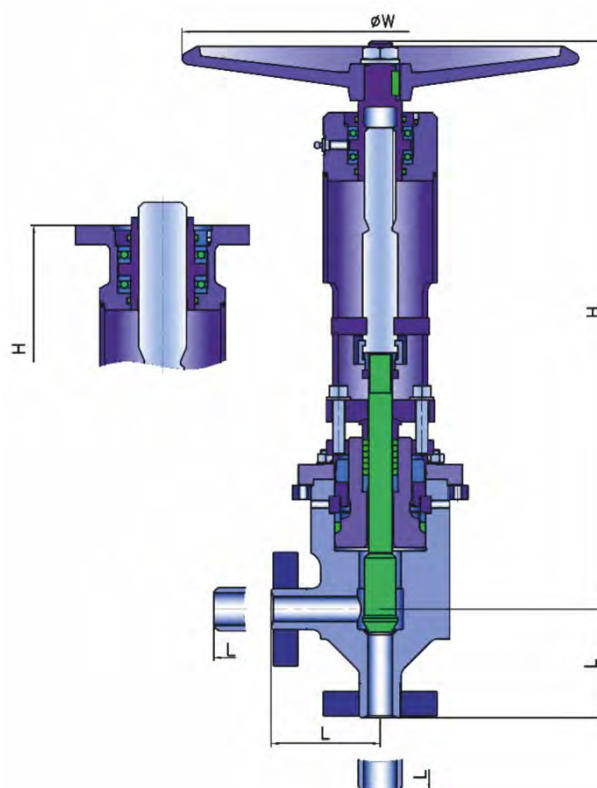

DN	PN 160					PN 250					PN 320				
	1	2	H	W	Mass (kg)	1	2	H	W	Mass (kg)	1	2	H	W	Mass (kg)
6	105	60	203	100	6	115	60	203	100	7	115	60	203	100	8
10	105	80	246	100	8	115	80	246	160	10	115	85	246	160	11
15	105	80	410	160	24	115	108	410	200	24	115	132	410	250	27
25	115	127	575	200	42	130	127	575	250	54	130	154	575	400	61
40	130	152	550	250	63	150	152	550	350	72	150	192	550	-	85
50	150	184	600	350	77	175	184	600	500	110	175	225	600	-	138
65	170	210	625	500	136	200	210	625	500	161	200	254	625	-	192
80	190	190	720	500	157	225	235	720	500	265	225	289	720	-	285
100	215	229	850	500	270	260	273	850	600	426	260	337	850	-	470
125	250	279	1000	600	435	300	337	1000	700	638	300	-	1000	-	695
150	275	305	1450	600	594	350	352	1450	700	860	350	-	1450	-	922

NPS	CLASS 900					CLASS 1500					CLASS 2500				
	1	2	H	W	Mass (kg)	1	2	H	W	Mass (kg)	1	2	H	W	Mass (kg)
1/2	115 / 114	108	280	200	10	130 / 114	108	350	200	10	132	108	350	250	10
1	130 / 127	127	340	200	15	130 / 127	127	400	200	15	150	127	400	400	16
1 1/2	150 / 152	152	400	300	25	150 / 152	152	500	300	25	192	152	500	500	41
2	170 / 184	184	500	400	85	175 / 184	184	600	400	85	225	184	600	630	91
2 1/2	215 / 210	210	550	500	95	215 / 210	210	700	500	95	254	210	700	710	112
3	225 / 190	190	600	630	120	225 / 235	235	800	630	120	289	235	950	710	144
4	250 / 229	229	700	630	155	250 / 273	273	900	630	155	337	273	1200	800	186
5	325 / 280	279	800	710	230	325 / 337	337	1000	710	230	-	-	-	-	-
6	400 / 305	305	900	710	280	400 / 352	352	1100	710	280	-	-	-	-	-

TYPE DESIGNATION

GLB AC/D E M₁ PN or Class

A BODY DESIGN

- 1 Direct
- 2 Angular
- Z Z-shape

E CONTROL

- 1 Handwheel
- 2 Gear box + handwheel
- 3 Electric actuator
- 5 Pneumatic actuator
- 9 Without control

M₁ BODY MATERIAL

- 0 Stainless steel
- 3 Forged alloy steel
- 4 Forged carbon steel
- LT Carbon steel for low temperatures

C CONNECTION INTO PIPE

- 1 Flanged
- 2 Welded
- 6 Threaded flange

D FLANGE FACING

EN 1092 - 1

- A Flat face
- B Raised face
- C Tongue face
- D Groove face
- E Spigot
- F Recess
- G O - ring recess
- H O - ring groove

ANSI B 16.5

- PFF Flat sealing face
- RF Raised face
- LTF Large tongue
- STF Small tongue
- LGF Large groove
- SGF Small groove
- LMF Large male
- SMF Small male
- LFF Large female
- SFF Small female
- RTJ Ring joint

GOST / DIN

- L Lens





Range NPS: 1/4" ~ 12"



PED 97/23/EC
PED 2014/68/EU



TR TS 10/11,
12/11, 32/11



Range Class: 150 ~ 2500

Operating temperature: -196 °C ~ 550 °C

Connection into piping: Flanged, welded ends, threaded ends, combined execution

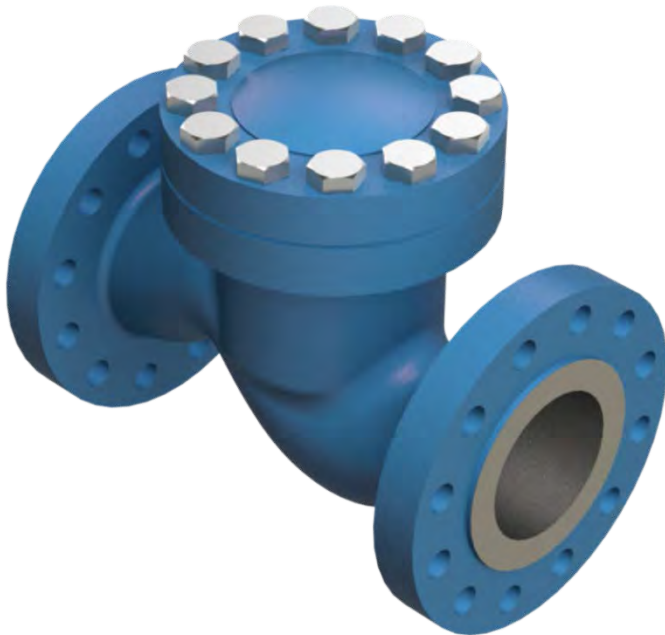

DESCRIPTION

The lift check valves are automatic check valves. They automatically prevent the reverse flow of the medium. The medium can flow in one direction only. These valves are designed and manufactured to ensure maximum service life and reliability acc. to API standards.

MATERIAL SPECIFICATION

The valve parts that work under pressure, i.e., body, bonnet and plug are made of unalloyed or alloyed steels intended for casting. The material is selected depending on the characteristics of the process medium and operating temperature.

APPLICATION

The lift check valves can be used for water (except drinking water), steam, oil, air, hydrocarbons, petroleum and oil products.

BASIC STANDARDS FOR DESIGN

Basic design

API 602, API 6D, ASME B16.34

Pressure-temperature rating

ASME B16.34

Testing

API 598, EN 12 266 - 1, 2

Face-to-face dimensions

ANSI B16.10

Dimensions of the welded ends

ANSI B16.25

Top Flange dimensions

EN ISO 5210

Flange dimensions

ANSI B 16.5

Special

NACE MR-0175

LIFT CHECK VALVES

TYPE C09 3

MATERIAL SPECIFICATION

ITEM	NAME	MATERIAL	
1	BODY	A352 LCB, A352 LCC, A216	A351 CF8, A351 CF8M, A182 F304, A182 F316
2	BONNET	WCB, A350 LF2, A105	F304, A182 F316
3	BODY SEAT PLUG SEAT	18-8-Cr Ni 13Cr, 17Cr, Stl.6	
4	PLUG	A352 LCB, A352 LCC, A216 WCB, A350 LF2, A105	A351 CF8, A351 CF8M, A182 F304, A182 F316
5	SLEEVE	A182 F304, A182 F316	
6	PLUG GUIDE		
7	BONNET STUD	A320 L7, A194 B7	A193 B8
8	NUT	A194 4, A194 2H	A194 8
9	SPRING	STAINLESS STEEL	

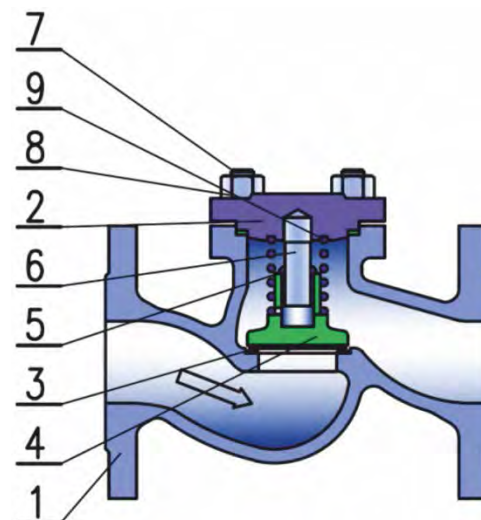

DIMENSIONS – DIRECT EXECUTION

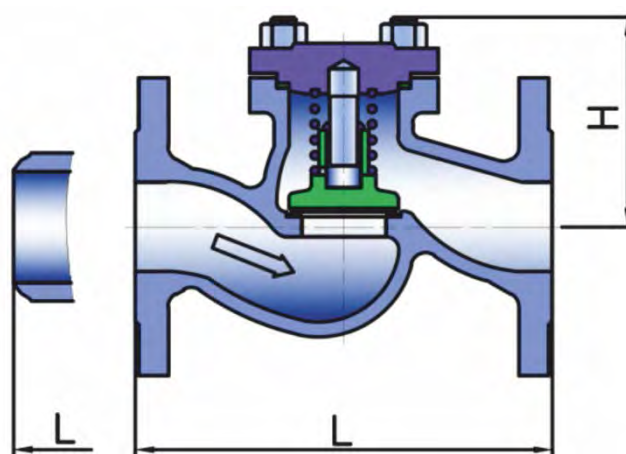

NPS	CLASS 150				CLASS 300				CLASS 600				CLASS 900			
	L		H	Mass (kg)	L		H	Mass (kg)	L		H	Mass (kg)	L		H	Mass (kg)
	1/RF	2			1/RF	2			1/RF	2			1/RF	2		
3/8	102	102	76	1,8	152	152	78	2,2	-	-	-	-	-	-	-	-
1/2	108	108	76	2,2	152	152	78	3	-	-	-	-	-	-	-	-
3/4	117	117	76	3,6	178	178	82	5	-	-	-	-	-	-	-	-
1	127	127	98	5	203	203	102	7	-	-	-	-	-	-	-	-
1 1/2	165	165	115	7,5	229	229	118	10	-	-	-	-	-	-	-	-
2	203	203	140	9,5	267	267	140	13	292	292	152	14,3	368	368	180	15,5
3	241	241	168	16	318	318	178	21	356	356	178	25	381	381	235	35
4	292	292	194	20	356	356	195	29	432	432	215	33	457	457	270	42
6	406	406	226	31	445	445	245	43	559	559	279	57	610	610	350	65
8	495	495	250	67	559	559	280	98	660	660	328	118	737	737	400	150
10	622	622	275	152	622	622	336	188	-	-	-	-	-	-	-	-
12	698	698	332	180	711	711	380	222	-	-	-	-	-	-	-	-

LIFT CHECK VALVES

TYPE C09 3

DIMENSIONS – OBLIQUE EXECUTION

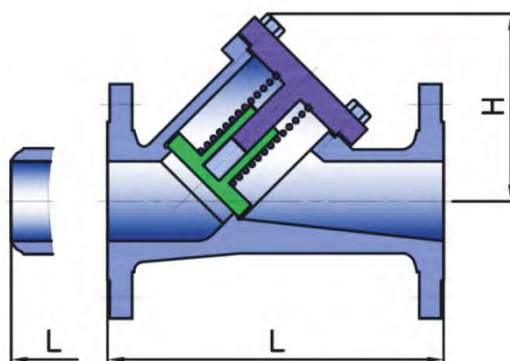

NPS	CLASS 150				CLASS 300				CLASS 600				CLASS 900			
	L		H	Mass (kg)	L		H	Mass (kg)	L		H	Mass (kg)	L		H	Mass (kg)
	1/RF	2			1/RF	2			1/RF	2			1/RF	2		
3/8	102	102	76	1,8	152	152	78	2,2	-	-	-	-	-	-	-	-
1/2	108	108	76	2,2	152	152	78	3	-	-	-	-	-	-	-	-
3/4	117	117	76	3,6	178	178	82	5	-	-	-	-	-	-	-	-
1	127	127	98	5	203	203	102	7	-	-	-	-	-	-	-	-
1 1/2	165	165	115	7,5	229	229	118	10	-	-	-	-	-	-	-	-
2	203	203	140	9,5	267	267	140	13	292	292	152	14,3	368	368	180	15,5
3	241	241	168	16	318	318	178	21	356	356	178	25	381	381	235	35
4	292	292	194	20	356	356	195	29	432	432	215	33	457	457	270	42
6	406	406	226	31	445	445	245	43	559	559	279	57	610	610	350	65
8	495	495	250	67	559	559	280	98	660	660	328	118	737	737	400	150
10	622	622	275	152	622	622	336	188	-	-	-	-	-	-	-	-
12	698	698	332	180	711	711	380	222	-	-	-	-	-	-	-	-

DIMENSIONS – FORGED

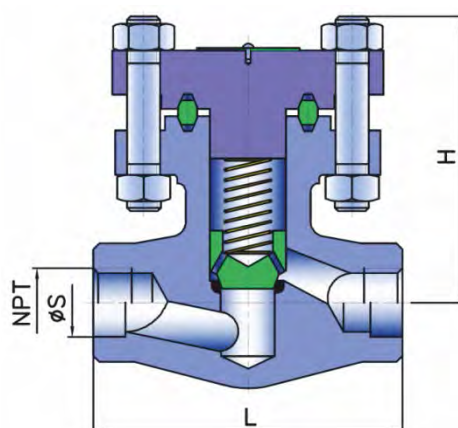

NPS	DN	CLASS 800						CLASS 1500						CLASS 2500					
		L		NPT	S	H	BEC (KG)	L		NPT	S	H	BEC (KG)	L		NPT	S	H	BEC (KG)
		3	4					3	4					3	4				
1/4	6	80	80	1/4	14,2	55	1,3	110	110	1/4	14,2	96	3,2	150	150	1/4	14,2	128	7,5
3/8	10	80	80	3/8	17,6	55	1,3	110	110	3/8	17,6	96	3,2	150	150	3/8	17,6	128	7,5
1/2	15	80	80	1/2	21,8	55	1,3	110	110	1/2	21,8	96	3,2	150	150	1/2	21,8	128	7,5
3/4	20	90	90	3/4	27,2	60	1,6	150	150	3/4	27,2	128	7,3	150	150	3/4	27,2	128	7,5
1	25	110	110	1	33,9	78	2,8	150	150	1	33,9	128	7,3	210	210	1	33,9	152	18,5
1 1/2	40	150	150	1 1/2	48,8	92	5,6	210	210	1 1/2	48,8	155	17	230	230	1 1/2	48,8	190	30
2	50	180	180	2	61,2	108	9,0	230	230	2	61,2	195	29	230	230	2	61,2	190	30

 TYPE DESIGNATION
C09 3 AC/DE M₁ CLASS/S**A** BODY DESIGN

- 1 Direct
- S Oblique

E CONTROL

- 7 automatic

S SPECIAL EXECUTION

- As Antistatic

C CONNECTION INTO PIPE

- 1 Flanged
- 2 Welded ends
- 3 Threaded
- 4 Socket welding
- 8 Combined

M₁ BODY MATERIAL

- 0 Stainless steel
- 2 Cast alloy steel
- 3 Forged alloy steel
- 4 Forged carbon steel
- 5 Cast carbon steel
- LT Carbon steel for low temperatures

D FLANGE FACING**ANSI B 16.5**

- PFF** Flat face
- RF** Raised face
- LTF** Large tongue face
- STF** Small tongue face
- LGF** Large groove face
- SGF** Small groove face
- LMF** Large male face
- SMF** Small male face
- LFF** Large female face
- SFF** Small female face
- RTJ** Ring join face





Range DN: 50 ~ 150
NPS: 2" ~ 6"



Range PN: 16 ~ 400
Class: 900 ~ 2500



PED 97/23/EC
PED 2014/68/EU



TR TS 10/11,
12/11, 32/11



**HIGH-PRESSURE
EXECUTION**

Operating temperature: -196 °C ~ 550 °C

Connection into piping: Flanged, welded ends, threaded ends, combined execution



DESCRIPTION

PSG valves are automatic check valves manufactured in two versions:

1. Check valve for vertical pipes, with automatic overflow – designed to protect the pump against the effects of the recoil caused by the transported medium by overflowing it.
2. Check valve for vertical pipes, without overflow - designed to protect the pump against the effects of the recoil caused by the transported medium by stopping it. These valves are designed and manufactured to ensure maximum service life and reliability.

These valves are designed and manufactured to ensure maximum service life and reliability.

MATERIAL SPECIFICATION

PSG lift check valves are made from carbon, alloy and stainless steels. The material type can be adjusted according to the customer's request to optimally suit the operating conditions.

APPLICATION

PSG lift check valves are suitable for high-pressure various liquids, gases and steam.

BASIC STANDARDS FOR DESIGN

Basic design

EN 13 709

Pressure-temperature rating

EN 12 516 - 1, ASME B16.34

Testing

API 598, EN 12 266 - 1, 2

Face-to-face dimensions

EN 558, ANSI B16.10

Dimensions of the welded ends

ANSI B16.25

Top Flange dimensions

EN ISO 5210

Flange dimensions

EN 1759-1, EN 1092-1,
GOST: 12821-80, 12815-80, 9399-81

Special

NACE MR-0175

LIFT CHECK VALVES

TYPE PSG

MATERIAL SPECIFICATION

LIFT CHECK VALVE type PSG without automatic overflow for vertical pipeline

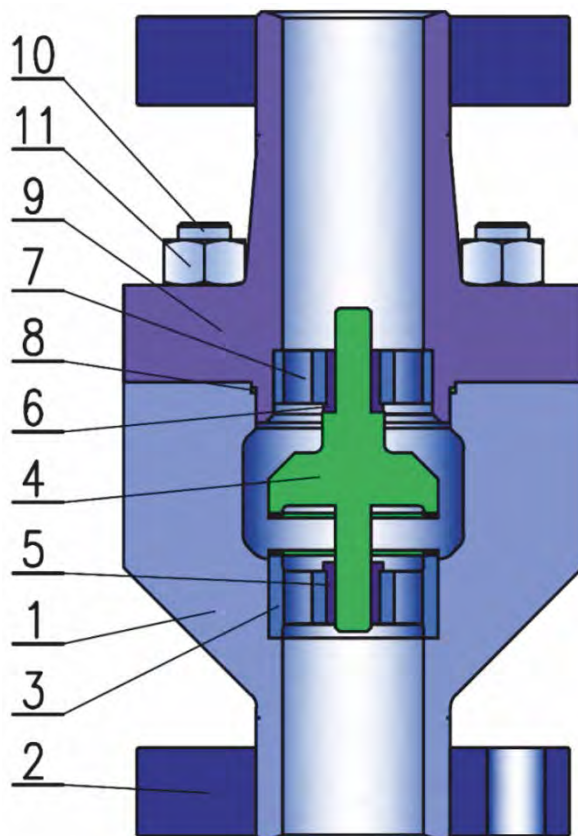

POS.	NAME	MATERIAL									
1	BODY	P355 NH	A350 LF2	A105	1.4541	1.4401	A182 316	A182 F304	A182 316L	A182 F304L	
2	FLANGE	P355 NH	A350 LF2	A105	1.4541	1.4401	A182 316	A182 F304	A182 F316L	A182 F304L	
3	SEAT	P355 NH + surfacing	A350 LF2 + surfacing	A105 + surfacing	1.4541 + surfacing	1.4401 + surfacing	A182 316 + surfacing	A182 F304 + surfacing	A182 F316L + surfacing	A182 F304L + surfacing	
4	PLUG	P355 NH + surfacing	A350 LF2 + surfacing	A105 + surfacing	1.4541 + surfacing	1.4401 + surfacing	A182 316 + surfacing	A182 F304 + surfacing	A182 F316L + surfacing	A182 F304L + surfacing	
5	SLEEVE	CuSn6									
6	SLEEVE	CuSn6									
7	GUIDE	P355 NH	A350 LF2	A105	1.4541	1.4401	A182 316	A182 F304	A182 316L	A182 F304L	
8	SEALING	Graphite									
9	BONNET	P355 NH	A350 LF2	A105	1.4541	1.4401	A182 316	A182 F304	A182 316L	A182 F304L	
10	BOLT	42CrMo4	A320 L7	A193 B7	A2-70	A2-70	A193 B8M	A193 B8	A193 B8M	A193 B8	
11	NUT	42CrMo4	A194 4	A194 2H	A2-70	A2-70	A194 8M	A194 8	A194 8M	A194 8	

LIFT CHECK VALVES

TYPE PSG

MATERIAL SPECIFICATION

LIFT CHECK VALVE type PSG with automatic overflow for vertical pipeline

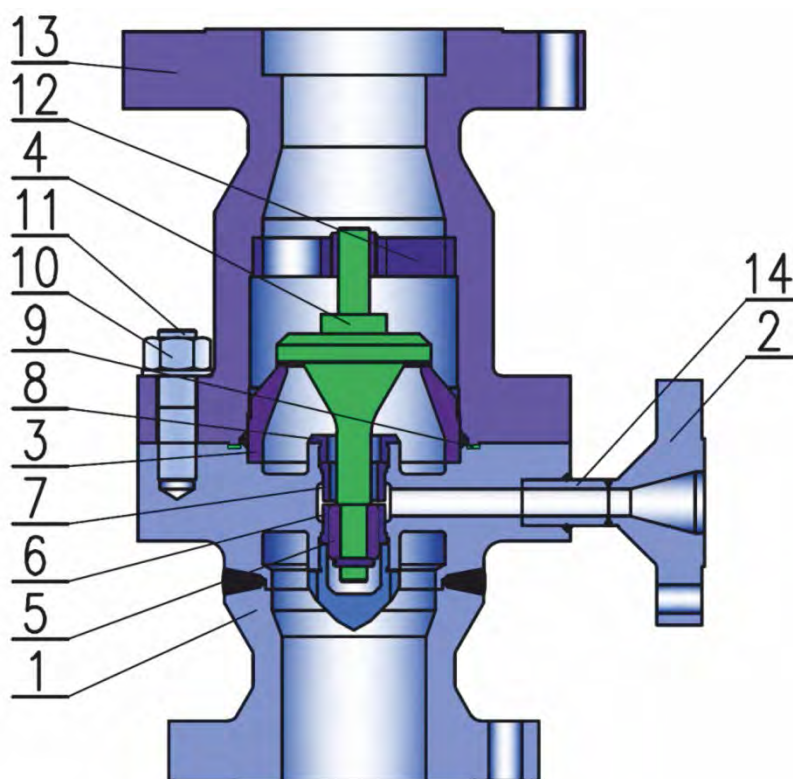

POS.	NAME	MATERIAL								
1	BODY	P355 NH	A350 LF2	A105	1.4541	1.4401	A182 316	A182 F304	A182 316L	A182 F304L
2	FLANGE	P355 NH	A350 LF2	A105	1.4541	1.4401	A182 316	A182 F304	A182 F316L	A182 F304L
3	SEAT	P355 NH + surfacing	A350 LF2 + surfacing	A105 + surfacing	1.4541 + surfacing	1.4401 + surfacing	A182 316 + surfacing	A182 F304 + surfacing	A182 F316L + surfacing	A182 F304L + surfacing
4	PLUG	P355 NH + surfacing	A350 LF2 + surfacing	A105 + surfacing	1.4541 + surfacing	1.4401 + surfacing	A182 316 + surfacing	A182 F304 + surfacing	A182 F316L + surfacing	A182 F304L + surfacing
5	SLEEVE	CuSn6								
6	SLEEVE									
7	SLEEVE	17 027.6								
8	SLEEVE NUT									
9	SEALING	Graphite								
10	NUT	42CrMo4	A194 4	A194 2H	A2-70	A2-70	A194 8M	A194 8	A194 8M	A194 8
11	BOLT	42CrMo4	A320 L7	A193 B7	A2-70	A2-70	A193 B8M	A193 B8	A193 B8M	A193 B8
12	GUIDE	P355 NH	A350 LF2	A105	1.4541	1.4401	A182 316	A182 F304	A182 316L	A182 F304L
13	BONNET	P355 NH	A350 LF2	A105	1.4541	1.4401	A182 316	A182 F304	A182 316L	A182 F304L
14	TUBE	P355 NH	A350 LF2	A105	1.4541	1.4401	A182 316	A182 F304	A182 316L	A182 F304L

LIFT CHECK VALVES

TYPE PSG

DIMENSIONS

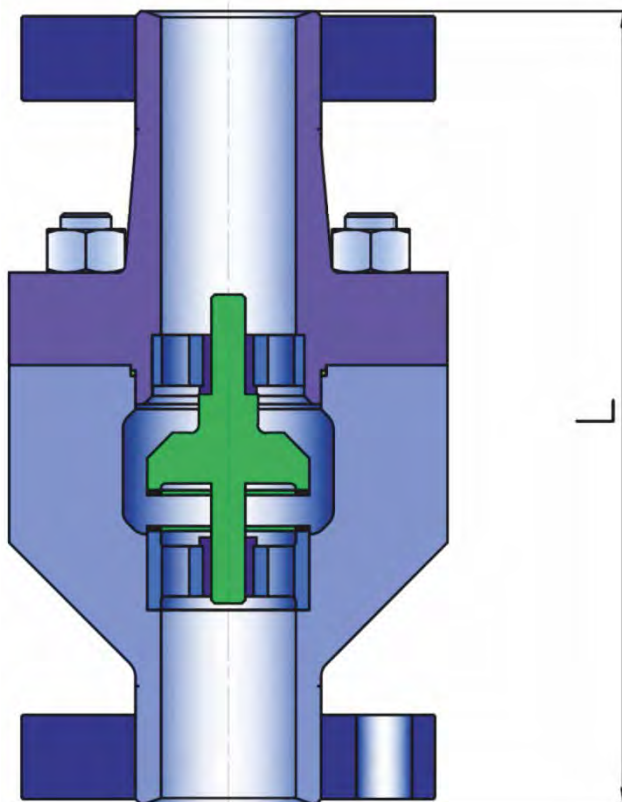

NPS	DN	CLASS 600		CLASS 900		CLASS 1500-2500		PN 100		PN 160		PN 250-400	
		L	Mass (kg)	L	Mass (kg)	L	Mass (kg)	L	Mass (kg)	L	Mass (kg)	L	Mass (kg)
2	50	292	47	368	65	451	76	250	40	300	47	350	50
2 ½	65	330	72	391	93	508	109	290	63	360	72	425	80
3	80	356	136	419	172	578	198	310	128	390	140	470	155
4	100	432	273	457	302	673	343	350	230	450	263	550	282
5	125	508	338	559	398	794	454	400	293	525	327	650	365
6	150	559	466	610	544	914	615	450	398	600	459	750	486

 TYPE DESIGNATION

PSG B C D E M₁ PN or Class/S
B BODY DESIGN

- 2 Two pieces
- 3 Three pieces

C CONNECTION INTO PIPE

- 1 Flanged
- 2 Threaded

D FLANGE FACING
EN 1092-1

- A Flat face
- B Raised face
- C Tongue face
- D Groove face
- E Spigot
- F Recess
- G O - ring recess
- H O - ring groove

GOST 9399-81

- L For lens gasket

ANSI B 16.5

- PFF Flat sealing face
- RF Raised face
- LTF Large tongue
- STF Small tongue
- LGF Large groove
- SGF Small groove
- LMF Large male
- SMF Small male
- LFF Large female
- SFF Small female
- RTJ Ring joint

E CONTROL

- 7 Automatic

M₁
BODY MATERIAL

- 0 Stainless steel
- 3 Forged alloy steel forged
- 4 Forged carbon steel
- LT Carbon steel for low temperatures

S SPECIAL EXECUTION

- As Antistatic
- O with overflow





Range DN: 15 ~ 300
NPS: 1/2" ~ 8"



PED 97/23/EC
PED 2014/68/EU



TR TS 10/11,
12/11, 32/11



Range PN: 6 ~ 160
Class: 150 ~ 900

Operating temperature: -196 °C ~ 550 °C

Connection into piping: WAFER

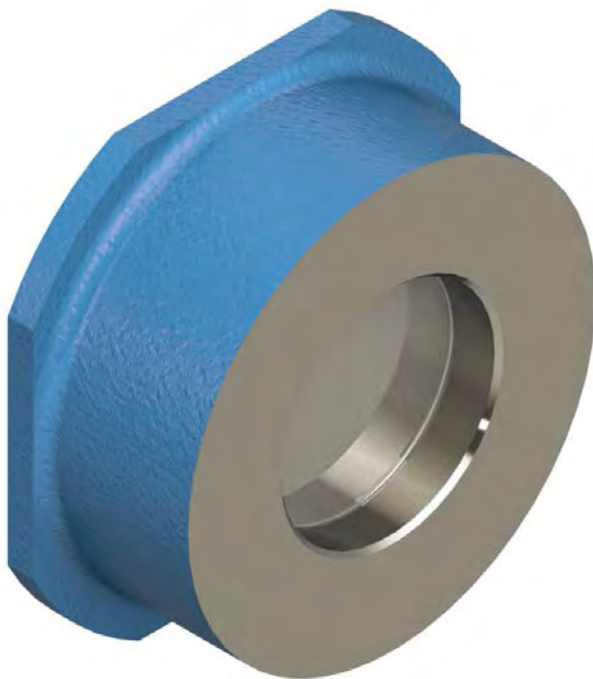

DESCRIPTION

WA-001 wafer disc check valves are automatic check valves. They automatically prevent the reverse flow of the medium. The medium can flow in one direction only. These check valves are designed and manufactured to ensure maximum service life and reliability.

MATERIAL SPECIFICATION

WA-001 wafer disc check valves are made from carbon, alloy and stainless steels. The material type can be adjusted according to the customer's request to optimally suit the operating conditions.

APPLICATION

WA-001 wafer disc check valves are specially designed for use in the hydraulic and pneumatic systems, but they are suitable for various liquids, gases and steam.

BASIC STANDARDS FOR DESIGN

Basic design

EN 12 516 - 1

Pressure-temperature rating

EN 12 516 - 1

Testing

EN 12 266 - 1, 2

Face-to-face dimensions

EN 558

Dimensions of the welded ends

None

Top Flange dimensions

None

Sealing surface execution

EN 1759-1, EN 1092-1

Special

NACE MR-0175

WAFER DISC CHECK VALVES

TYPE WA-001

MATERIAL SPECIFICATION

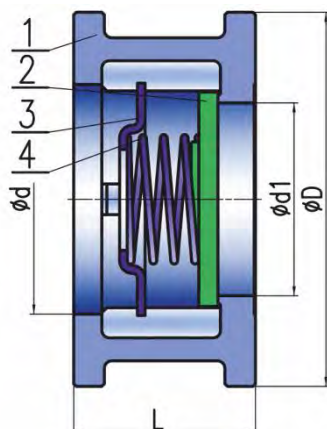
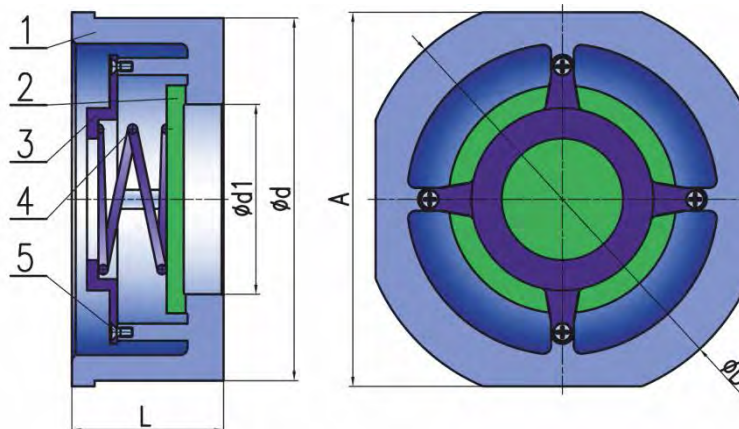
EXECUTION CLASS

EXECUTION PN

Pos.	Designation	Material			
		Acc to EN standards		Acc to ASTM standards	
		material designation	standard	material designation	standard
1	Body	1.4408 (GX5CrNiMo19-11-2)	EN 10213-4	CF3, CF8M	A351
		1.4308 (GX5CrNi19-10)	EN 10272	CF8	
2	Disc	1.4436 (X3CrNiMo17-13-3)	EN 10228-7	F 316	A182
		1.4301 (X5CrNi18-10)	EN 10272	SS 304	AISI 304
3	Bonnet	1.4408 (GX5CrNiMo19-11-2)	EN10028-7	CF3, CF8M	A351
		1.4301 (X5CrNi18-10)	EN 10272	SS 304	AISI 304
4	Spring	1.4436 (X3CrNiMo17-13-3)	EN 10272	F 316	A182
		1.4301 (X5CrNi18-10)		SS 304	AISI 304
5	Bolt	1.4301 (X5CrNi18-10)	EN 10272	SS 304	AISI 304

DIMENSIONS – EXECUTION PN

DN	PN 6 ÷ 15						PN 25					PN 40				
	d1	d	A	D	L	(KG)	d1	d	D	L	(KG)	d1	d	D	L	(KG)
15	15	43	45	53	16,5	0,17	15	45	53	16,5	0,17	15	45	53	16,5	0,17
20	20	46	55	63	19,5	0,19	20	55	63	19,5	0,19	20	55	63	19,5	0,19
25	25	63	65	73	22	0,3	25	65	73	22	0,3	25	65	73	22	0,3
32	30	75	78	84	28	0,4	30	78	84	28	0,4	30	78	84	28	0,4
40	38	83	88	94	32	0,6	38	88	94	32	0,6	38	88	94	32	0,6
50	47	95	98	107	40	0,85	47	98	107	40	0,85	47	98	107	40	0,85
65	62,5	115	118	126	46	1,5	62,5	118	126	46	1,5	62,5	118	126	46	1,5
80	77	130	134	144	50	1,76	77	134	144	50	1,76	77	134	144	50	1,76
100	96	151	154	164	60	3,3	96	154	170	60	4,2	96	154	170	60	4,2
125	110	178	184	194	90	9	110	180	196	90	10	110	180	196	90	10
150	127	200	209	220	106	14	127	205	226	106	16	127	205	226	106	16
200	165	254	264	275	140	24	165	265	284	140	28	165	275	296	140	29
250	205	305	319	330	200	30	205	315	343	200	35	205	325	355	200	36
300	238	360	375	380	250	42	238	375	403	250	45	238	395	420	250	48

WAFER DISC CHECK VALVES

TYPE WA-001

DIMENSIONS – EXECUTION CLASS

NPS	DN	CLASS 150					CLASS 300					CLASS 600					CLASS 900				
		d1	d	D	L	(KG)	d1	d	D	L	(KG)	d1	d	D	L	(KG)	d1	d	D	L	(KG)
1/2	15	15	25	46	25	0,28	15	25	52	25	0,3	15	25	52	25	0,4	15	25	62	25	0,6
3/4	20	19	30	56	31,5	0,42	19	30	65	31,5	0,46	19	30	65	31,5	0,8	19	30	69	31,5	0,9
1	25	24	36	65	35,5	0,56	24	36	72	35,5	0,6	24	36	72	35,5	1	24	36	77	35,5	1,2
1 1/4	32	31	43	74	40	0,75	31	43	81	40	0,8	31	43	81	40	1,3	31	43	87	40	1,5
1 1/2	40	39	52	84	45	1,3	39	52	94	45	1,5	39	52	94	45	1,8	39	52	97	45	2
2	50	48	62	103	56	2,1	48	62	110	56	2,4	48	62	110	56	2,8	48	62	140	56	5,5
2 1/2	65	62	75	122	63	2,8	62	75	128	63	3	62	75	128	63	4	62	75	162	63	7,5
3	80	76	90	135	71	3,6	76	90	147	71	4	76	90	147	71	6	76	90	165	71	8
4	100	95	112	173	80	4,8	95	112	179	80	5,5	95	112	191	80	11	95	112	204	80	14
5	125	110	132	195	110	12	110	132	214	110	13	110	132	239	110	25	110	132	245	110	27
6	150	127	158	220	125	17	127	158	249	125	22	127	158	264	125	32	127	158	286	125	41
8	200	165	208	277	160	29	165	208	305	160	36	165	208	318	160	52	165	208	356	160	76

TYPE DESIGNATION

WA-001 DN PN or Class/S

S
SPECIAL VARIATIONS
As antistatic execution



Range DN: 10 ~ 300



Range PN: 16 ~ 100



PED 97/23/EC
PED 2014/68/EU



TR TS 10/11,
12/11, 32/11



EN 12 569
CERTIFICATE

Operating temperature: -196 °C ~ 550 °C

Connection into piping: Flanged, welded ends, threaded ends, combined execution

DESCRIPTION

Z15 lift check valves are automatic check valves. They automatically prevent the reverse flow of the medium. The medium can flow in one direction only. These valves are designed and manufactured to ensure maximum service life and reliability.

MATERIAL SPECIFICATION

Z15 lift check valves are made from carbon, alloy and stainless steels. The material type can be adjusted according to the customer's request to optimally suit the operating conditions.

APPLICATION

Z15 lift check valves are suitable for various liquids, gases and steam.

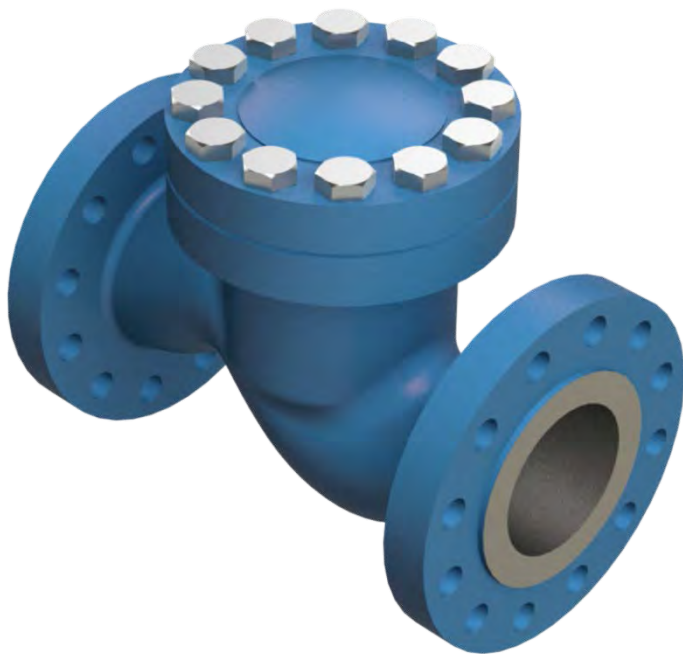

BASIC STANDARDS FOR DESIGN

Basic design

EN 13 709

Pressure-temperature rating

EN 12 516 - 1

Testing

EN 12 266 - 1, 2

Face-to-face dimensions

EN 558, EN 12 982

Dimensions of the welded ends

EN 12 627

Top Flange dimensions

None

Flange dimensions

EN 1092 - 1

Special

NACE MR-0175

LIFT CHECK VALVES

TYPE Z15

MATERIAL SPECIFICATION

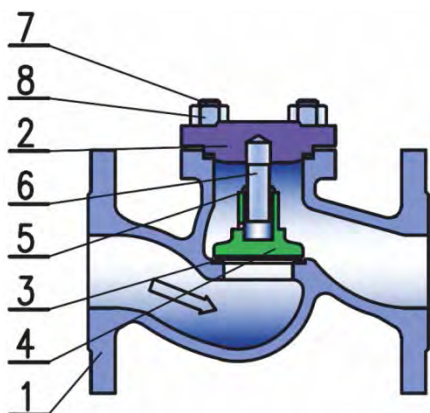

ITEM	NAME	MATERIAL	
1	BODY	GP240GH (1.0619), P250GH (1.0460), GS21Mn5, 422643, 422745,	1.4408, 1.4541, 1.4571, 422931, 422942
2	BONNET		
3	BODY SEAT PLUG SEAT	18-8-Cr Ni 13Cr, 17Cr, Stl.6	
4	PLUG	1.4031, 1.4028, 1.4571, 17242	
5	SLEEVE	1.4031, 1.4028, 1.4571, 17242	
6	PLUG GUIDE		
7	BONNET STUD	8.8	A2-70
8	NUT	8.8	A2-70

DIMENSIONS - DIRECT

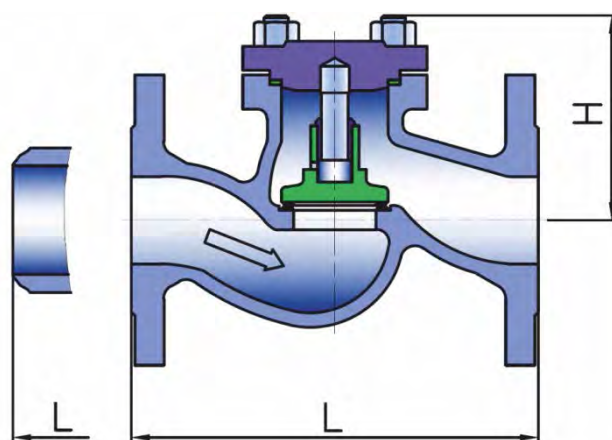

DN	PN 16				PN 40				PN 63				PN 100			
	L		H	Mass (kg)	L		H	Mass (kg)	L		H	Mass (kg)	L		H	Mass (kg)
	1	2			1	2			1	2			1	2		
10	130	130	65	1,8	130	130	66	2,2	210	210	75	2,7	210	210	75	2,7
15	130	130	65	2,2	130	130	66	3	210	210	75	3	210	210	75	3,5
25	160	160	75	3,6	160	160	80	5	230	230	100	5,1	230	230	100	5,2
32	180	180	90	5	180	180	88	7	260	260	110	10,8	260	260	110	11
40	200	200	100	7,5	200	200	105	10	260	260	115	11,8	260	260	115	12
50	230	230	110	9,5	230	230	115	13	300	300	130	14,3	300	300	130	15,5
65	290	290	130	16	290	290	135	21	340	340	150	25	340	340	150	35
80	310	310	140	20	310	310	145	29	380	380	165	33	380	380	165	42
100	350	350	170	31	350	350	175	43	430	430	185	57	430	430	185	65
150	480	480	235	67	480	480	240	98	550	550	260	118	550	550	260	150
200	600	600	280	152	600	600	285	188	650	650	310	220	650	650	310	273
250	730	730	340	180	730	730	350	222	775	775	365	260	775	775	365	312
300	850	850	400	230	850	850	410	280	900	900	430	350	900	900	430	416

LIFT CHECK VALVES

TYPE Z15

DIMENSIONS - ANGLE

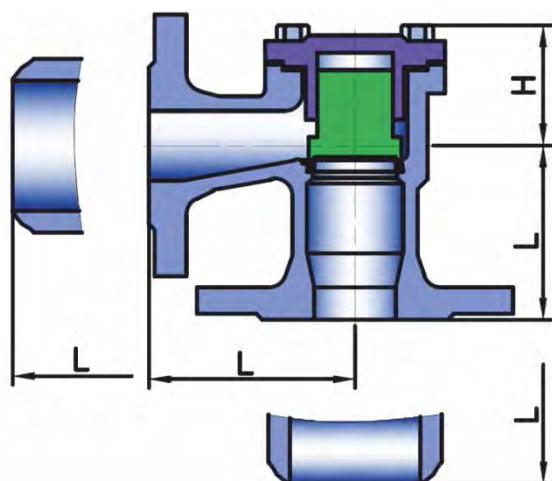

DN	PN 16				PN 40			
	L		H	Mass (kg)	L		H	Mass (kg)
	1	2			1	2		
10	90	90	65	2,5	90	90	66	3,5
15	90	90	65	3,5	90	90	66	4
25	100	100	75	5,5	100	100	80	7
32	105	105	90	8	105	105	90	10
40	115	115	100	11	115	115	100	14
50	125	125	110	14	125	125	110	19
65	145	145	130	23	145	145	130	30
80	155	155	140	30	155	155	140	36
100	175	175	170	47	175	175	170	59
150	225	225	210	96	225	225	240	120
200	275	275	235	190	275	275	260	270
250	---	---	---	---	---	---	---	---
300	---	---	---	---	---	---	---	---

TYPE DESIGNATION

Z15 AC/DE M₁ PN/S

A BODY DESIGN

- 1 Direct
- 2 Angle

C CONNECTION INTO PIPE

- 1 Flanged
- 2 Welded

D FLANGE FACING

FLANGES BY EN 1092 - 1

- A Flat face
- B Raised face
- C Tongue face
- D Groove face
- E Spigot
- F Recess
- G O - ring recess
- H O - ring groove

E CONTROL

- 7 Automatic

M₁ BODY MATERIAL

- 0 Stainless steel
- 2 Cast alloy steel
- 5 Cast Carbon steel
- LT Carbon steel for low temperatures

S SPECIAL EXECUTION

- As Antistatic





Range DN: 10 ~ 300



PED 97/23/EC
PED 2014/68/EU



TR TS 10/11,
12/11, 32/11



Range PN: 16 ~ 100



EN 12 569
CERTIFICATE

Operating temperature: -196 °C ~ 550 °C

Connection into piping: Flanged, welded ends, threaded ends, combined execution

DESCRIPTION

Z16 lift check valves are automatic check valves. They automatically prevent the reverse flow of the medium. The medium can flow in one direction only. These valves are designed and manufactured to ensure maximum service life and reliability.

MATERIAL SPECIFICATION

Z16 lift check valves are made from carbon, alloy and stainless steels. The material type can be adjusted according to the customer's request to optimally suit the operating conditions.

APPLICATION

Z16 lift check valves are suitable for various liquids, gases and steam.

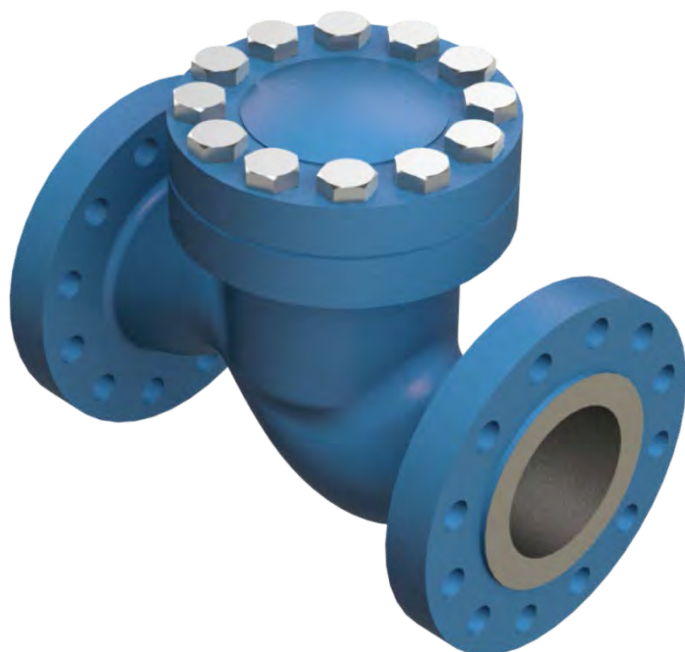

BASIC STANDARDS FOR DESIGN

Basic design

EN 13 709

Pressure-temperature rating

EN 12 516 - 1

Testing

EN 12 266 - 1, 2

Face-to-face dimensions

EN 558, EN 12 982

Dimensions of the welded ends

EN 12 627

Top Flange dimensions

None

Flange dimensions

EN 1092 - 1

Special

NACE MR-0175

LIFT CHECK VALVES

TYPE Z16

MATERIAL SPECIFICATION

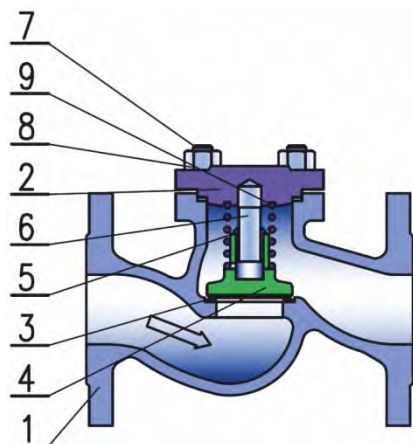

ITEM	NAME	MATERIAL	
1	BODY	GP240GH (1.0619), P250GH (1.0460), GS21Mn5, 422643, 422745	1.4408, 1.4541, 1.4571, 422931, 422942
2	BONNET		
3	BODY SEAT PLUG SEAT	18-8-Cr Ni 13Cr, 17Cr, Stl.6	
4	PLUG	1.4031, 1.4028, 1.4571, 17242	
5	SLEEVE	1.4031, 1.4028, 1.4571, 17242	
6	PLUG GUIDE		
7	BONNET STUD	8.8	A2-70
8	NUT	8.8	A2-70
9	SPRING	1.4301, 17242	

DIMENSIONS - ANGLE

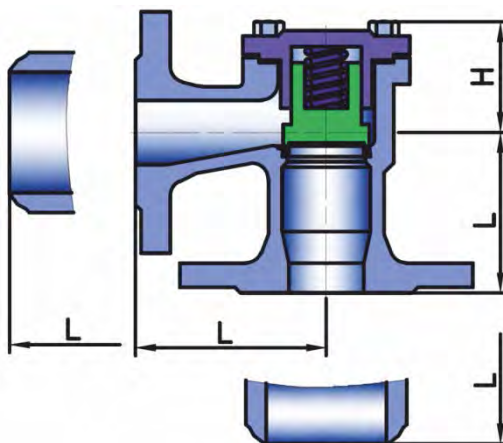

DN	PN 16				PN 40			
	L		H	Mass (kg)	L		H	Mass (kg)
	1	2			1	2		
10	90	90	65	2,5	90	90	66	3,5
15	90	90	65	3,5	90	90	66	4
25	100	100	75	5,5	100	100	80	7
32	105	105	90	8	105	105	88	10
40	115	115	100	11	115	115	80	14
50	125	125	110	14	125	125	90	19
65	145	145	130	23	145	145	110	30
80	155	155	140	30	155	155	125	36
100	175	175	170	47	175	175	145	59
150	225	225	210	96	225	225	240	120
200	275	275	235	190	275	275	260	270
250	---	---	---	---	---	---	---	---
300	---	---	---	---	---	---	---	---

LIFT CHECK VALVES

TYPE Z16

MATERIAL SPECIFICATION

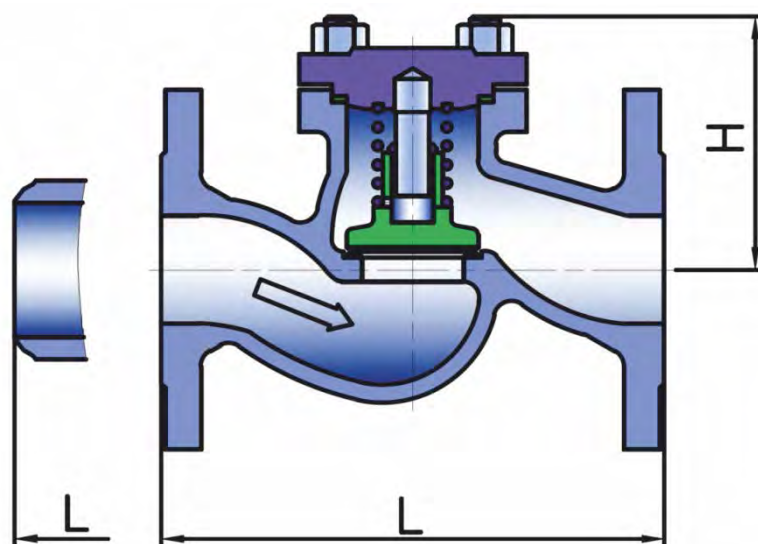

DN	PN 16				PN 40				PN 63				PN 100			
	L		H	Mass (kg)	L		H	Mass (kg)	L		H	Mass (kg)	L		H	Mass (kg)
	1	2			1	2			1	2			1	2		
10	130	130	65	1,8	130	130	66	2,2	210	210	75	2,7	210	210	75	2,7
15	130	130	65	2,2	130	130	66	3	210	210	75	3	210	210	75	3,5
25	160	160	75	3,6	160	160	80	5	230	230	100	5,1	230	230	100	5,2
32	180	180	90	5	180	180	88	7	260	260	110	10,8	260	260	110	11
40	200	200	100	7,5	200	200	105	10	260	260	115	11,8	260	260	115	12
50	230	230	110	9,5	230	230	115	13	300	300	130	14,3	300	300	130	15,5
65	290	290	130	16	290	290	135	21	340	340	150	25	340	340	150	35
80	310	310	140	20	310	310	145	29	380	380	165	33	380	380	165	42
100	350	350	170	31	350	350	175	43	430	430	185	57	430	430	185	65
150	480	480	235	67	480	480	240	98	550	550	260	118	550	550	260	150
200	600	600	280	152	600	600	285	188	650	650	310	220	650	650	310	273
250	730	730	340	180	730	730	350	222	775	775	365	260	775	775	365	312
300	850	850	400	230	850	850	410	280	900	900	430	350	900	900	430	416

LIFT CHECK VALVES

TYPE Z16

TYPE DESIGNATION

Z16 AC/DE M₁ PN/S
A BODY DESIGN

- 1 Direct
- 2 Angle

C CONNECTION INTO PIPE

- 1 Flanged
- 2 Welded

D FLANGE FACING
FLANGES BY EN 1092 - 1

- A Flat face
- B Raised face
- C Tongue face
- D Groove face
- E Spigot
- F Recess
- G O - ring recess
- H O - ring groove

E CONTROL

- 7 Automatic

M₁ BODY MATERIAL

- 0 Stainless steel
- 2 Cast alloy steel
- 5 Cast Carbon steel
- LT Carbon steel for low temperatures

S SPECIAL EXECUTION

- As Antistatic

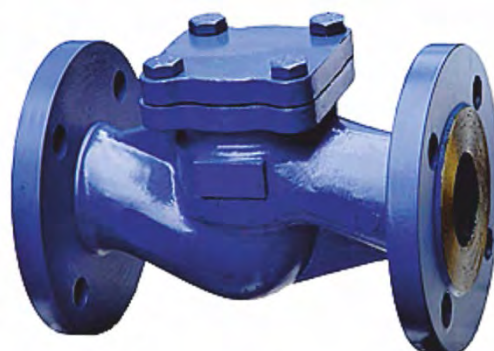



Range DN: 15 ~ 600
NPS: 1/2" ~ 24"



Range PN: 16 ~ 400
Class: 150 ~ 2500



PED 97/23/EC
PED 2014/68/EU



TR TS 10/11,
12/11, 32/11



EN 12 569
CERTIFICATE

Operating temperature: - 196 °C ~ + 550 °C

Connection into piping: Flanged, threaded ends, welded ends, combined execution



DESCRIPTION

STR Y-shaped strainers are automatic valves designed to protect suction pipes from infiltration by impurities. The medium can flow in one direction only. These filters are designed and manufactured to ensure maximum service life and reliability. **Options such as T - shape or suction strainer execution can be produced on the customer's request.**

MATERIAL SPECIFICATION

STR Y-shaped and T-shaped strainers are made from carbon, alloy and stainless steels. The material type can be adjusted according to the customer's request to optimally suit the operating conditions.

APPLICATION

STR Y-shaped and T-shaped strainers are suitable for various liquids, gases and steam.

BASIC STANDARDS FOR DESIGN

Basic design

EN 12 516 - 1, ANSI B16.34

Face-to-face dimensions

EN 558, EN 12 982, ANSI B16.10

Flange dimensions

EN 1092 - 1, EN 1759 - 1

Pressure-temperature rating

EN 12 516 - 1, ANSI B16.34

Dimensions of the welded ends

EN 12 627, ANSI B16.25

Special

NACE MR-0175

Testing

EN 12 266 - 1, 2

Top Flange dimensions

None

STRAINERS

TYPE STR

MATERIAL SPECIFICATION - CASTING

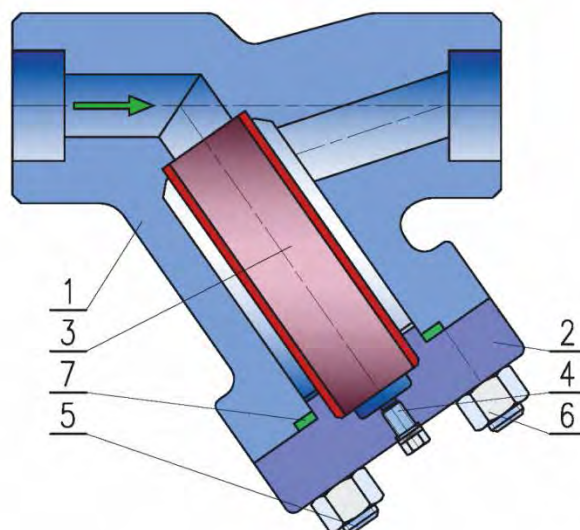
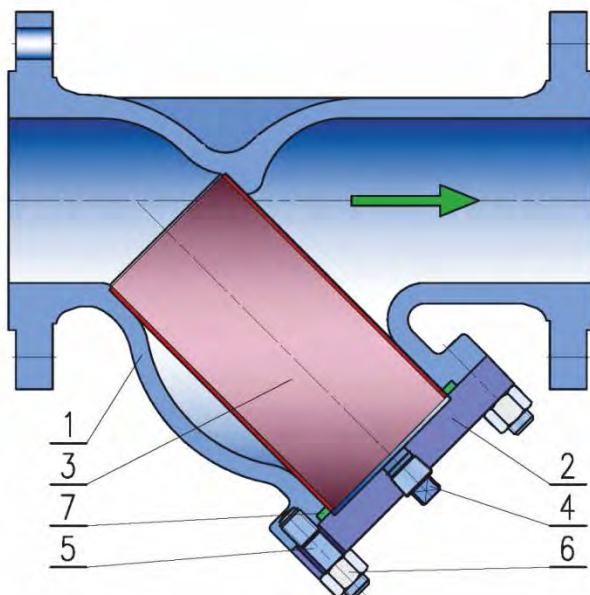

ITEM	NAME	A105	WCB	LCC	LCB	WC6	WC9	C5	C12	CF8 / 304	CF8M / 316
1	BODY	A105	A216 WCB	A352 LCC	A352 LCB	A217 WC6	A217 WC9	A217 C5	A217 C12	A351 CF8	A351 CF8M
2	BONNET	A105	A105	A352 LCC	A352 LCB	A217 WC6	A217 WC9	A217 C5	A217 C12	SS 316	SS 316
3	STRAINER	SS304	SS304	SS304	SS304	SS304	SS304	SS304	SS304	SS 316	SS 316
4	PLUG	A105	A 105	A 105	A 105	A182 F5 + surfacing	A182 F5 + surfacing	A182 F5 + surfacing	A182 F5 + surfacing	A351 CF8 + surfacing	A351 CF8M + surfacing
5	BOLT	A193 B7	A193 B7	A320 L7	A320 L7	A193 B16	A193 B16	A193 B16	A193 B16	A193 B8	A193 B8M
6	NUT	A194 2H	A194 2H	A194 4	A194 4	A194 2H	A194 2H	A194 2H	A194 2H	A194 8	A194 8M
7	SEALING	SS316 + graphite									

STRAINERS

TYPE STR

DIMENSIONS - CASTING

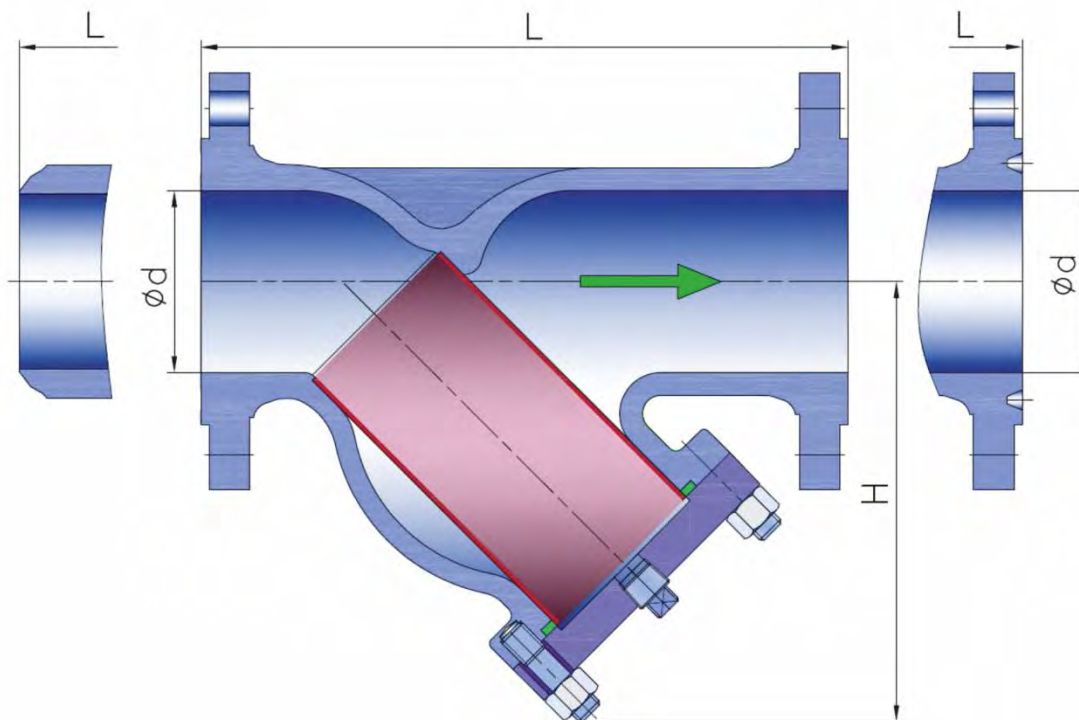

DN	PN 16						PN 25						PN 40						PN 63						PN 100					
	L		H	MASS (KG)		L		H	MASS (KG)		L		H	MASS (KG)		L		H	MASS (KG)		L		H	MASS (KG)						
	1	2		1	2	1	2		1	2	1	2		1	2	1	2		1	2	1	2		1	2					
15	130	130	70	3	2	130	130	70	3	2	130	130	70	3	2	216	216	130	5	3	210	210	130	5	3					
20	150	150	75	4	2	150	150	75	4	3	150	150	75	4	3	229	229	130	9	5	220	220	130	10	5					
25	160	160	80	5	3	160	160	80	5	3	160	160	80	5	3	254	254	140	11	6	230	230	140	11	6					
32	180	180	90	7	4	180	180	90	8	5	180	180	90	8	5	279	279	160	13	8	250	250	160	14	9					
40	200	200	100	9	5	200	200	100	10	6	200	200	100	10	6	270	270	190	17	10	260	260	190	17	10					
50	230	230	115	13	7	230	230	115	13	8	230	230	115	13	8	300	300	205	21	11	300	300	205	24	14					
65	290	290	130	16	10	290	290	130	18	12	290	290	130	19	12	340	340	230	25	16	340	340	230	33	20					
80	310	310	145	21	14	310	310	145	23	16	310	310	145	24	16	380	380	240	31	20	380	380	240	40	25					
100	350	350	170	29	20	350	350	170	32	23	350	350	170	36	24	430	430	270	46	30	430	430	270	59	38					
125	400	400	220	42	31	400	400	220	47	36	400	400	220	53	36	500	500	335	72	49	500	500	335	96	61					
150	480	480	280	60	46	480	480	290	68	53	480	480	290	75	54	550	550	375	108	75	550	550	375	136	88					
200	600	600	340	117	98	600	600	370	128	99	600	600	370	146	111	-	-	-	-	-	-	-	-	-	-					
250	730	730	390	182	154	730	730	420	211	171	730	730	420	250	191	-	-	-	-	-	-	-	-	-	-					
300	850	850	500	281	243	850	850	530	321	268	850	850	530	386	296	-	-	-	-	-	-	-	-	-	-					
350	980	980	620	424	368	980	980	650	494	410	980	980	650	586	453	-	-	-	-	-	-	-	-	-	-					
400	1100	1100	700	598	526	1100	1100	730	698	582	1100	1100	730	849	655	-	-	-	-	-	-	-	-	-	-					
500	1250	1250	900	1007	914	1250	1250	940	1153	1013	1250	1250	940	1417	1109	-	-	-	-	-	-	-	-	-	-					

STRAINERS

TYPE STR

DIMENSIONS - CASTING

		CLASS 150					CLASS 300					CLASS 600					CLASS 900					CLASS 1500				
NPS	DN	L		H	MASS (KG)		L		H	MASS (KG)		L		H	MASS (KG)		L		H	MASS (KG)		L		H	MASS (KG)	
		1	2		1	2	1	2		1	2	1	2		1	2	1	2		1	2	1	2		1	2
1/2	15	146	146	120	2	1	152	152	120	3	2	165	165	120	5	4	165	-	60	9	-	216	-	75	9	-
3/4	20	172	172	140	3	2	178	178	140	5	3	191	191	140	7	4	191	-	75	11	-	229	-	93	11	-
1	25	197	197	170	4	2	203	203	170	6	3	216	216	170	12	9	216	-	93	16	-	254	-	144	16	-
1 1/2	40	219	219	180	7	4	229	229	180	11	6	241	241	180	19	13	241	-	144	26	-	305	-	140	26	-
2	50	203	203	140	12	8	267	267	175	15	9	292	292	193	35	28	368	368	250	50	30	368	368	250	52	32
3	80	241	241	210	21	13	318	318	240	35	23	356	356	260	48	34	381	381	295	61	38	470	470	325	76	39
4	100	292	292	270	32	20	356	356	330	51	32	435	435	310	90	61	457	457	375	104	65	546	546	375	128	71
6	150	406	406	360	48	31	445	445	380	92	61	559	559	400	220	162	610	610	555	269	187	705	705	480	324	198
8	200	495	495	460	105	79	559	559	500	182	134	660	660	500	360	273	737	737	665	425	284	832	832	620	499	290
10	250	622	622	570	169	132	622	622	538	285	217	787	787	600	500	359	838	838	650	595	394	-	-	-	-	-
12	300	698	698	700	215	155	711	711	699	387	287	838	838	720	742	574	965	965	650	859	593	-	-	-	-	-
14	350	788	788	770	364	289	838	838	805	519	380	892	892	865	905	707	-	-	-	-	-	-	-	-	-	-
16	400	914	914	870	525	424	864	864	920	676	499	994	994	1180	1186	902	-	-	-	-	-	-	-	-	-	-
18	450	978	978	975	681	563	978	978	1025	897	680	-	-	-	-	-	-	-	-	-	-	-	-	-	-	-
20	500	978	978	1095	846	700	1016	1016	1140	1128	859	-	-	-	-	-	-	-	-	-	-	-	-	-	-	-
24	600	1295	1295	1300	1409	1216	1346	1346	1360	1625	1223	-	-	-	-	-	-	-	-	-	-	-	-	-	-	-

DIMENSIONS - FORGING

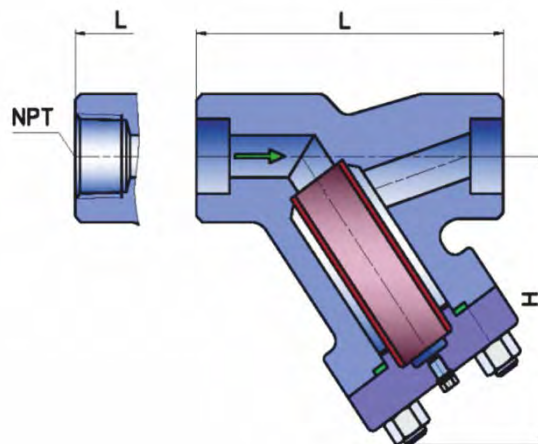

		CLASS 800				CLASS 1500				CLASS 2500			
NPS	DN	NPT	L	H	MAS S (KG)	NPT	L	H	MAS S (KG)	NPT	L	H	MAS S (KG)
1/2	15	1/2	90	60	1	1/2	110	75	1,4	1/2	190	160	2
3/4	20	3/4	110	75	1,2	3/4	130	93	2,2	3/4	190	160	3,2
1	25	1	130	93	2	1	180	144	6,2	1	190	160	8
1 1/2	40	1 1/2	180	144	6	1 1/2	185	140	7,5	1 1/2	190	170	12
2	50	2	185	140	7	-	-	-	-	2	213	190	148

STRAINERS

TYPE STR

MATERIAL SPECIFICATION - TUBULAR

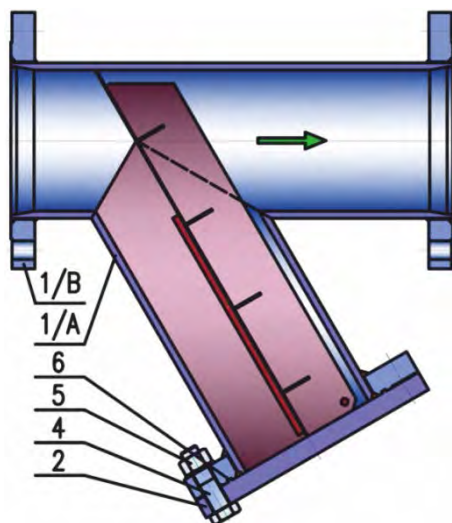

ITEM	NAME	MATERIAL	
1 / A	BODY (TUBES)	1.4301 (304), 1.4306 (304L), 1.4401 (316), 1.4404 (316L), 1.4541	P215 NL, P235 GH, P265 GH, P355 NL1 A106 Gr.B
1 / B	BODY (FLANGES)	1.4301 (304), 1.4306 (304L), 1.4401 (316), 1.4404 (316L), 1.4541	P265 GH, P355 NH, P355 NL1 A350 LF2, A105
2	BONNET	1.4301 (304), 1.4306 (304L), 1.4401 (316), 1.4404 (316L), 1.4541	P265 GH, P355 NH, P355 NL1 A350 LF2, A105
3	STRAINER	1.4301 (304), 1.4401 (316), 1.4404 (316L), 1.4541	
4	BOLT	A2-70	8.8 , 25CrMo4
5	NUT	A2-70	8 , A2-70
6	SEALING	Graphite, Graphite+304, Graphite+316	

DIMENSIONS - TUBULAR

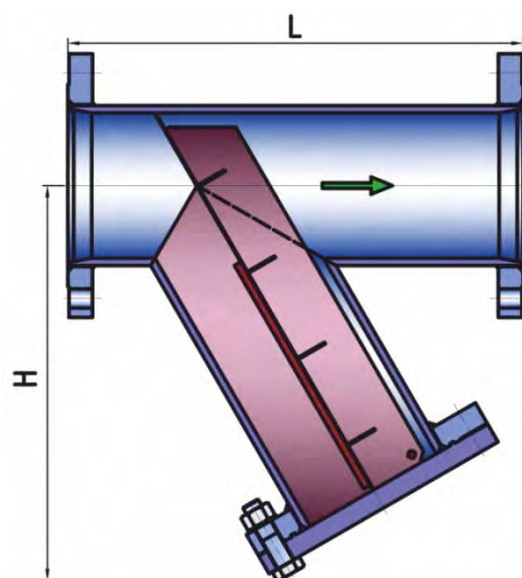

DN	PN 40						PN 63						PN 100					
	L		H	MASS (KG)		L		H	MASS (KG)		L		H	MASS (KG)				
	1	2		1	2	1	2		1	2	1	2						
25	230	216	148	7	5	230	216	161	14	9	230	216	161	14	9			
32	260	229	173	11	7	260	229	184	16	10	260	229	184	16	10			
40	260	241	184	13	9	260	241	198	22	13	260	241	198	22	13			
50	300	292	224	15	9	300	292	235	23	13	300	292	243	28	16			
65	340	330	257	21	13	340	330	268	30	17	340	330	277	38	22			
80	380	356	303	34	20	380	356	306	36	22	380	356	316	46	27			
100	430	432	342	39	26	430	432	353	52	33	430	432	364	66	41			
125	500	508	398	58	40	500	508	413	81	53	500	508	424	108	67			
150	550	559	468	79	56	550	559	488	119	79	550	559	498	155	97			
200	650	660	600	161	120	650	660	617	222	151	650	660	629	287	186			
250	775	787	674	271	205	775	787	688	338	240	775	787	710	473	313			
300	900	838	782	409	314	900	838	794	492	357	900	838	824	729	483			
350	1025	889	843	564	424	1025	889	858	703	495	1025	889	891	1016	661			
400	1150	991	954	740	540	1150	991	966	890	618	-	-	-	-	-			

STRAINERS

TYPE STR

TYPE DESIGNATION

STR A C/D E M₁ PN or Class/S
A BODY DESIGN

- T T-shape
- Y Y-shape
- SAK suction strainer

E CONTROL

- 9 Without control

C CONNECTION INTO PIPE

- 1 Flanged
- 2 Welded
- 3 Threaded
- 8 Combined

M₁ BODY MATERIAL

- 0 Stainless steel
- 2 Cast alloy steel

E FLANGE FACING
EN 1092 - 1

- A Flat face
- B Raised face
- C Tongue face
- D Groove face
- E Spigot
- F Recess
- G O - ring recess
- H O - ring groove

EN 1759 - 1

- PFF Flat sealing face
- RF Raised face
- LTF Large tongue
- STF Small tongue
- LGF Large groove
- SGF Small groove
- LMF Large male
- SMF Small male
- LFF Large female
- SFF Small female
- RTJ Ring joint

- 3 Forged alloy steel

- 4 Forged carbon steel

- 5 Cast carbon steel

- LT Carbon steel for low temperatures

